

IMECE2005-79316

INFLUENCE OF STEAM INJECTION ON THERMAL EFFICIENCY AND OPERATING TEMPERATURE OF GE-F5 GAS TURBINES APPLYING VODOLEY SYSTEM

Mohsen Ghazikhani

Department of Mechanical
Engineering
Mashad University, Mashad, IRAN
ghazikhani@ferdowsi.um.ac.ir

Nima Manshoori

Faculty of Mechanical Engineering
IRAN University of Science and
Technology, Tehran, IRAN
nmanshoori@mecheng.iust.ac.ir

Davood Tafazoli

Faculty of Mechanical Engineering
Shiraz University, Shiraz,
IRAN
dtafazoli@shirazu.ac.ir

ABSTRACT

An industrial gas turbine has the characteristic that turbine output decreases on hot summer days when electricity demand peaks. For GE-F5 gas turbines of Mashad Power Plant when ambient temperature increases 1°C , compressor outlet temperature increases 1.13°C and turbine exhaust temperature increases 2.5°C . Also air mass flow rate decreases about 0.6 kg/sec when ambient temperature increases 1°C , so it is revealed that variations are more due to decreasing in the efficiency of compressor and less due to reduction in mass flow rate of air as ambient temperature increases in constant power output. The cycle efficiency of these GE-F5 gas turbines reduces 3 percent with increasing 50°C of ambient temperature, also the fuel consumption increases as ambient temperature increases for constant turbine work. These are also because of reducing in the compressor efficiency in high temperature ambient. Steam injection in gas turbines is a way to prevent a loss in performance of gas turbines caused by high ambient temperature and has been used for many years. VODOLEY system is a steam injection system, which is known as a self-sufficient one in steam production. The amount of water vapor in combustion products will become regenerated in a contact condenser and after passing through a heat recovery boiler is injected in the transition piece after combustion chamber. In this paper the influence of steam injection in Mashad Power Plant GE-F5 gas turbine parameters, applying VODOLEY system, is being observed. Results show that in this turbine, the turbine inlet temperature (T_3) decreases in a range of 5 percent to 11 percent depending on ambient temperature, so the operating parameters in a gas turbine cycle equipped with VODOLEY system in 40°C of

ambient temperature is the same as simple gas turbine cycle in 10°C of ambient temperature. Results show that the thermal efficiency increases up to 10 percent, but Back-Work ratio increases in a range of 15 percent to 30 percent. Also results show that although VODOLEY system has water treatment cost but by using this system the running cost will reduce up to 27 percent.

INTRODUCTION

Gas turbine output is a strong function of ambient air temperature [1]. One way to prevent the loss in performance of gas turbine caused by high ambient temperature is to cool the inlet air of gas turbine compressor [2, 3]. There are several methods to cool the air at the compressor inlet such as Media Based Evaporative Cooling, Mechanical Chilling and Thermal Energy Storage system [4, 5]. But these various inlet cooling techniques available today have certain limitations such as operating cost, ambient condition dependency and low efficiency.

Steam injection in gas turbines has been used for many years to increase both the power output and efficiency of gas turbines. [6, 7, 8, 9, 10]

VODOLEY system is a steam injection system, which is known as a self-sufficient one in steam production. The amount of water vapor in combustion products will become regenerated in a contact condenser and after passing through a heat recovery boiler is injected in the transition piece after combustion chamber. In VODOLEY system the net power output increases because the steam injected in transition piece after combustion chamber increases the mass flow rate through the turbine without adding fuel consumption or

adding the air mass flow through the compressor. A major disadvantage of steam-injected gas turbine is the large water consumption. But placing a condenser in VODOLEY system makes it possible to recover all the injected steam.

Rice[6], Larson and Williams[7], De Paepe and Dick[8], have studied the thermodynamic performance of steam injected cycles.

In present work the influence of steam injection in Mashad Power Plant GE-F5 gas turbine parameters, applying VODOLEY system, is being observed by developing computer code, which is based on experimental data of various components of this cycle.

NOMENCLATURE

P	Pressure
T	Temperature
H	Enthalpy
Q	Heat Energy
r_p	Compressor Pressure Ratio
S	Entropy
\dot{m}	Mass Flow Rate
η	Efficiency

Subscripts

1	Compressor Inlet
2	Compressor Discharge
3	Turbine Inlet
4	Turbine Discharge
a	After Steam Injection
b	Before Steam Injection
f	Fuel
p	Pump
s	Isentropic
St	Steam
w	Water
Comp	Compressor
Tur	Turbine
Comb	Combustion
LHV	Low Heat Value

SYSTEM DESCRIPTION:

A Schematic diagram of VODOLEY system is shown in Figure 1. In Gas turbine, unit (1), while operating under VODOLEY cycle, the exhaust flow after passing through the waste heat recovery boiler (2) is discharged into water-steam contact condenser (3). Contact condenser is able to extract water from exhaust gas and recycle it through the system. It is installed on discharge flange of waste heat recovery boiler. Cooling water cools down the exhaust gas below dew point temperature condenses the water and passes it through a cleaning block (5) and then collects it in the reservoir tank (6). Two pumps (8) have been used to pump the water to contact condenser and boiler. Water returns to feed water tank (6), is chemically treated and recycled.

As it is mentioned above in Figure 1, wet condenser is shown schematically by No. (3), its position is after the steam generator. The exhaust energy is decreased in the steam generator. Combustion products then arrive to the wet

condenser. In the wet condenser injecting cooling water reduces the combustion products (exhaust) temperature. Cooling water increases the mole fraction of water. This means that there is a dew point in the wet condenser. However a special mechanism exists in the wet condenser that reduces the exhaust motion to make the flow possible to be condensed. Always there is some water that passes the wet condenser. But it should be considered that the water injection makes the possibility to collect more water from the exhaust gas flow.

SYSTEM IMPLEMENTATION:

STEAM INJECTION APPLICATION ON FRAME 5 GAS TURBINE

For the purpose of investigating the results of steam injection on gas turbine parameters, a steam injection system is applied on the GE-F5 gas turbine of Mashad Power Plant. The steam is supplied from the Boiler of 60 MW SKODA Steam Turbine Power Plant in 350°C temperature and 20 bar pressure, as shown in Figure 2.

ASSUMPTIONS FOR THERMODYNAMIC CONSIDERATION

- Working fluid is assumed to be Air as an ideal gas with variable specific heats.
- Low heat Value of Fuel equals to 49884 kJ/kg according to Mashad natural gas chemical analysis.
- The Injected Steam is in 350° C temperature and 20-bar pressure
- Compression and expansion processes in compressor and turbine are assumed to be isentropic.
- Combustion chamber pressure loss is negligible.
- According to diluted air-fuel mixture in gas turbines, the molecular mass of exhaust flow is assumed to be equal to air.
- The average turbine exhaust flow temperature is assumed to be 500°C, for maximum output of gas turbine [11] , [13].
- The maximum output power of GE-F5 gas turbine with VODOLEY system is assumed to be 25MW.
- Combustion efficiency is computed and can be assumed to be equal to % 98.5 (Fig. 6). [11], [12],[13].

VODOLEY SYSTEM THERMODYNAMIC CONSIDERATION:

For computing compressor outlet pressure and temperature, based on the experimental tests and measurements, an ideal polytropic process has been assumed before and after steam injection. Compressor outlet temperature and pressure (T_{2a} , P_{2a}) after steam injection are obtained from the Eqs. (1) And (5), [13]:

$$T_{2a} = T_{2b} \left(\frac{P_{2a}}{P_{2b}} \right)^{\frac{\gamma_c - 1}{\gamma_c}} \quad (1)$$

Where T_{2a} is the compressor outlet temperature after steam injection and T_{2b} is the compressor outlet temperature before steam injection. Also P_{2a} is compressor outlet pressure after

steam injection and T_{2b} is the compressor outlet pressure before steam injection. γ_c is the specific heat ratio across the compressor respectively which is determined as follows:

$$\gamma_c = \frac{c_p}{c_v} \quad (2)$$

Where c_p and c_v are the specific heats of air at constant pressure and at constant volume respectively, both in kJ/kg. K and they are evaluated at the average temperature across the compressor from the following relations [14]:

$$cp_{air} = \frac{8.314}{2897} (3.653 - 1.337 \times 10^{-3} T_{av} + 3.294 \times 10^{-6} T_{av}^2 - 1.913 \times 10^{-9} T_{av}^3 + 2.763 \times 10^{-13} T_{av}^4) \quad (3)$$

$$cv_{air} = cp_{air} - 0.287 \quad (4)$$

Compression pressure can be assumed as a function of energy released in combustion chamber. Equation (5) shows the relation between compression pressure and released energy in combustion chamber [13].

Energy released in combustion chamber has two sources: first the energy from combustion process and second the energy from injected steam. Figure 3 shows the compression pressure versus released energy. For simple GE-F5 gas turbine, P_{2b} have been measured and presented in the Figure 3 versus energy released in combustion chamber [13].

$$P_{2a} = f(\dot{m}_f Q_{LHV} + \dot{m}_{St} h_{St}) \quad (5)$$

In Figure 3, $(P_2)_1$, $(P_2)_2$ and $(P_2)_3$ are the compressor discharge pressures when the output powers are 10 MW, 15 MW and 20 MW respectively. $(P_2)_4$ is the compressor discharge pressure in VODOLEY cycle when the output power is 25 MW.

So, according to that figure, compression pressure variations after steam injection (P_{2a}) can be obtained by average trends as shown in figure 3.

According to control volume illustrated in figure 4:

$$h_4 = \frac{\dot{m}_{air} h_1 + \dot{m}_f \eta_{comb} Q_{LHV} + \dot{m}_{St} h_{St} - \dot{W}_{Cycle}}{\dot{m}_{air} + \dot{m}_f + \dot{m}_{St}} \quad (6)$$

Since T_4 is a measured parameter, therefore h_4 is obtained from the air standard schedule, except \dot{m}_f and \dot{m}_s , other parameters are known either from assumptions or experimental data. \dot{m}_f and \dot{m}_s can be obtained by solving Eq.(5) and Eq.(6) simultaneously.

According to control volume illustrated in Figure 5 the enthalpy of combustion products entering to turbine is computed as follows:

$$h_3 = h_4 + \frac{\dot{m}_{air} (h_2 - h_1) + \dot{W}_{Cycle}}{\dot{m}_{air} + \dot{m}_f + \dot{m}_{St}} \quad (7)$$

So the turbine inlet temperature can be obtained from the air standard schedule.

Isentropic efficiencies of compressor and turbine are computed as follows:

$$\eta_{Comp} = \frac{h_{2s} - h_1}{h_2 - h_1} \quad (8)$$

$$\eta_{tur} = \frac{h_3 - h_4}{h_3 - h_{4s}} \quad (9)$$

Where h_{2s} and h_{4s} are isentropic enthalpy of compressor and turbine discharged flow respectively and can be obtained as follows [13]:

$$S_2 - S_1 = (\dot{S}_{T_2} - \dot{S}_{T_1}) - RLn \frac{P_2}{P_1} = 0 \quad (10)$$

$$S_4 - S_3 = (\dot{S}_{T_4} - \dot{S}_{T_3}) - RLn \frac{P_4}{P_3} = 0 \quad (11)$$

\dot{S}_{T_2} and \dot{S}_{T_4} can be obtained from Eqs. (10) and (11), then h_{2s} and h_{4s} can be obtained from air standard schedule by \dot{S}_{T_2} and \dot{S}_{T_4} . Equation (12) is used to compute the power consumption of recycling pumps [13]:

$$\dot{W}_p = \dot{m}_w \int_{P_1}^{P_2} v dp \quad (12)$$

In the above equation P_1 is the ambient pressure and is about 92 (kPa), P_2 is the injected steam pressure and should be 2000 (kPa). So \dot{W}_p will be about 278 kW for each pump.

The cycle efficiency is the ratio of power output to energy consumed; VODOLEY cycle efficiency is obtained by the following equation:

$$\eta_{Cycle} = \frac{\dot{W}_{Cycle}}{\dot{m}_f Q_{LHV} \eta_{Comb} + \dot{W}_p} \quad (13)$$

And finally Back-Work ratio obtains from the Eq. (9):

$$B.W = \frac{\dot{m}_{air} (h_2 - h_1)}{(\dot{m}_{air} + \dot{m}_f + \dot{m}_{St})(h_3 - h_4)} \quad (14)$$

EXPERIMENTAL DATA:

A computer code is currently used to compute the parameters have mentioned above. Different parameters of gas turbine without steam injection were measured by Fluid Mechanic team of steam injection project on the February 9 of 2003 and have brought in Table No.1.

Also parameters in different ambient temperatures, which are used in computer code, are obtained from daily lock sheets of

PG 5251 GE-F5 gas turbine of Mashad Power Plant. These Lock sheets are exists for different ambient temperatures.

RESULTS AND DISCUSSION

Results are shown in Figures 7 to 16. Figure 7 shows variations of injected steam and fuel mass flow rate versus ambient temperature. Assuming $T_4=500^\circ\text{C}$, $P_2=900$ kPa and $W_{\text{out}}=25$ MW, mass flow rate of injected steam varies from 13.9 kg/sec in -15°C to 6.89 kg/sec in 40°C . Since thermal efficiency reduces as ambient temperature increases (Figure 11), fuel mass flow rate will increase to compromise the constant power output. So, due to limitations of maximum P_2 , when the fuel flow rate increases, the amount of injected steam will decrease.

Figure 8 shows the variation of compressor discharge pressure versus ambient temperature both in without steam injection and VODOLEY system. The most important disadvantage of VODOLEY system is the increment in compressor discharge pressure so compressor discharge temperature will also increase which has shown in Figure 9. Because of the metallurgical limitations for gas turbine blades the decrement in turbine inlet temperature in constant output power is one of the important advantages of VODOLEY system which has shown in Figure 10. Variation of thermal efficiency of gas turbine cycle equipped with VODOLEY system versus ambient temperature has illustrated in Figure 11. As it is clear from the Figure 11, the gas turbine efficiency applying VODOLEY system is about 12 percent higher compared with simple gas turbine cycle and decreases about 4 percent when ambient temperature increases from -15°C to 40°C .

Figure 12 shows that there are no sensible changes in turbine isentropic efficiency when VODOLEY system is applied. Also as shown in Figures 13, the isentropic efficiency of compressor in VODOLEY system is more than the one in simple gas turbine cycle.

The VODOLEY system is a regenerative steam injected cycle which part of the fuel energy is recovered by the injected steam in the waste heat recovery boiler and recycled in the system. That's why the fuel mass flow rate decreases in VODOLEY system, as it is shown in Figure 14.

Since compressor discharge pressure and temperature increases in VODOLEY system then the Back Work ratio is more than the one in simple gas turbine cycle. This has shown in Figure 15.

Turbine exhaust temperature in VODOLEY system is become compared with the same one of simple gas turbine cycle in Figure 16. Figure 16 also implies that simple gas turbine cycle of GE-F5 gas turbine can produce 25 MW output power only if the ambient temperature be less than 10°C . When ambient temperature increases and becomes more than 10°C , turbine exhaust temperature exceeds of its allowable limit. But using VODOLEY system, GE-F5 gas turbine will be able to produce 25 MW power in ambient temperatures up to 40°C .

As it has mentioned before The VODOLEY system is independent from water consumption. It provides the water by itself. The energy costs for water treatment comprise from the power input of two pumps. Two Pumps (No.8) consume about 500kW. Assuming the energy costs to be 8 cent/kWh in Iran,

the maximum cost of water treatment would be 500 kW that means \$40 per hour. Since VODOLEY system has a chemical water treatment block (No.5 in Figure 1) there is no need to provide additional water treatment plants such as R.O plants, but the cost of chemicals which are used in cleaning block is about 6000 \$/Year.

Table 2 shows a comparison between GE-F5 simple cycle and the one equipped with VODOLEY system, it shows that although VODOLEY system has water treatment cost but by using this system total cost will reduce up to 27 percent. It should be notified that the initial investment of the VODOLEY system has not been considered in Table 2.

The initial investment of applying VODOLEY system on GE-F5 gas turbine of Mashad power plant has cost about 2.7 million dollars. So even regarding the initial investment of VODOLEY system installation, it is clear that VODOLEY system is beneficial and will return the initial investment in less than one year.

According to this research another technical paper is going to be established about the wet condenser operation and calculation. Authors would establish it in the near future.

CONCLUSION

1-Compared with GE-F5 simple cycle, GE-F5 cycle equipped with VODOLEY system has less turbine inlet temperature (T_3) in constant power output.

2-Simple GE-F5 cycle can produce 25 MW output power only if the ambient temperature be less than 10°C .

3- GE-F5 gas turbine equipped with VODOLEY system produces 25 MW output power in ambient temperature up to 40°C .

4- In VODOLEY system the Back Work ratio is more than the one in simple gas turbine cycle.

5-Since fuel consumption increases in high ambient temperatures in constant power output; steam mass flow rate should be decreased.

6-VODOLEY systems have water treatment cost. But in compare to simple GE-F5 power station the running cost in VODOLEY system is lower than the one in simple GE-F5 power station, up to 27 percent.

Item No	Power MW	T_1 K	P_1 bar	r_p	T_2 K	P_2 bar	T_4 K	m_a kg/s	m_f kg/s	Speed rpm
1	0	277	0.9012	7.66	520	6.91	446	107.96	0.46	5100
2	5	277	0.9007	8.31	530	7.49	531	102.16	0.66	5100
3	10	277	0.9001	8.78	539	7.91	599	100.4	0.9	5100
4	15	277	0.9006	9.33	548	8.41	667	102.18	1.18	5100
5	19	277	0.899	9.68	554	8.71	728	101.4	1.4	5100

Table 1- Measured Data of Simple GE-F5 Gas Turbine

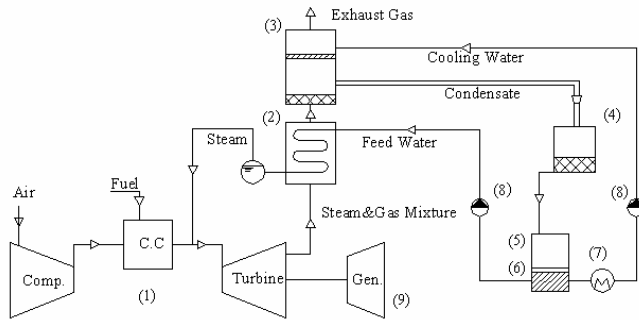

Figure 1. Schematic Diagram of VODOLEY system 1-Gas Turbine Unit 2-Waste-Heat Recovery Boiler 3-Water-Steam Contact Condenser 4-Condensate Collector 5-Condensate Cleaning Block 6- Feed Water Tank 7-External Cooler 8-Pump 9-Turbo Charger

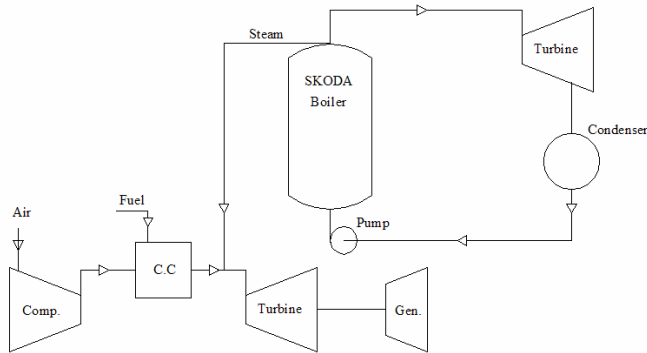

Figure 2. Experimental Setup for Mashad Power Plant GE-F5 Gas Turbine

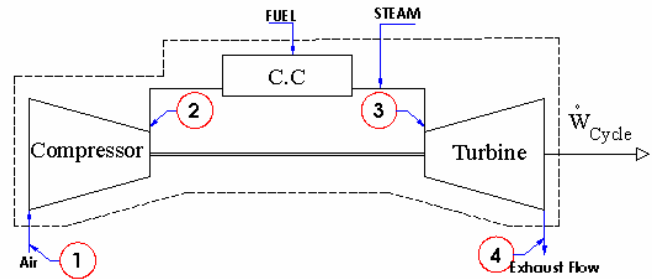

Figure 4. Control Volume for Computing Turbine Exhaust Temperature After Steam Injection

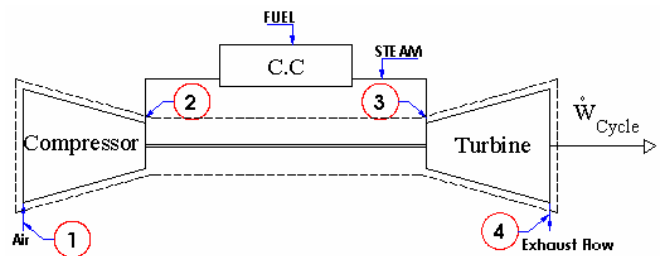

Figure 5. Control Volume for Computing Turbine Inlet Temperature after Steam Injection

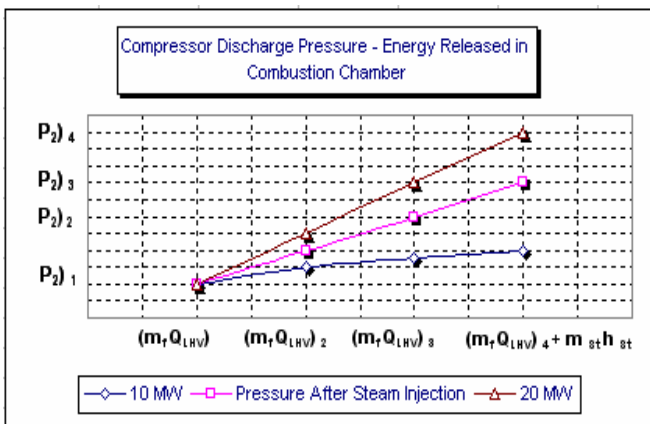

Figure 3. Variations of Compressor Discharge Pressure versus Energy Released in Combustion Chamber for GE-F5 Gas Turbine when $W_{out}=25MW$

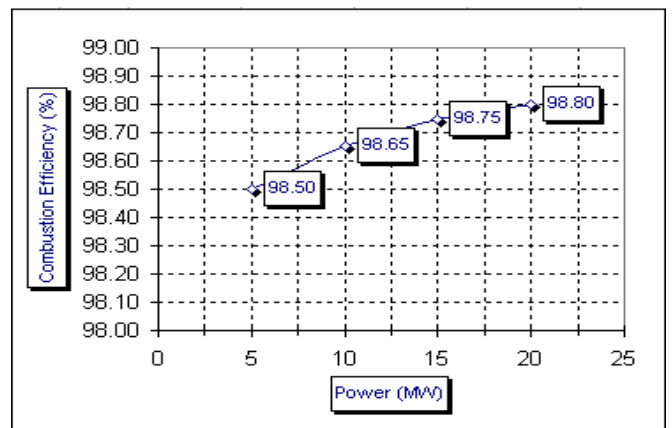

Figure 6. Variations of Combustion Efficiency versus Power Output for GE-F5 Gas Turbine

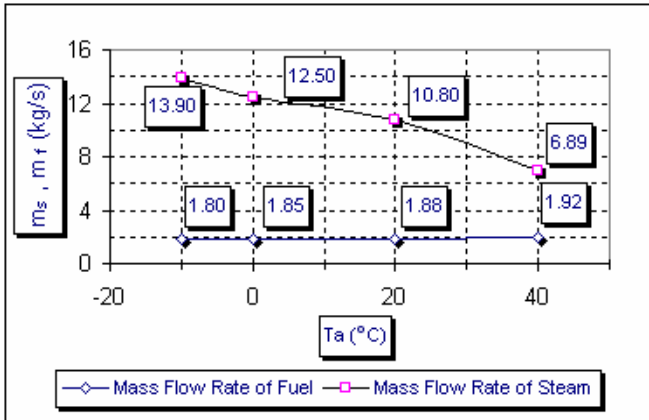

Figure 7. Variations of Fuel and Steam Consumption versus Ambient Temperature For GE-F5 Gas Turbine When $W_{out}=25MW$

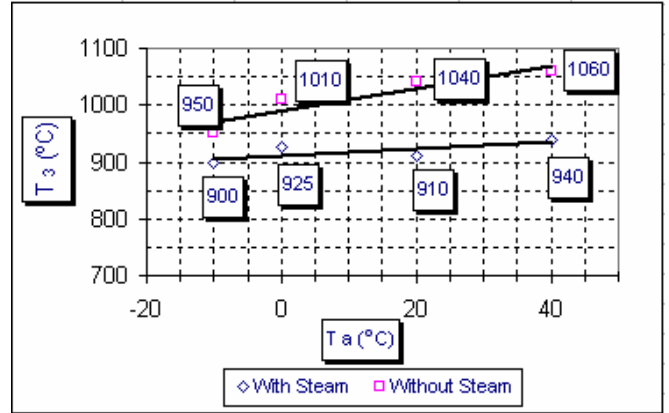

Figure 10. Variation of Turbine Inlet Temperature versus Ambient Temperature for GE-F5 Gas Turbine When $W_{out}=25MW$

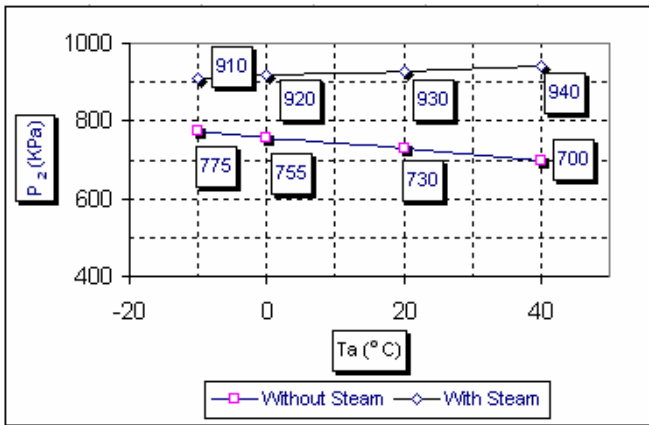

Figure 8. Variation of Compressor Discharge Pressure versus Ambient Temperature For GE-F5 Gas Turbine When $W_{out}=25MW$

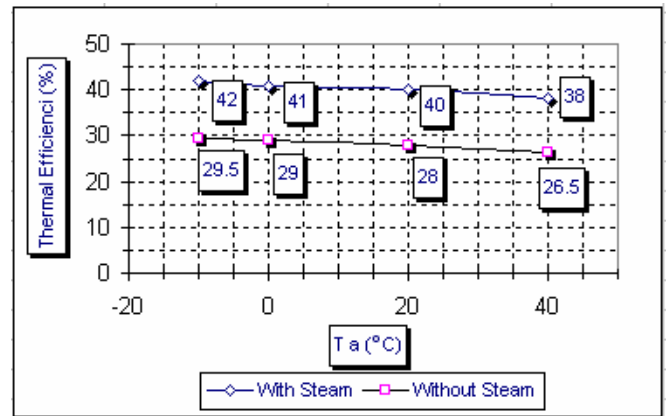

Figure 11. Variation of Thermal Efficiency versus Ambient Temperature For GE-F5 Gas Turbine When $W_{out}=25MW$

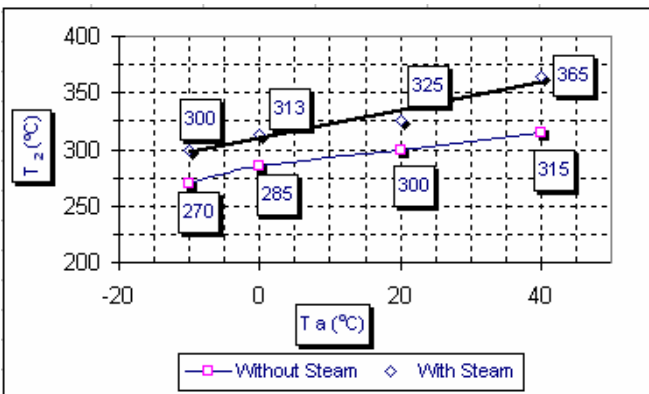

Figure 9. Variation of Compressor Discharge Temperature versus Ambient Temperature For GE-F5 Gas Turbine When $W_{out}=25MW$

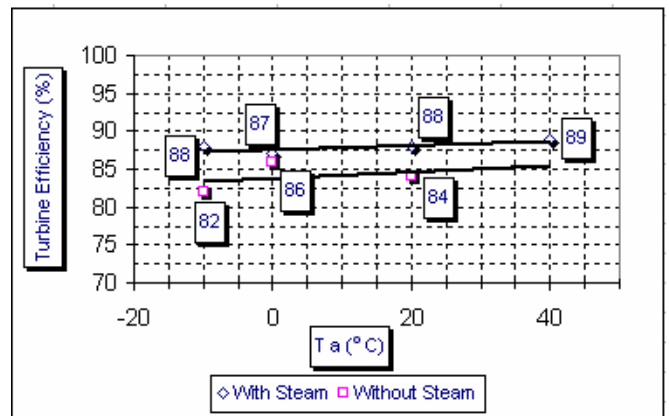

Figure 12. Variation of Turbine Efficiency versus Ambient Temperature For GE-F5 Gas Turbine When $W_{out}=25MW$

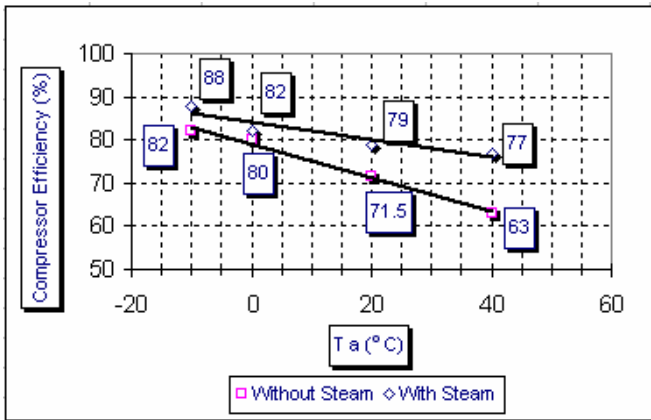

Figure13. Variation of Compressor Efficiency versus Ambient Temperature For GE-F5 Gas Turbine When $W_{out}=25MW$

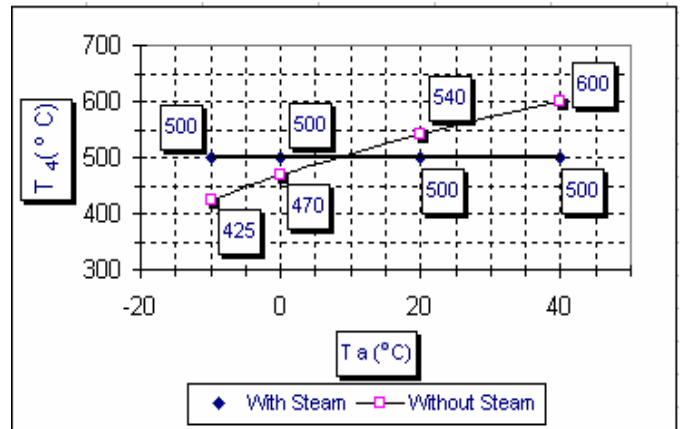

Figure16. Variation of Turbine Exhaust Temperature versus Ambient Temperature for GE-F5 Gas Turbine When $W_{out}=25MW$

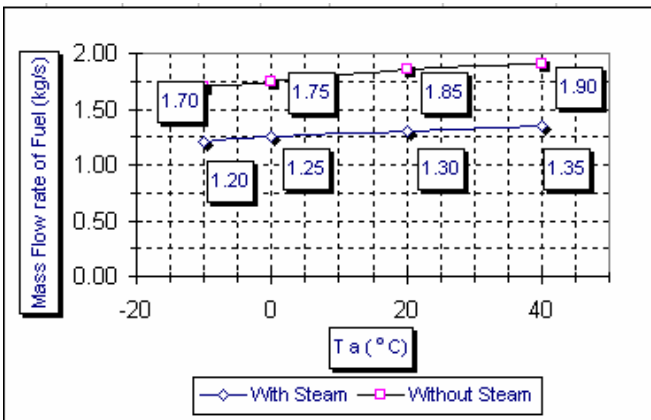

Figure14. Variation of Fuel Consumption versus Ambient Temperature For GE-F5 Gas Turbine When $W_{out}=25MW$

System Type	Fuel Cost	Water Treatment Cost	Total Costs
	\$/Year	\$/Year	\$/Year
Simple Cycle	3940432.8	0	3940432.8
VODOLEY System	2758302.9	102000	2860302.9

Table 2- Cost Comparison between Two Systems For 25 MW Output Power (Operation: 8 Hours/Day, 300 Days/Year)

ACKNOWLEDGMENTS

Partial funding for the work was provided by the Mashad Power Plant Research Department, Mashad, IRAN.

REFERENCES

- [1] Horlock J H, 1992, "Combined Power Plants Including Combined Cycle Gas Turbine (CCGT) plants", First Edition, Chapter 7 Page 256, printed in U.K, by B.P.C.C.
- [2] Carlos Hartel, Peter Pfeiffer, 2003, "Model Analysis of High-Fogging Effects on the Work of Compression", Proceeding of ASME Turbo Expo, Power For Land, Sea and Air, Atlanta, Georgia, USA.
- [3] Zheng Q., Li M. and Sun Y., 2003, "Thermodynamic Performance of Wet Compression and Regenerative (WCR) Gas Turbine", Harbin Engineering University, Harbin 150001 China, Proceeding of ASME Turbo Expo, Power for Land, Sea, and Air, Atlanta, Georgia.
- [4] Mohanty and G.Paloso JR, 1993, "Enhancing Gas Turbine Performance By Intake Air Cooling Using an Absorption Chiller", School of Environment, Resources and Development, Asian Institute of

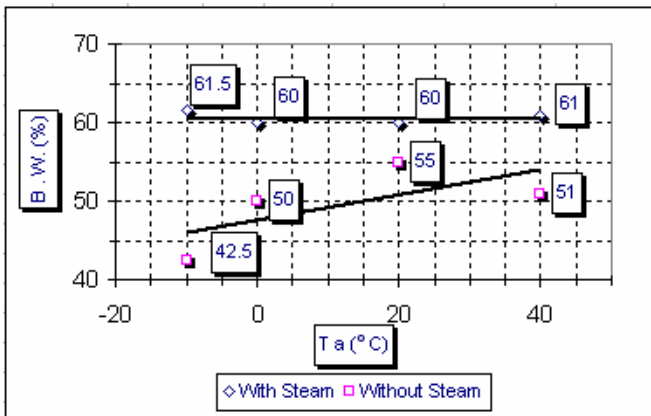

Figure15. Variation of Back Work versus Ambient Temperature for GE-F5 Gas Turbine When $W_{out}=25MW$

Technology, P.O.Box 2754, Bangkok 10501, Thailand.

- [5] Lumpugnano V., 2000, "Various Turbine Inlet Air Cooling Mechanical Refrigerant Systems, Comparison and Optimization", Design and Engineering Department, Stellar Group, Jacksonville, Proceeding of ASME International Joint Power Generation Conference, Miami Beach, Florida.
- [6] Rice, I.G, 1995, "Steam-Injected Gas Turbine Analysis: Steam Rates" ASME J. Eng. For Gas Turbine and Power, Vol. 117, pp. 347-353.
- [7] Larson, E. D. and Williams, R.H., 1987, Steam-Injected Gas Turbines, ASME J. Eng. , For Gas Turbines and Power, Vol. 109, p.55-63.
- [8] De Paepe, M. and Dick, E, 1997, Steam Injected Gas Turbines: Cycle Analysis and Feasibility of Water Recuperation, European Journal of Mechanical and Environmental Engineering, Vol.42, No.2, pp.67-77.
- [9] Kim T.S., Song C.H., Ro S.T., Kauh S.K., 1999, "Influence of Ambient Condition on Thermodynamic Performance of The Humid Air Turbine Cycle", Department of Mechanical Engineering, Seel National University, 151-742 South Korea.
- [10] Cârdu M., Baica M. , 2001, "Gas Turbine Installation with Total Water Injection in The Combustion Chamber", Energy Conversion and Management 2395-2404.
- [11] Ghazikhani M., Manshoori N., Tafazoli D , 2003, "Investigation of Ambient Temperature on GE-F5 Gas Turbine Performance", Iranian Journal of Energy, Vol. 7 pp. 7-15.
- [12] Ghazikhani M., 1993, "Spark ignition Engine Warm-Up and Emissions: Effect of Inlet Air Preheat and Steam Injection", Dept. of Fuel and Energy, The University of Leeds, Ph.D. Thesis.
- [13] Ghazikhani M., Manshoori N., Tafazoli D., 2002, "Investigation of Steam Injection in GE-F5 Gas Turbine", B.S. Thesis, Dept. of Mechanical Engineering, Ferdowsi University of Mashad, Mashad, IRAN.
- [14] Bassily A.M, 2001, "Effects of Evaporative Inlet and after Cooling on the Recuperated Gas Turbine Cycle", Nuclear Engineering Laboratory, USA.