

Tuned Liquid Column Dampers for Earthquake Oscillations of High-rise Structures Including Soil-Structure Interaction

Anoushirvan Farshidianfar¹, Saeed Soheili²

¹Associate Professor, Mechanical Engineering Department, Ferdowsi University of Mashhad; farshid@um.ac.ir

²PhD Candidate, Mechanical Engineering Department, Ferdowsi University of Mashhad; soheili78@yahoo.com

Abstract

This paper investigates the optimized parameters for the tuned liquid column dampers to decrease the earthquake vibrations of high-rise buildings. Considering soil effects, the soil-structure interaction (SSI) is involved in this model. The Tuned Liquid Column Damper (TLCD) is also utilized on the roof of the building. Since the TLCD is a nonlinear device, the time domain analysis based on nonlinear Newmark method is employed to obtain the displacement, velocity and acceleration of different stories and TLCD. To illustrate the results, Kobe earthquake data is applied to the model.

In order to obtain the best settings for TLCD, different parameters of TLCD are examined with constant mass quantity. The effective length, head loss coefficient, cross sectional ratio and length ratio of TLCD are assumed as the design variables. The objective is to reduce the maximum absolute and Root Mean Square (RMS) values of displacement and acceleration during earthquake vibration.

The results show that the TLCDs are very effective and beneficial devices for decreasing the oscillations of high-rise buildings. It is indicated that the soil type highly affects the suitable parameters of TLCD subjected to the earthquake oscillations. This study helps the researchers to the better understanding of earthquake vibration of the structures including soil effects, and leads the designers to achieve the optimized TLCD for the high-rise buildings.

Keywords: High-rise Structures, Earthquake Oscillations, Tuned Liquid Column Dampers, Soil-Structure Interaction.

Introduction

In recent years, the construction of new high-rise buildings are facilitated and developed in many countries due to the lighter and stronger materials. The typical examples are the Petronas Twin Tower (452m) in Kuala Lumpur, Malaysia, and Taipei101 Building (508m) in Taipei, Taiwan and the under-construction super-high building—Burj Dubai (807.7m) in Dubai. These tall and slender buildings are usually subjected to wind and earthquake vibrations, which may cause structural failure, discomfort to occupants and malfunction of equipment. Therefore, mitigation of wind and earthquake induced vibrations by using supplemental damping devices has been widely investigated. Moreover, the soil characteristics and the

interaction between soil and structure may greatly influence the structural response.

Among passive control devices, tuned mass dampers (TMDs) and tuned liquid dampers (TLCDs) have been widely employed for decreasing the wind and earthquake induced vibration of tall building structures.

The original idea of tuned liquid column damper (TLCD) was developed by Sakai et al. [1] for suppression of horizontal motion of structures. After that, quite a few research papers, namely Xu et al. [2], Hitchcock et al. [3], Balendra et al. [4], Min et al. [5] and Felix et al. [6], have verified its effectiveness for suppressing wind induced horizontal responses, among whom Hitchcock et al. [3] even investigated a general type of TLCDs that have non uniform cross-sections in the horizontal and vertical columns, termed as liquid column vibration absorber (LCVA). Recently, the application of TLCDs was further extended to the suppression of pitching motion for bridge decks (e.g., Xue et al. [7] and Wu et al. [8]). For the application to the control of horizontal motion toward implementation, some researchers have spent efforts on determining optimal TLCD designs, such as Chang et al. [9] and Chang [10] on undamped structures, Wu et al. [11,12] on damped structures, and Yalla et al. [13] on both damped and undamped structures. Their results of optimal parameters were provided for the situation when the loading on buildings is of a white-noise type, such as wide-banded along wind loads.

There are also some applications of TLCD technologies, including period adjustment mechanisms. By equipping a Tuned Liquid Column Damper with Period Adjustment Equipment (LCD-PA), the behavior of the liquid motion in the liquid column damper may be regulated [14]. Such a system has been installed in the top floor of the 26 story Hotel Cosima, now called Hotel Sofitel in Tokyo [15].

Considering soil effects, the structure response differs from the fixed base model. The oscillation energy is actually transferred to the soil through the foundation. Therefore, the soil and structure influence each other, which is called the soil-structure interaction (SSI). Various investigations are performed to study the SSI effects. For example, frequency domain analysis was performed by Xu and Kwok [16] to obtain the wind induced vibrations of soil-structure-damper system. Moreover, the frequency independent expressions are proposed by wolf [17] to determine the swaying and rocking dashpots, and the related springs of a rigid circular foundation. Recently, Liu et al. [18] developed

a mathematical model for time domain analysis of wind induced oscillations of a tall building with TMD considering soil effects. Soheili et al. [19] investigated the optimized parameters for the tuned mass dampers to decrease the earthquake vibrations of high-rise buildings including SSI effects.

Although numerous works are performed concerning TLCD effects, few investigations are carried out on the time response of high-rise buildings due to earthquake excitations. In fact, most researches are focused on the wind load effects, with employing the white noise loads and single degree-of-freedom (DOF) structures ignoring SSI effects. While the white noise loading model is not appropriate for studying the earthquake behavior of the structures, the single DOF building cannot present the behavior of the structures properly. Ignoring the SSI effects, the earthquake time response of tall buildings has usually been calculated employing fixed base models. These analyzes cannot reasonably predict the structural responses. Moreover, the optimal parameters of TLCDs are extremely related to the soil type. Therefore, the time domain analysis of structures consisting SSI effects is an advantageous process for the better understanding of earthquake oscillations and TLCD characteristics. Since the TLCDs are nonlinear devices, the nonlinear methods; such as the nonlinear Newmark method, should be employed to investigate the vibration behavior of the structures [20, 21].

In this paper, a mathematical model is developed for calculating the earthquake response of a high-rise building with TLCD. The model is employed to obtain the time response of 40 story building using TLCD. The effect of different parameters such as the effective length of the structure, the vertical to horizontal cross sectional and length ratio and the head loss coefficient of the TLCD are investigated. The parameters are calculated with and without soil structure interaction effects, using the multiple DOF model for the structure. This study may improve the researchers' knowledge of earthquake oscillations for a building with TLCD when SSI effects are considered.

Modeling of Tall Buildings

Figure 1 shows the N-storey structure with a TLCD and SSI effects. Mass and Moment of inertia for each floor are indicated as M_i and I_i , and those of foundation are shown as M_0 and I_0 , respectively. The stiffness and damping between floors are assumed as K_i and C_i , respectively. Damping of the swaying and rocking dashpots are represented as C_s and C_r , and the stiffness of corresponding springs are indicated as K_s and K_r , respectively. Time histories of displacement and rotation of foundation are respectively defined as X_0 and θ_0 , and displacement of each storey is shown as X_i . Figure 2 shows the TLCD configuration.

The kinetic energy for the structure is obtained in the following form:

$$\begin{aligned}
 T = & (1/2)M_0\dot{X}_0^2 + (1/2)I_0\dot{\theta}_0^2 + (1/2)M_1(\dot{X}_0 + Z_1\dot{\theta}_0 + \dot{X}_1)^2 \\
 & + (1/2)I_1\dot{\theta}_0^2 + (1/2)M_2(\dot{X}_0 + Z_2\dot{\theta}_0 + \dot{X}_2)^2 + (1/2)I_2\dot{\theta}_0^2 + \dots \\
 & + (1/2)M_N(\dot{X}_0 + Z_N\dot{\theta}_0 + \dot{X}_N)^2 + (1/2)I_N\dot{\theta}_N^2 + \rho A_v L_v \dot{y}_v^2 + \\
 & \rho A_v L_v (\dot{X}_0 + Z_N\dot{\theta}_0 + \dot{X}_N)^2 + (1/2)\rho A_h L_h (\dot{X}_0 + Z_N\dot{\theta}_0 + \dot{X}_N + \dot{y}_h^2)^2
 \end{aligned} \quad (1)$$

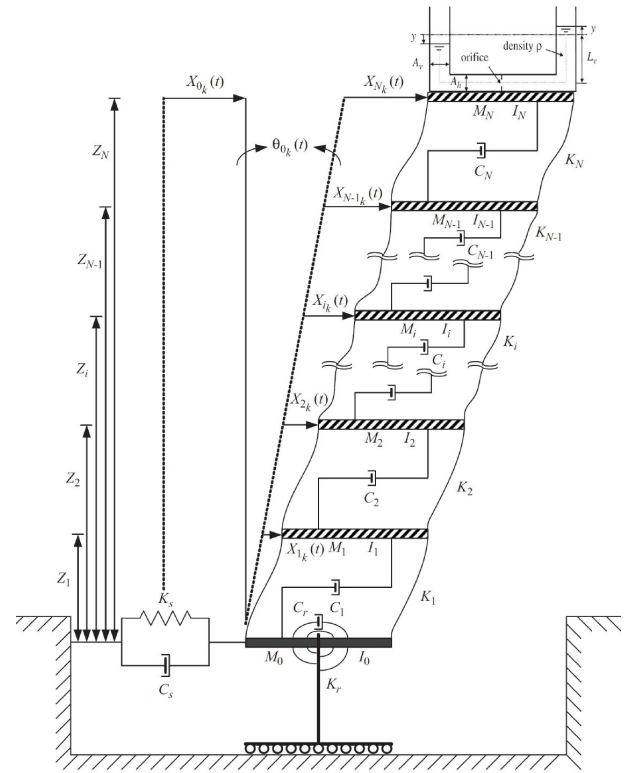

Figure 1: Shear building configuration

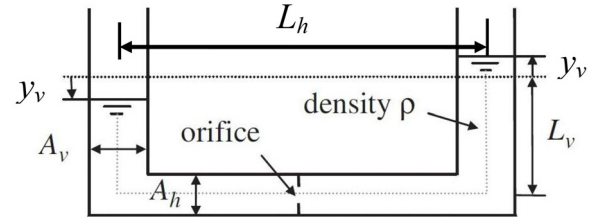

Figure 2: TLCD configuration

In this equation, A_v and A_h represent the cross sectional area of vertical and horizontal columns, respectively, while L_v and L_h show the vertical and horizontal column length. In addition, y_v and y_h indicate the vertical and horizontal displacement of fluid, and ρ is the fluid density.

The potential energy for the structure can be calculated as follows:

$$\begin{aligned}
 U = & (1/2)K_s X_0^2 + (1/2)K_r \theta_0^2 + (1/2)K_1 X_1^2 + (1/2)K_2 (X_2 - X_1)^2 \\
 & + \dots + (1/2)K_N (X_N - X_{N-1})^2 + \rho g A_v (L_v^2 + y_v^2)
 \end{aligned} \quad (2)$$

The non-conservative forces are achieved in the following form:

$$\begin{aligned}
 Q = & -C_s \dot{X}_0 - C_r \dot{\theta}_0 - C_1 \dot{X}_1 - C_2 (\dot{X}_2 - \dot{X}_1) - \dots \\
 & - C_N (\dot{X}_N - \dot{X}_{N-1}) - (1/2)\rho A_h \eta |\dot{y}_v| \dot{y}_v
 \end{aligned} \quad (3)$$

The cross sectional ratio of the vertical column versus horizontal column is defined as follows:

$$r = \frac{A_v}{A_h} \quad (4)$$

Similarly, the length ratio of the vertical column versus horizontal column is defined as follows:

$$n = \frac{L_v}{L_h} \quad (5)$$

The continuity condition between the horizontal and vertical column yields:

$$\dot{y}_h = r\dot{y}_v \quad (6)$$

Substituting A_v , L_v and \dot{y}_h in kinetic energy, potential energy and non-conservative force relations, they are achieved based on the area and length ratios.

Using Lagrange's equation, the equation of motion for a building shown in Figure 1 is obtained as follows [15]:

$$[m]\{\ddot{x}(t)\} + [c]\{\dot{x}(t)\} + [k]\{x(t)\} = -[m^*]\{1\}\ddot{u}_g \quad (7)$$

where $[m]$, $[c]$ and $[k]$ denote mass, damping and stiffness of the oscillating system. $[m^*]$ indicates acceleration mass matrix for earthquake and \ddot{u}_g is the earthquake acceleration. Considering SSI effects, the N-storey structure is a N+3 degree-of-freedom oscillatory system. For such building, the mass, damping and stiffness matrices are obtained by employing Lagrange's equation in the following form [18, 22]:

$$[m] = \begin{bmatrix} [M]_{(N-1) \times (N-1)} & \{0\}_{(N-1) \times 1} & \{0\}_{(N-1) \times 1} & [M]_{(N-1) \times 1} \\ & M_N + \rho A_h l'_e & \rho A_h l'_h r & M_N + \rho A_h l'_e \\ & & \rho A_h l'_e r & \rho A_h l'_h r \\ & & & \sum_{j=0}^N M_j + \rho A_h l'_e \\ \text{symmetry} & & & \\ & & [MZ]_{(N-1) \times 1} & \\ & & (M_N + \rho A_h l'_e) Z_N & \\ & & (\rho A_h l'_h r) Z_N & \\ & & \sum_{j=1}^N M_j Z_j + (\rho A_h l'_e) Z_N & \\ & & \sum_{j=0}^N (I_j + M_j Z_j^2) + (\rho A_h l'_e) Z_N^2 & \end{bmatrix} \quad (8)$$

$$[k] = \begin{bmatrix} [K]_{N \times N} & \{0\}_{N \times 1} & \{0\}_{N \times 1} & \{0\}_{N \times 1} \\ & 2\rho g A_h r & 0 & 0 \\ & & K_s & 0 \\ \text{symmetry} & & & K_r \end{bmatrix} \quad (9)$$

$$[c] = \begin{bmatrix} [C]_{N \times N} & \{0\}_{N \times 1} & \{0\}_{N \times 1} & \{0\}_{N \times 1} \\ & (1/2)\rho A_h r^2 \eta |\dot{y}_v| & 0 & 0 \\ & & C_s & 0 \\ \text{symmetry} & & & C_r \end{bmatrix} \quad (10)$$

$$[m^*] = \begin{bmatrix} \{0\}_{(N-1) \times (N+1)} & \{M\}_{(N-1) \times 1} & \{0\}_{(N-1) \times 1} \\ & M_N + \rho A_h l'_e & 0 \\ & \rho A_h l'_h r & 0 \\ & \sum_{j=0}^N M_j + \rho A_h l'_e & 0 \\ & \sum_{j=1}^N M_j Z_j + (\rho A_h l'_e) Z_N & 0 \end{bmatrix} \quad (11)$$

In the mentioned equations, l_e and l'_e respectively show the effective and semi-effective length of the TLCD, which are calculated as follows:

$$l_e = 2L_v + rL_h \quad (12)$$

$$l'_e = 2rL_v + L_h$$

It is clear that the damping matrix is a nonlinear one, due to the nonlinear damping of TLCD. The natural frequency of the TLCD is obtained in the following form [11, 12]:

$$\omega_{TLCD} = \sqrt{\frac{2g}{l_e}} \quad (13)$$

Ignoring the SSI effects, rows and columns N+2 and N+3 are neglected, and the mentioned matrices are reduced to (N+1)×(N+1) dimensional matrices.

According to Rayleigh proportional damping, the damping matrix of N-storey structure can be represented as follows:

$$[c]_{N \times N} = A_0 [m]_{N \times N} + A_1 [k]_{N \times N} \quad (14)$$

in which A_0 and A_1 are Rayleigh damping coefficients.

The displacement vector $\{x(t)\}$ including both displacement and rotation of floors and foundation as well as TLCD motion can be represented as follows:

$$\{x(t)\} = \{X_1(t) \ X_2(t) \ \dots \ X_N(t) \ y_v(t) \ X_0(t) \ \theta_0(t)\}^T \quad (15)$$

The parameters C_s , C_r , K_s and K_r can be obtained from soil properties (i.e. poisson's ratio ν_s , density ρ_s , shear wave velocity V_s and shear modulus G_s) and radius of foundation R_0 [18].

In this paper, Kobe earthquake acceleration spectrum is applied to the structure, and time response of TLCD and building are calculated based on nonlinear Newmark integration method [21].

Illustrative Example

The methodology outlined previously is employed to calculate the structural response of a 40-storey building with TLCD. Table 1 shows the structure parameters [18]. The stiffness K_i linearly decreases as Z_i increases. The TLCD is installed on the top of building for the better damping of vibrations.

Table 1: Structure parameters [18]

No. of stories	40
storey height (Z_i)	4 m
storey mass (M_i)	9.8×10^5 kg
Storey moment of inertia (I_i)	1.31×10^8 kgm ²
Storey stiffness	$K_1 = 2.13 \times 10^9$ N/m $K_{40} = 9.98 \times 10^8$ N/m $K_{40} \leq K_i \leq K_1$
Foundation radius (R_0)	20 m
Foundation mass (M_0)	1.96×10^6 kg
Foundation moment of inertia (I_0)	1.96×10^8 kgm ²

In this study, three types of ground states, namely soft, medium and dense soil are examined. A structure with a fixed base is also investigated. The soil and foundation properties are presented in Table 2.

Table 2: Parameters of the soil and foundation [18]

Soil Type	Swaying Damping C_s (Ns/m)	Rocking Damping C_r (Nsm)	Swaying Stiffness K_s (N/m)	Rocking Stiffness K_r (N/m)
Soft Soil	2.19×10^8	2.26×10^{10}	1.91×10^9	7.53×10^{11}
Medium Soil	6.90×10^8	7.02×10^{10}	1.80×10^{10}	7.02×10^{12}
Dense Soil	1.32×10^9	1.15×10^{11}	5.75×10^{10}	1.91×10^{13}

Table 3 represents the first 3 natural and damped frequencies of the structure, considering and ignoring SSI effects. The TLCD design variables set in such a way that all the first 3 frequencies of the structure are covered. The search area settings are shown in Table 4.

Table 3: Natural and damped frequencies of the structure

ω		ω_1	ω_2	ω_3
Soft Soil	With Damping	-0.02±1.08	-0.24±4.45	-0.62±7.42
	Without Damping	1.09	4.44	7.40
Medium Soil	With Damping	-0.02±1.54	-0.21±4.57	-0.58±7.55
	Without Damping	1.54	4.58	7.58
Dense Soil	With Damping	-0.02±1.60	-0.21±4.58	-0.58±7.57
	Without Damping	1.61	4.59	7.59
Fixed Base	With Damping	-0.03±1.64	-0.21±4.59	-0.58±7.58
	Without Damping	1.65	4.60	7.60

Table 4: The parameter settings for TLCD

$0.1(m) \leq l_e \leq 33.1(m)$
$0 \leq \eta \leq 51$
$0.01 \leq r \leq 3.01$
$0.01 \leq n \leq 0.51$

As mentioned before, Kobe earthquake data is employed to investigate the effect of various parameters for TLCD device. Figure 3 shows Kobe earthquake acceleration spectrum (m^2/s vs. sec), which was about 7 Richter and occurred in 16th January 1995 in Kobe.

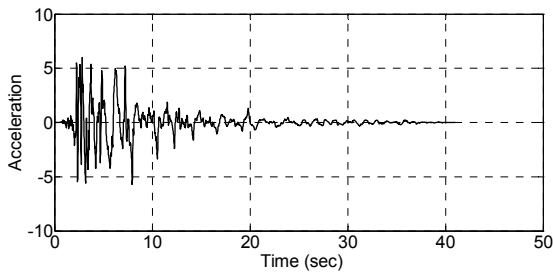

Figure 3: Kobe earthquake acceleration spectrum

The objective is to decrease the maximum absolute and root mean square (RMS) values of the displacement and acceleration of stories during earthquake oscillation.

Results and Discussions

Considering that increasing the mass ratio of TLCD to structure would increase the efficiency of TLCD [11, 12], the mass ratio is set constant as 6.5% of the first modal mass in all cases. In order to investigate the effect of l_e and η , the area and length ratios are assumed as $r=1$ and $n=1$. Table 5 shows the best values of l_e for decreasing the maximum absolute and RMS values of displacement and acceleration, for different soil types. This table indicates that except for the RMS of

displacement, the minimum values are obtained when $l_e=0.7$, i.e. $\omega_{TLCD}=5.3$ (rad/s). However, the best values of l_e for the RMS of displacement is decreased with increasing the soil stiffness (except for the soft soil), which results in $\omega_{TLCD}=1.44-1.52$ (rad/s).

Table 5: The optimized TLCD parameters

Soil Type	Best Values	Absolute Values		RMS Values		
		u_{max}	\ddot{u}_{max}	u_{max}	\ddot{u}_{max}	
Soft Soil	l_e (m)	0.7	0.7	1.6	0.7	
	$l_e=0.7$ (m)	n	0.30	0.01	0.01	0.01
		r	0.21	0.81-1.01	2.61-3.01	0.61
	$l_e=1.6$ (m)	n	0.51	0.11	0.01	0.51
r		0.01	1.41-1.81	1.21-1.81	0.01	
Medium Soil	l_e (m)	0.7	0.7	9.4	0.7	
	$l_e=0.7$ (m)	n	0.11	0.19	0.01	0.01
		r	0.61-0.81	0.81-1.21	0.81-1.21	0.61
	$l_e=9.4$ (m)	n	0.01	0.51	0.01	0.09
r		1.01	0.01	3.01	0.01	
Dense Soil	l_e (m)	0.7	0.7	9.1	0.7	
	$l_e=0.7$ (m)	n	0.09	0.25	0.01	0.01
		r	0.61-0.81	1.01-1.21	0.81-1.01	0.61-0.81
	$l_e=9.1$ (m)	n	0.01	0.51	0.01	0.11
r		1.01	0.01	3.01	0.01	
Fixed Base	l_e (m)	0.7	0.7	8.5	0.7	
	$l_e=0.7$ (m)	n	0.09	0.29	0.01	0.01
		r	0.61	1.01-1.21	0.81-1.01	0.61-0.81
	$l_e=8.5$ (m)	n	0.01	0.51	0.01	0.13
r		0.81-1.01	0.01	3.01	0.01	

Figures 4 and 5 show the changes of maximum absolute and RMS values of displacement for medium soil, respectively.

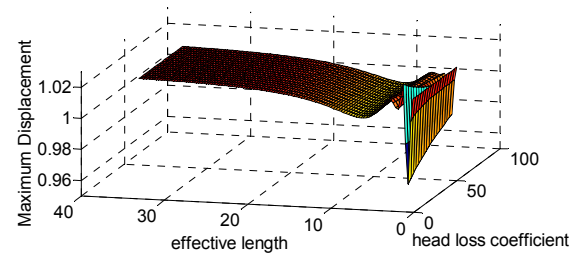

Figure 4: Maximum displacement spectrum

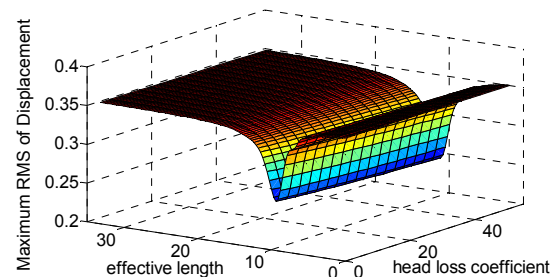

Figure 5: Maximum RMS of displacement spectrum

Considering head loss coefficient, it can be seen that the objective quantities are enhanced by raising η . However, the RMS of displacement is an exception; since its amount is reduced by increasing η .

Considering $l_e=0.7(m)$ (the best effective length except for RMS of displacement), the best r ratio is increased by increasing the soil stiffness, except for the RMS of displacement; in which the best r ratio is decreased. It also can be seen that the length ratio n should be decreased for smaller displacement, and should be increased for smaller acceleration, by the increment of soil stiffness. In order to obtain the least RMS values of displacement and acceleration, the length ratio is to be decreased to the least possible quantity.

Considering $l_e=8.5-9.4(m)$ (the best effective length for RMS of displacement), the r ratio is to be set to the least possible quantity for obtaining the minimum acceleration values, and it should be set to the highest feasible quantity for achieving the minimum RMS of displacement. However, the best the best setting to reach the minimum displacement value is $r=1$.

On the other hand, to reduce the displacement RMS and absolute values, the length ratio is to be decreased to the least possible quantity, and to reduce the absolute acceleration values, it should be increased to the greatest quantities. Nevertheless, the length ratio is to be raised slightly for the soil with higher stiffness; to decrease the RMS of acceleration values. In most cases, the soft soil is an exception and should be considered separately. Figures 6 and 7 show the absolute and RMS values of acceleration for the medium soil and $l_e=0.7(m)$, respectively.

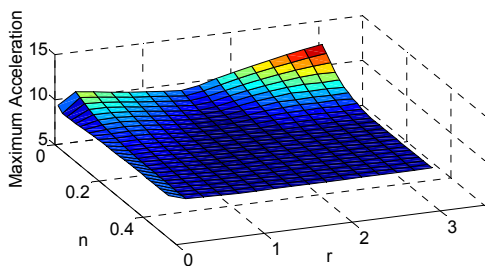

Figure 6: Maximum acceleration spectrum for $l_e=0.7(m)$

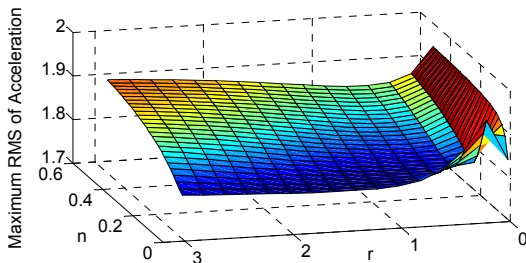

Figure 7: Maximum RMS of acceleration spectrum for $l_e=0.7(m)$

Table 6 shows the maximum values of the objective functions outlined previously for the structure without TLCD, and table 7 indicates the mentioned values for the structure equipped with TLCD. According to this table, the maximum feasible reduction is about 13% and 31% for the absolute and RMS values of displacement, and 23% and 17% for those of acceleration,

respectively. However, the soft soil shows less reduction, which means that the TLCD is less effective in soft soils.

Table 6: Vibration without TLCD

Soil Type	Absolute Values		RMS Values	
	$u_{\max} (m)$	$\ddot{u}_{\max} (m^2/s)$	$u_{\max} (m)$	$\ddot{u}_{\max} (m^2/s)$
Soft Soil	0.76	9.55	0.16	1.99
Medium Soil	1.06	11.29	0.35	2.16
Dense Soil	1.06	11.40	0.35	2.18
Fixed Base	1.06	11.44	0.35	2.19

Table 7: Vibration with TLCD

Soil Type	Best Values	Absolute Values		RMS Values	
		%Reduction		%Reduction	
		u_{\max}	\ddot{u}_{\max}	u_{\max}	\ddot{u}_{\max}
Soft Soil	$l_e=0.7$	13.11	7.57	11.57	16.83
	$l_e=1.6$	12.35	6.07	12.70	7.82
Medium Soil	$l_e=0.7$	13.87	22.20	-1.03	17.26
	$l_e=9.4$	12.37	13.58	34.83	10.40
Dense Soil	$l_e=0.7$	13.62	23.02	0.64	17.18
	$l_e=9.1$	12.42	12.47	31.52	10.34
Fixed Base	$l_e=0.7$	13.51	23.41	5.23	17.26
	$l_e=8.5$	12.44	11.74	31.66	10.50

Conclusions

In this paper, a mathematical model is developed to obtain the earthquake response of a high-rise building with TLCD, considering SSI effects. The model is based on the time domain analysis. Since the damping of TLCD is a nonlinear term, the nonlinear Newmark method is employed to perform the time history analysis. The effective length, head loss coefficient, cross sectional ratio and length ratio of TLCD are assumed as the design variables, and the objective is to decrease the maximum absolute and RMS values of displacement and acceleration.

The results show that there is a close relationship between soil and optimized parameters of TLCD. The TLCD frequency is to be tuned near the first natural frequency of the structure, or approximately about the main frequency of earthquake. The optimized quantity of other parameters can be also obtained considering soil effects.

It is also shown that the TLCDs are advantageous devices for earthquake vibration mitigation of high-rise buildings. This study improves the understanding of earthquake oscillations regarding soil effects, and helps the designers to achieve the optimized TLCD for high-rise buildings.

References

- [1] Sakai, F., Takaeda, S., and Tamaki, T., 1989, "Tuned liquid column damper—new type device for suppression of building vibration", *Proceedings of International Conference on High-rise Buildings*, Nanjing, China, pp.926–931.
- [2] Xu, Y.L., Samali, B., and Kwok, K. C. S., 1992, "Control of along wind response of structures by mass and liquid dampers", *ASCE Journal of Engineering Mechanics*, 118(1), pp.20–39.
- [3] Hitchcock, P.A., Kwok, K.C.S., and Watkins, R. D., 1997. "Characteristics of liquid column vibration absorbers (LCVA)—I, II", *Engineering Structures* 19, pp.126–144.
- [4] Balendra, T., Wang, C.M., and Rakesh, G., 1999, "Effectiveness of TLCD on various structural systems", *Engineering Structures* 21(4), pp.291–305.
- [5] Min, K.W., Kim, H.S., Lee, S.H., Kim, H., and Ahn, S.K., 2005, "Performance evaluation of tuned liquid column dampers for response control of a 76-story benchmark building", *Engineering Structures* 27(7), pp.1101–1112.
- [6] Felix, J.L.P., Balthazar, J.M.R., Brasil, M.L.R.F., 2005, "On tuned liquid column dampers mounted on a structural frame under a non-ideal excitation", *Journal of Sound and Vibration* 282(3–5), pp.1285–1292.
- [7] Xue, S.D., Ko, J.M., and Xu, Y.L., 2000, "Tuned liquid column damper for suppressing pitching motion of structures", *Engineering Structures* 23(11), pp.1538–1551.
- [8] Wu, J.C., Wang, Y.P., Lee, C.L., Liao, P.H., and Chen, Y.H., 2008, "Wind-induced interaction of a non-uniform tuned liquid column damper and a structure in pitching motion", *Engineering Structures* 30(12), pp.3555–3565.
- [9] Chang, C.C., and Hsu, C.T., 1998, "Control performance of liquid column vibration absorbers", *Engineering Structures* 20 (7), pp.580–586.
- [10] Chang, C.C., 1999, "Mass dampers and their optimal designs for building vibration control", *Engineering Structures* 21, pp.454–463.
- [11] Wu, J.C., Shih, M.H., Lin, Y.Y., and Shen, Y.C., 2005, "Design guidelines for tuned liquid column damper for structures responding to wind", *Engineering Structures* 27 (13), pp.1893–1905.
- [12] Wu, J.C., Chang, C.H., and Lin, Y.Y., 2009, "Optimal designs for non-uniform tuned liquid column dampers in horizontal motion", *Journal of Sound and Vibration* 326, pp.104–122.
- [13] Yalla, S., and Kareem, A., 2000, "Optimum absorber parameters for tuned liquid column dampers", *ASCE Journal of Structural Engineering* 126(8), pp.906–915.
- [14] Shimizu, K. and Teramura, A., 1994, "Development of vibration control system using U-shaped tank", *Proceedings of the 1st International Workshop and Seminar on Behavior of Steel Structures in Seismic Areas*, Timisoara, Romania:7.25-7.34.
- [15] Kareem, A., Kijewski, T., Tamura, Y. "Mitigation of Motions of Tall Buildings with Specific Examples of Recent Applications", *Journal of Wind and Structures* 2, pp.132–284
- [16] Xu, Y.L., Kwok, K.C.S., 1992, "Wind-induced response of soil–structure–damper systems", *Journal of Wind Engineering and Industrial Aerodynamics*, 43 (1–3), pp. 2057–2068.
- [17] Wolf, J.P., 1994, *Foundation Vibration Analysis Using Simple Physical Models*, Prentice-Hall, Englewood Cliffs, NJ.
- [18] Liu, M.Y., Chiang, W.L., Hwang, J.H., and Chu, C.R., 2008, "Wind-induced vibration of high-rise building with tuned mass damper including soil–structure interaction", *Journal of Wind Engineering and Industrial Aerodynamics*, 96, pp. 1092–1102.
- [19] Soheili, S., Abachizadeh, M. and Farshidianfar, A., 2010, "Tuned Mass Dampers for Earthquake Oscillations of High-rise Structures Using Ant Colony Optimization Technique", *18th Annual International Conference on Mechanical Engineering-ISME2010*, May, Sharif University of Technology, Tehran, Iran.
- [20] Chopra, A. K., 1995, *Dynamics of Structures: Theory and Application to Earthquake Engineering*, Prentice Hall Inc., 4th Edition, New Jersey.
- [21] Subbaraj, K., and Dokainish, M.A., 1989, "A Survey of Direct Time-Integration Methods in Computational Structural Dynamics-II. Implicit Methods", *Computers and Structures* Vol. 32, No. 6. pp.1387-1401.
- [22] Thomson, W.T., Dahleh, M.D., 1997, *Theory of Vibration with Applications*, Prentice Hall Inc., 5th ed., London.