Experimental comparison of applying different theories in elasticity for determination of the elasticity modulus of agricultural produce, Pumpkin seed as a case study

B. Emadi, R. khodabakhshian^{*}, M.H. Abbaspour Fard and H. Sadrnia

¹Department of Agricultural Machinery, Ferdowsi University of Mashhad, P.O. Box. 91775-1163 Mashhad, Iran

B. Emadi, R. khodabakhshian, M.H. Abbaspour Fard and H. Sadrnia (2011) Experimental comparison of applying different theories in elasticity for determination of the elasticity modulus of agricultural produce, Pumpkin seed as a case study. Journal of Agricultural Technology 7(6): 1495-1508.

The behavior of agricultural seeds under compression loads was studied and revealed that their useful properties such as *Poisson's ratio* and elastic modulus which can be applied in design of their processing equipment. The feasibility of using different elasticity theories including *Hook's* theory, *Hertz* theory and *Boussinesq's* theory for evaluation of the modulus of elasticity of agricultural produce was investigated in this research. Two major commercial Iranian varieties of pumpkin seed namely *Zaria* and *Gaboor* were used as a case study. Their general behavior under compressive loads was also reported. These values ranged from 61.15×10^5 to 91.6 Mpa and 89.43×10^5 to 119.88 Mpa for *Zaria* and *Gaboor* varieties, respectively. The *Hertz* theory was found more applicable due to good agreement between its theoretical and experimental results. Also, among the four investigated methods of loading the highest values in elastic modulus of pumpkin seed belonged to parallel plate method in *Hertz* theory while cylindrical indenter in *Boussinesq's* theory showed the lowest values. Then, the obtained force-deformation curves for pumpkin seed were interpreted in several different ways to select the best theory. The methods of interpretation of the force-deformation curves were based on the *Hertz* theory and utilized the complete curve were preferred to those methods which "linearize" the initial part of the curve.

Key words: Theory of elasticity, elastic modulus, pumpkin seed, force-deformation curve.

Introduction

Knowledge of apparent elastic properties such as *Poisson's ratio* and elastic modulus of agricultural produce are important for the prediction of their load-deformation behavior. These elastic properties could be used to compare the relative strengths of different biomaterials and investigating these technological characteristics will contribute to the design of processing

^{*} corresponding author: R. khodabakhshian; e-mail: ra_kh544@stu-mail.um.ac.ir

equipment (Mohsenin, 1986). Owing to the complex shape of most agricultural produce and their associated complex structure, the determination of a reliable elastic modulus presents a number of problems. For instance, one of the major problems for determination of the modulus of the elasticity of agricultural produce is that they display characteristic of both elastic solids and viscous liquid, so they are called *viscoelastic*. However, many researches have found that when the small loads are occurred in short times, these problems can be overcome, to a certain extent, using methods based on elasticity theory (Levin *et al.*, 1959; Huff, 1967; Shelef and Mohsenin, 1967; Fridley *et al.*, 1968; Shelef and Mohsenin, 1969; Arnold and Roberts, 1969; Arnold and Mohsenin, 1971; Misra and Young, 1981; Balastreire *et al.*, 1982; Jindal and Techasena, 1985; Bargale *et al.*, 1994; Bargale and Irudayaraj, 1995; Khzaie, 2002; Hicsasmaz and Rizvi, 2005; Burubai *et al.*, 2008; Kiani *et al.*, 2009).

Literature review has been done by the authors indicates that many of studies have determined elastic modulus of agricultural produce from the force-deformation curves using the *Boussinesq* and *Hertz* theories (Mohsenin, 1986). Meanwhile, much of these studies result in widely varying values being obtained. Shelef and Mohsenin (1967), for example, found values for the apparent modulus of elasticity of *Seneca* wheat grains at 10 percent dry basis, ranging from 11.2×10^2 to 58.1×10^2 Pa. Burubai *et al.* (2008) reported modulus of elasticity of African *nutmeg* as a function of moisture content and loading rate from an average value of 201.5 to 41.30 Pa, in view of this apparent variability, the techniques for performing axial compression tests on intact, convex-shaped agricultural produce which have been used in the past should be examined with a view to making recommendations to reduce this variability. As it can be found from literature review, despite of an extensive search on *elastic modulus* of agricultural produce, no published literature was found on the selection of the best method among methods existing in elasticity theory for determining of elastic modulus of agricultural produce. Hence, the object of this study was investigation the applicability of three different methods existing in elasticity theory namely *Hook's* theory, *Hertz* theory and *Boussinesq's* theory for evaluation of the modulus of elasticity of agricultural produce (Pumpkin seed as a case study). Selection the best theory to be able to explain well the behavior of agricultural produce (pumpkin seed as a case study) was also the other object of this study.

Materials and methods

The samples selected from two major commercial Iranian varieties of pumpkin seed namely *Zaria* and *Gaboor*. These cultivars were obtained randomly from different regions of Khorasan Razavi province, Iran, during autumn season in 2010 (Fig. 1). One hundred seeds of pumpkin were randomly selected from each variety so that twenty seeds were applied for each of five studied methods. The seeds were manually cleaned to remove all foreign matters such as dust, dirt, stones, immature and broken seeds. The initial moisture content of seeds were determined using the standard hot air oven method with a temperature setting of $105 \pm 1^\circ\text{C}$ for 24 h (Altuntas *et al.*, 2005; Coskun *et al.*, 2005, Khodabakhshian *et al.*, 2010). The initial moisture content of the seeds was found 7.8% and 7.2% d.b for *Zaria* and *Gaboor*, respectively. A Universal Testing Machine (Model H5KS, Tinius Olsen Company) equipped with a 5000 N compression load cell and integrator was used for the compression test of the pumpkin seed (Fig 2). Consequently, compression tests data were used with three elastic theories of contacting bodies: *Hook*, *Hertz* and *Boussinesq* theories.



Fig 1. The size categories of two Iranian varieties of pumpkin seed.



Fig 2. Universal test machine used in the compression test.

Hook's theory

For ideal elastic materials, stress (σ) is directly proportional to strain (ε) and *Young's modulus* (E) based on *Hook's law* (Crandall *et al.*, 1978) is given by Eq. (1). *Young's modulus* is properly determined from the initial section of the stress-strain curve at relatively low deformation. Thus only the section of the deformation curve below the initial yield point is considered and the value obtained is referred to as the elastic modulus:

$$E = \frac{\sigma}{\varepsilon} = \frac{Pl}{\delta A} \quad (1)$$

In order to use this theory, pumpkin seeds were shaped at both ends so that cylindrical specimens obtained. Then, the cylindrical specimens were supposed to certain load for attaining force-deformation curve. Lastly, with knowing the values of load used (P), elastic deformation (δ), initial length of the specimen (l) and contact area of specimen (A) that was determined by coating the surface area of the plate with paint and measuring the final area of contact on the seed, modulus of the elasticity were calculated from Eq. (1). Many researchers used this theory for determination of elastic modulus of agricultural produce (Arnold and Roberts, 1969; Shitanda *et al.*, 2002; Khzaie, 2002).

Hertz theory

In 1896 *Heinrich Hertz* (Hertz, 1896) proposed a solution for contact stresses in two elastic isotropic bodies, such as the case of two spheres of the same material touching each other. In this problem, *Hertz* attempted to find answers to such questions as the form of the surface of pressure, the magnitude of the curve of pressure, normal pressure distribution on the surface of pressure, the magnitude of the maximum pressure, and the approach of the centers of the bodies under pressure. *Hertz's* theory for contact stresses between two elastic bodies subjected to uniaxial compression, as reviewed by Kosma and Cunningham (1962) and Mohsenin (1986) was employed for calculation of the modulus. According to this theory, the deformation of the two convex bodies is given by

$$D = \frac{K}{2} \left[\frac{9}{16\pi^2} P^2 (Q_1 + Q_2)^2 \left(\frac{1}{R_1} + \frac{1}{R_1'} + \frac{1}{R_2} + \frac{1}{R_2'} \right) \right]^{1/3} \quad (2)$$

Where:

D = approach of body centers;

K = constant determined from elliptic integral tables;

P = applied compressive load;

$$Q = \frac{4(1 - \mu^2)}{E}$$

μ = Poisson's ratio;

E = Elastic modulus,

R = major radius of curvature;

R' = minor radius of curvature;

1 denotes primary convex body

2 denotes secondary convex body

The use of this equation requires that eight fundamental assumptions be satisfied, which have been listed in detail by Kozma and Cunningham (1962). The first known application of the *Hertz* theory for contact stresses in agricultural produce is reported by Shpolyanskaya (1952) for determination of modulus of deformability of the wheat grain compressed between two parallel plates. Application of this assumption to agricultural produce was discussed by Morrow and Mohsenin (1966). Meantime, many researches have revealed that when piles of agricultural produce in the form of spherical bodies are considered, the *Hertz* method can be used to determine the contact forces, displacements on individual units and finally elastic modulus (Shelef and Mohsenin, 1967; Shelef and Mohsenin, 1969; Arnold and Roberts, 1969; Arnold and Mohsenin, 1971; Khzaie, 2002; Burubai *et al.*, 2008; Kiani *et al.*, 2009). They used this theory for agricultural produce in two states depend on specimen's condition, type and shape of loading. They also simplified Eq. (2) to yield an expression for calculation of the modulus in each state.

Parallel plates (whole specimen)

In this state, whole specimen of pumpkin seeds were fixed to a metal plate and then a compressive load were applied by means of parallel plates. For first time, Morrow and Mohsenin (1966); Arnold and Roberts (1966) discussed the use of the *Hertz* theory for plate type tests on fruits and wheat *germs*, respectively. Since the flat plate results in a flat plane across the area of contact with specimen, Eq. (2) can be simplified to describe the plate test in either one of two ways. First, the equation may be reduced by assuming that two identical spheres pressed together are mirror images and deform equal amounts, second, the plate can be assumed to be a sphere of infinite radiuses with a modulus of elasticity which is very great compared to that of a specimen, and all deformation can be assumed to occur within the specimen. Both ways of reasoning can be used to reduce the equation to:

$$E = \frac{0.5P(1-\mu^2)}{\Delta L^{\frac{3}{2}}} \left(\frac{1}{R} + \frac{1}{R'} \right)^{\frac{1}{2}} \quad (3)$$

Since, the pumpkin seeds were loaded on the curved surface at the point of maximum height (H), their radii of curvature (R and R') are, by approximation, as shown in Fig (3).

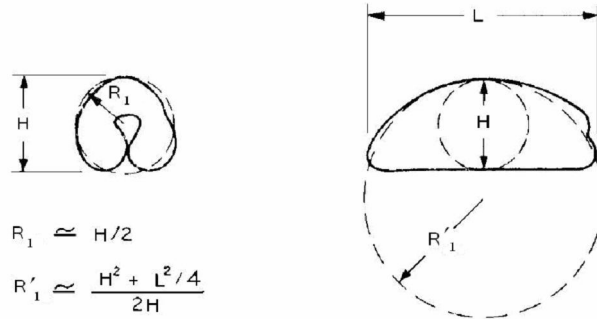

Fig 3. Estimation of the radii of curvature of pumpkin seed.

It should be mentioned that many researchers have used this method to determine the elastic modulus of agricultural produce (Shelef and Mohsenin, 1967 for wheat; Arnold and Roberts, 1969 for wheat; Bargale *et al.*, 1994 for lentil; Bargale and Irudayaraj, 1995 for barely kernels; Khzaie, 2002 for pea; Kiani *et al.*, 2009 for red bean grains).

Spherical Indenter Contact

Timbers *et al.* (1965) have reported that a measurement of elastic modulus can be obtained by application of the theory of elasticity to an Indenter contact test on the cheek of fruits. The results reported derived from the case of a rigid die in the form of a circular cylinder (*Indenter*) pressed against the plain boundary of a semi-infinite elastic solid. Shelef and Mohsenin (1967) used this method for determination of elastic modulus of wheat. In this research a compressive load was applied by means of a steel spherical indenter having a 1.6 mm diameter in two states depending on specimen's condition and Eq. (2) was simplified to calculate the modulus in each state as below:

Whole specimen

$$E = \frac{0.5P(1 - \mu^2)}{\Delta L^{\frac{3}{2}}} \left(\frac{1}{R} + \frac{1}{R'} + \frac{4}{d} \right)^{\frac{1}{2}} \quad (4)$$

Where d is the diameter of the spherical indenter.

Flat specimen

$$E = \frac{0.5P(1 - \mu^2)}{\Delta L^{\frac{3}{2}}} \left(\frac{4}{d} \right)^{\frac{1}{2}} \quad (5)$$

Boussinesq's theory

The original solution for evaluation of stress-strain relations for semi-infinite bodies loaded by cylindrical rigid indenters was proposed by Boussinesq (1885). Later, this solution was expanded by Timoshenko and Goodier (1951). Timoshenko and Goodier (1951) proved that with knowing the values of load used (P), elastic deformation (δ), *Poisson's ratio* (μ) and the diameter of the die ($2a$), modulus of the elasticity can be calculated from Eq. (6):

$$E = \frac{P(1 - \mu^2)}{2a\delta} \quad (6)$$

In this series of tests the pumpkin seed were shaped at both ends so that flat specimens obtained then they were subjected to concentrated compressive loads by means of a cylindrical indenter with a 1.4 mm diameter. Arnold and Roberts (1969) and Shitanda *et al.* (2002) used this theory for determination of elastic modulus of wheat and rice, respectively.

Results and discussion***Evaluation the studied theories using elasticity modulus of pumpkin seed***

The value of modulus of elasticity of pumpkin seed was determined by three different methods existing in elasticity theory namely *Hook's* theory, *Hertz* and *Boussinesq's* theory. These values ranged from 61.15×10^5 to 91.6 Mpa and 89.43×10^5 to 119.88 Mpa for *Zaria* and *Gaboor* varieties, respectively as shown in Table 1. The highest values in elastic modulus of pumpkin seed was attributed to Parallel plate method in *Hertz* theory while cylindrical indenter in *Boussinesq's* theory showed the lowest values. The low value for the *Boussinesq's* theory was predictable, since in this case the structural mechanics of the seed was changed by removing both ends of the specimen. Also in using of *Boussinesq's* theory, when the seed was compressed by the cylindrical indenter, a full contact area was immediately reached and the displacement was constant over the circular base of the cylinder. On the other hand, under the both parallel plates method the area of pressure was gradually increasing with load increasing. In agreement with these results, Khazaei (2002) reported highest values of elastic modulus of pea for Parallel plates tests than other existing methods in elasticity theory. In addition, from a materials-handling point of view, it is concluded that the methods employing whole specimens are to be preferred to the methods using cylindrical and flat specimens, because employing whole specimens is more representative of the

real application found in practice. These results also were found by many researches (Fridley *et al.*, 1968; Shelef and Mohsenin, 1969; Arnold and Roberts, 1969; Arnold and Mohsenin, 1971; Misra and Young, 1981; Jindal and Techasena, 1985; Bargale and Irudayaraj, 1995; Shitanda *et al.*, 2002). The values of elastic modulus of *Gaboor* variety were significantly higher than *Zaria* variety for all studied methods. These differences in elastic modulus could be the result of the individual cultivars properties and different environmental and growth conditions of cultivars (Table 1).

Table 1. Modulus of elasticity for pumpkin seed under uniaxial compression.

Variety	Theory used	Testing method	E (10 ⁵ Mpa)
Zaria	Hook's Law	Parallel plate- cylindrical specimens	71.4
Gaboor	Hook's Law	Parallel plate- cylindrical specimens	99.68
Zaria	Hertz	Parallel plate- whole specime	91.6
		Spherical Indenter- whole specimen	75.7
		Spherical Indenter- Flat specimen	65.8
Gaboor	Hertz	Parallel plate- whole specime	119.88
		Spherical Indenter- whole specimen	103.98
		Spherical Indenter- Flat specimen	94.08
Zaria	Boussinesq's	Cylindrical indenter - Flat specimens	61.15
Gaboor	Boussinesq's	Cylindrical indenter - Flat specimens	89.43

Selection the best theory for determination of elasticity modulus using pumpkin seed as a case study

Examination of the Equations (1)-(8) shows that, within the each range, the following relationships between force and deformation should be expected:

- (a) *Hook's Law* F= f (D) (straight line)
- (b) *Hertz theory* F= f (D)^{3/2} (curved line)
- (c) *Boussinesq's theory* F= f (D) (straight line)

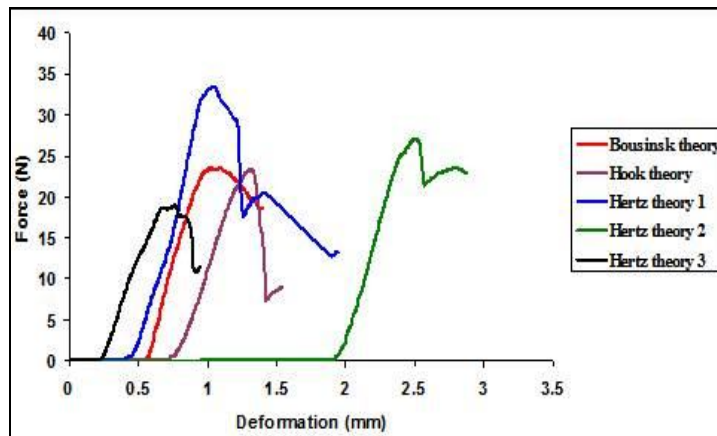

Fig 4. Force-deformation curves for pumpkin seed.

Some typical force-deformation curves obtained for *Zaria* variety of pumpkin seed (Figure 4). The curves which are obtained from *Hook's* Law and *Boussinesq* theory, are not straight, but they are less curved than curves that are on the basis of *Hertz* theory. According to above relationships (labeled b) Plotting curves 2 and 4 on log-log paper should produce straight lines with a slope of 1.5. It can be found from Fig. 4, a reasonable approximation to these theoretical and experimental curves often do not exactly lead to correspond. It seems to be one of the main factors causing the wide range of reported values for modulus of elasticity of one agricultural produce. The literature showed that many researchers have interpreted their force-deformation curves (Fridley *et al.*, 1968; Shelef and Mohsenin, 1969; Arnold and Roberts, 1969; Misra and Young, 1981; Jindal and Techasena, 1985; Khazaei, 2002; Shitanda *et al.*, 2002, Kiani *et al.*, 2009). The authors could not find any published work to recommend one of the existing theories as the best one for agricultural produce. Arnold and Roberts (1969) who applied *Hertz* theory to compress cubical samples of wheat revealed that to distinguish one theory as the more precise method to determine modulus elasticity of grain such as wheat is impossible. Shelf and Mohsenin (1969) also did not suggest any particular method for this purpose. In this study the obtained force-deformation curves for pumpkin seed are interpreted in several different ways to select best theory. A summary of these interpretations is presented in Table 2.

Table 2. Interpretations placed on force-deformation curve.

Number	Type of loading	Method for determining F and D Hertz theory
1	Parallel plate	Initial part of curve linearized. Force at linear limit
2	Parallel plate	Total curve used. Force at deformation = $1/2 D_T$
3	Spherical Indente	Initial part of curve linearized.
4	Spherical Indente	Force and deformation at point where F vs $D^{3/2}$ ceases to be linear. Use total curve
5	Parallel plate	Force and deformation from line tangent to initial part.
6	Spherical Indenter	Force and deformation from line tangent to initial part
7	Parallel plate	Use total curve. Force and deformation at linear limit Boussinesq's theory
8	Cylindrical Indenter	Force and deformation from slope of linear part of curve.

The variability of results obtained from these interpretations for *Zaria* variety of pumpkin seed is demonstrated in Table 3. The interpretation number 7 was lowest coefficient of variability percent. Considerably, according to Tables 2 and 3, several significant observations can be made as the methods of interpretation of the force-deformation curves which are based on the *Hertz* theory and which utilize the complete as prefer to those methods which linearize the initial part of the curve. Interpretation number 4 nearly conforms to the *Hertz* theory, but from a practical standpoint the method is much tedious and subjective in its application. The tedious aspect that it is necessary to plot the force-deformation curves in log-log form. The subjective nature of the method is evidenced by the log-log plots that did not have slopes of exactly 1.5 and hence the method has to be adapted to "fit" the experimental data. Since the scales are logarithmic, small errors in the measurement of forces and deformations near the origin that marked influence on the slope of the log-log plot thereby adding to the arbitrary nature associated with the selection of the point where F versus $D^{3/2}$ ceases to be linear. The authors contend that interpretation 2 and 6 are less subjective and easier to apply than interpretation 4. The subjective nature of these methods arises from the necessity of having to locate the "linear limit". However, if the linear limit is regarded as the point where the slope of the force-deformation curve begins to decrease then the point is reasonably well defined. On the basis of these comments the authors recommend that interpretations 2 and 7 be regarded as the preferred practical techniques, with interpretation 7 probably gave the best results.

Table 3. Modulus of elasticity of Zaria variety of pumpkin seed on the basis of interpretation of the force-deformation curves.

Sample number	Interpretation number-Table 2							
	1	2	3	4	5	6	7	8
1	99.3	73	76	71.8	62	54.2	91.2	61.2
2	99	71.9	75.8	72	61.8	55	91	61
3	98.6	73	75.8	71.9	63	53.4	90.8	62
4	98	73.2	75.1	72.1	61.1	53	92	61.8
5	98.3	73.6	75.9	72.8	63.4	53.6	91.6	61.6
6	98.4	73	76.1	71.6	62.1	55.1	91.4	61.7
7	99.8	72.6	75.3	72	61.8	54.7	91.8	62.3
8	98.4	72	75.4	72.3	62.4	54.6	90.4	61.9
9	99.1	71.8	75.9	71.6	61.9	55.2	91.8	62.1
10	98.1	72.1	75.2	71.7	63	53.7	91.1	62.4
11	98.9	72.5	74.9	72.1	63.4	53.2	91.9	62.4
12	99	73.8	74.7	72.3	62.5	55	91	62
13	98.8	72.4	76.1	71	63.8	54.9	91.8	61.8
14	98.9	72.9	75.7	72.9	61.6	54.6	90.9	62.3
15	99.5	72.7	75.6	72.4	62.5	53	91.5	62.5
16	99.4	73	74.8	72.6	61.7	55	91	62.7
17	98.6	73.2	75.8	73.1	63.1	54.3	91.6	61
18	99.2	73.1	76	71	63	54.7	91.8	61.8
19	99.4	73.1	74.5	72	62.9	55.1	91.4	62.1
20	98.5	72.3	74.8	71.6	61.8	53.6	91.5	63
Average (Mpa)	98.86	72.76	75.44	72.04	62.44	54.29	91.37	61.96
Coefficient of variability (%)	24	30	27	31	53	58	18	26

Since the initial part of the force-deformation curves for die loading are curved rather than straight, techniques based on the *Hertz* theory are preferred. Shelef and Mohsenin (1969) cemented on the shape of the initial part of the curve. They contended that small initial curvature was caused by some factors, such as smoothness of the indenter at the point of contact, full-contact area upon load pressure of air spaces. Many researchers also discussed that the *Hertz* theory is preferable to the *Boussinesq's* theory for obtaining data on elastic properties of fruits because (a) results compare more favorably with those predicted from theory, (b) the *Hertz* theory (parallel plate test) is more representative of the type of load application found in practice, and (c) test procedure is less critical (Fridley *et al.*, 1968; Arnold and Roberts, 1969; Khazaei, 2002; and Shitanda *et al.*, 2002). Furthermore, Khazaei (2002) found that applying *Boussinesq's* theory in compression test using indenter will lead to almost a nonlinear behavior of force-deformation curve in its elastic part.

The comparison of the two techniques utilizing the *Hertz* theory reveals that the one using parallel plate is preferable. In agreement with this result, Khazaei (2002) revealed that parallel plate is more suitable than spherical indenter because of good agreement between theoretical and experimental results of force deformation curve.

Poisson's ratio of agricultural produce

As it was mentioned in last parts, using of *Hertz* and *Boussinesq* theories for determination of elastic modulus is required to knowing *Poisson's ratio*. So, many researchers have studied *Poisson's ratio* for agricultural produce. In a study on wheat that was done by Shelef and Mohsenin (1969), *Poisson's ratio* was assumed 0.4. Arnold and Roberts (1966) investigated the effect of deformation and elastic modulus on *Poisson's ratio* of wheat. They revealed that variation of *Poisson's ratio* of wheat was 0.3 to 0.5. Kiani *et al.* (2009) obtained *Poisson's ratio* values from 0.322 to 0.267 and from 0.406 to 0.340 for moisture levels ranging from 5 to 15%, for *Goli* and *Akhtar* varieties of red bean, respectively. Many researchers have also assumed a value of 0.4 for *Poisson's ratio* of agricultural produce (Fridley *et al.*, 1968; Misra and Young, 1981; Jindal and Techasena, 1985; Bargale and Irudayaraj, 1995; Khazaei, 2002). So, in this study a value of 0.4 for *Poisson's ratio* of pumpkin seed was used in Eq (2) to (6).

Conclusion

It is shown that there are several possible methods based on the elasticity theory, which can be employed to determine a modulus of elasticity of agricultural produce. Considering the obtained values for modulus of the elasticity of pumpkin seed on the basis of these methods, the highest values in elastic modulus of pumpkin seed attributed to parallel plate method in *Hertz* theory while cylindrical indenter in *Boussinesq's* theory showed the lowest values. However, because of the complexity of the produce being considered, it is virtually impossible to ascertain which of the methods produces the most reliable results. So, to reduce the variability which currently exists in results, in this study the obtained force-deformation curves for pumpkin seed were interpreted in several different ways to select the best theory. As indicated when discussing the testing of pumpkin seed, the methods of interpretation of the force-deformation curves which are based on the *Hertz* theory and utilize the complete curve, are to be preferred to those methods which "linearize" the initial part of the curve. While interpretation number 4 most nearly conforms to the *Hertz* theory, as a practical standpoint the method is more tedious and

subjective in its application. Therefore, interpretations 2 and 7 are preferred practical techniques, with interpretation 7 probably giving the better results. Also, the obtained results revealed that parallel plate is more suitable than spherical indenter because of good agreement between theoretical and experimental results of force deformation curve. In addition, from a materials-handling point of view, it is felt the methods employing whole specimens are to be preferred to the methods using cylindrical and flat specimens, because employing whole specimens is more representative of the real application found in practice.

Acknowledgments

The authors would like to thank the Ferdowsi University of Mashhad for providing the laboratory facilities and financial support through the project No. of 15740/2.

References

- Altuntas, E. Ozgoz, E and Taser, O.F. (2005). Some physical properties of fenugreek (*Trigonella foenum-graceum* L.) seeds. *Journal of Food Engineering* 71: 37–43.
- Arnold, P.C and Robert, A.W. (1966). Stress distribution in loaded wheat grains. *Journal of Agricultural Engineering Research* 11: 38-43.
- Arnold, P.C and Robert, A.W. (1969). Fundamental aspects of load-deformation behavior of wheat grains. *Transaction of the ASAE* 18: 104-108.
- Arnold, P.C and Mohsenin, N.N. (1971). Proposed techniques for axial compression tests on intact agricultural products of convex shape. *Transaction of the ASAE* 14: 78-83.
- Balastreire, L.A. Herum, F.L. Stevens, K.K and Blaisdell, J.L. (1982). Fracture of corn endosperm in bending: Part 1. Fracture parameters. *Transaction of the ASAE* 25: 1057-1062.
- Bargale, P.C. Irudayaraj, J.M and Marquis, B. (1994). Some mechanical properties and stress relaxation characteristics of lentils. *Journal of Canadian Agriculture Engineering* 36: 247-254.
- Bargale, P.C and Irudayaraj, J.M. (1995). Mechanical strength and rheological behavior of barely kernels. *International Journal of Food Science and Technology* 30: 609-623.
- Boussinesq, J. (1885). *Applications des potentiels a l'etude de l'equilibre et du mouvement des solides elastiques*. Paris.
- Burubai, W. Amula, E. Davies, R.M. Etekpe, G and Daworiye, S.P. (2008). Determination of Poisson's ratio and elastic modulus of African nutmeg (*Monodora myristica*). *International Agrophysics* 22: 99-102.
- Crandall, S.H. Dahl, N.C and Lardner, J.T. (1978). *Introduction to the mechanics of solids*. 2nd Revised and Updated Edition, Tokyo. McGraw-Hill.
- Coskun, M.B. Yalcin, I and Ozarslan, C. (2005). Physical properties of sweet corn seed (*Zea mays saccharata* Sturt.). *Journal of Food Engineering* 74: 523–528.
- Fridley, R.B. Bradley, R.A. Rumsey, J.W and Adrian, P.A. (1968). Some aspects of elastic behavior of selected fruits. *Transaction of the ASAE* 11: 46-49.
- Hertz, H. (1986). *Miscellaneous paper*. MacMillan and Company, New York. 1986.

- Hicsasmaz, Z. and Rizvi, S.S.H. (2005). Effect of size and shape on modulus of deformability. *Journal of food engineering* 38: 431-435.
- Jindal, V.K and Techasena, O. (1985). Compression test for measuring the firmness of potatoes. *Transaction of the ASAE* 11: 85-92.
- Khazaei, J. (2002). Determination of force required to pea pod harvesting and mechanical resistance to impact. Ph.D Thesis, Faculty of Biosystem Engineering, University of Tehran, Karaj, Iran.
- Khodabakhshian, R. Emadi, B. Abbaspour Fard, M.H and Saiedirad, M.H. (2010). Mechanical Properties of Sunflower Seed and its Kernel, Azargol Variety as a Case Study, under Compressive Loading. *Journal of Agricultural Science and Technology* 2: 34-41.
- Kiani, M. Maghsoudi, H and Minaei, S. (2009). Determination of Poisson's ratio and Young's modulus of red bean grains. *Journal of Food Process Engineering* 10: 1745-1756.
- Kosma, A and Cunningham, H. (1962). Tables for calculating the compressive surface stresses and deflections in the contact of two solid elastic bodies whose principle planes of curvature do not coincide. *Journal of Industrial Mathematics* 12: 31-40.
- Levin, J.H. Hall, C.W and Deshmukh, A.P. (1959). Physical Treatments and cracking of sweet cherries. *Quart. Bul. of the Mich. Ag. Exp. Sta* 42: 133-138.
- Misra, R.N and Young, J.H. (1981). A model for predicting the effect of moisture content on the modulus of elasticity of soybeans. *Transaction of the ASAE* 24: 1338-1241.
- Mohsenin, N.N. (1986). *Physical Properties of Plant and Animal Materials*. 2nd Revised and Updated Edition. Gordon and Breach Science Publishers, New York.
- Morrow, C.T. and Mohsenin, N.N. (1966). Consideration of selected agricultural products as viscoelastic materials. *Journal of Food Science* 31: 686-698.
- Shelef, L and Mohsenin, N.N. (1967). Evaluation of the modulus of elasticity of wheat grains. *Cereal Chem* 44: 392-402.
- Shelef, L and Mohsenin, N.N. (1969). Effect of moisture content on mechanical properties of shelled corn. *Cereal Chem* 46: 242-253.
- Shitanda, D. Nishiyama, Y and Koide, S. (2002). Compressive strength properties of rough rice considering variation of contact area. *Journal of food engineering* 53: 53-58.
- Shpolyanskaya, A.L. (1952). Structural mechanical properties of wheat grain. *Olloid Journal (USSR)* 14: 137-148.
- Timbers, G.E. Stately, L.M and Waston, E.L. (1965). Determining Modulus of Elasticity in Agricultural Products by Loaded Plungers. *Agriculture Engineering Journal* 46: 274-275.
- Timoshenko, S. and Goddier, L.N. (1951). *Theory of elasticity*. McGraw-Hill book company, Inc, New York.

(Received 31 May 2011; accepted 1 October 2011)