

PRE-PROOF FILE

Providing a Practical Method for Automatic Start-Up of Reactive Distillation Column using Decentralized Control of CVs Trajectory based on Residue Curve Maps (RCM) Analysis: The Methyl Acetate Case

Vahidi Ferdowsi, Maissam; Fanaei, Mohammad Ali^{+}*

Department of Chemical Engineering, Faculty of Engineering, Ferdowsi University of Mashhad, Mashhad, I.R. IRAN

Karimpour, Ali

Department of Electrical Engineering, Faculty of Engineering, Ferdowsi University of Mashhad, Mashhad, I.R. IRAN

ABSTRACT: *The primary purpose of this feasibility study is to use an appropriate decentralized control configuration (based on PID controllers) to automatically navigate the startup trajectory of a reactive distillation column in the presence of azeotropic points. The purpose of this article is to show how a conceptual understanding of the reactive residual curve map (R-RCM) may be utilized to define a trajectory for directing the control variables during startup. The results demonstrate that steering the startup operation using a two-point temperature control structure with the feed rate of the reactants specified as the control manipulator is more efficient than other structures. Examining the various startup strategies shows several steady-state conditions at the end of the start-up time. This is because only a unique approach will achieve the desired steady-state condition. According to the findings, the controller tuning parameters play a significant impact in steering the startup trajectory. For this case study, the gain and integral time values for both controllers should be approximately one-third and three times, respectively, of the values found under normal operating conditions.*

KEYWORDS: *Dynamic simulation, Reactive distillation, Methyl acetate, Startup, Residue curve maps*

INTRODUCTION

Acetic acid esterification with methanol is one of the most well-known processes used to produce methyl acetate. Conventional distillation is unable to yield a high purity product because of the methyl acetate-methanol and methyl acetate-water azeotropic points, as well as the

proximity of the azeotropic point temperature to the methyl acetate boiling point. Reactive distillation (RD), pressure swing distillation, and extractive distillation are some of the distillation methods that have been taken into consideration due to the rising demand for high-quality

** To whom correspondence should be addressed.*

+E-mail address: fanaei@um.ac.ir

1021-9986/2023/11/0000-0000

13/\$/6.03

methyl acetate. Extractive distillation for the esterification of acetic acid with methanol is more frequently used in the industry than other processes, especially on smaller scales, because it is less complex and simpler to understand than other processes. However, using the reactive distillation method will require fewer pieces of equipment and result in less mass and energy loss. This surprisingly shows that business owners favor straightforward methods over economical ones. Because they can now manage production independently and are less dependent on experts in the field. However, this suggests that if the control of reactive distillation processes can be made simpler, the economic benefits of the reactive distillation method will make it more useful.

The startup operation, which has been taken into consideration by researchers in recent years, is one of the main challenges in the reactive distillation process. The startup procedure is the most difficult process in operational activities due to the simultaneous changes in several dependent process variables. Reactive distillation combines a chemical reaction with thermal separation in a single column, making it more challenging to start up than traditional distillation processes. One of the other challenges is the deviation of operating conditions from favorable steady-state conditions, such as azeotrope production points during reactive distillation column startup. Since the late 1990s, most of the research in this field has moved towards the use of techniques such as model predictive control (MPC) due to the nonlinear behavior of reactive distillation columns and also due to the interest of researchers in expanding computer control applications. Baldon's studies in 1997, which were able to decrease the startup operation time using the dynamic matrix control (DMC) method, are among the earliest works done in the field of automatic control of the operation of reactive distillation columns [1]. Using dynamic simulations, Scena and Benz demonstrated in 1998 how a startup policy can improve or degrade the process as a whole. Additionally, they demonstrated how picking the incorrect approach to attain steady state could put the column in operating conditions that are wholly inappropriate [2]. The findings of their investigation into the ethylene glycol instance from 2003 show that multiple steady states can occur during reactive distillation column startup [3]. In 2004, *Reepmeyer et al.* proposed strategies for optimal startup of RD columns using computer control.

They introduced a function for optimal control called the MX-function. The function is the sum of differences between the actual composition of the top product and the steady state composition of all components. They showed if the MX-function is permanently below 0.001, the desired steady state is defined to be reached [4,5]. Recent years have seen consideration of the use of computer control to automate reactive distillation column startup, thus *Engell et al.* in 2018 continued their research in this area utilizing the dynamic real-time optimization (D-RTO) technique [6]. As can be seen, valuable work has been done in the field of optimal control of startup operations using computer control, but due to the high cost of initial investment to equip the process with a centralized control system, many of these methods are limited to the knowledge frontier and have been less welcomed by industry owners. With this description, the main goal of this research is to find a way to avoid using advanced process control systems and instead use a decentralized control system (PID) to direct the startup operation of the reactive distillation column in the presence of azeotrope points.

Given the above, the first step in this study is to examine the control configurations to select an appropriate structure. For this target, all the proposed configurations for double feed RD columns were evaluated through dynamic simulation. In the last twenty years, several articles have been published on the control structures of reactive distillation columns. Meanwhile, the studies of Luyben and Kaistha have received more attention than similar cases in this research [7-12].

In 2000, *Luyben et al.* explored the closed-loop control of a reactive distillation column in which two products were produced in a single column and stoichiometric amounts of fresh feeds were desired. In this work, Luyben evaluated six alternative control structures through rigorous dynamic simulation [7].

Luyben et al. continued their studies in 2002 with a focus on the methyl acetate case. Their investigation shows that a two-temperature control structure is effective when the system is overdesigned in terms of the number of reactive trays, holdup, and/or catalyst load [8].

Kaistha et al. conducted a similar study in 2007 focusing on methyl acetate case, which showed that control of (difference of two reactive tray temperature) resulted in a significant improvement in control system robustness in terms of its ability to control high production rates [9].

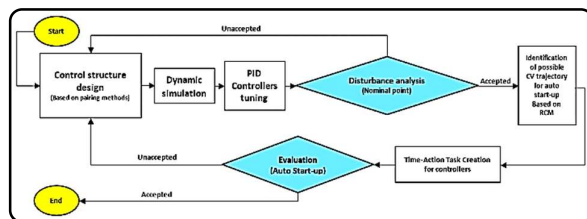

Fig. 1: Research methodology diagram

In 2008, they also evaluated the effect of changing feed tray locations (to save energy) on the controllability of double feed reactive distillation (RD) columns for two case studies [10]. They showed that for the methyl acetate case, heat integration by altering the feed locations entailed no loss in controllability using two-point temperature inferential control.

In the same year, Kaistha and Kumar investigated the effect of steady-state multiplicity on the control of an industrial-scale reactive methyl acetate distillation column [11]. Simulation results in this case showed that at a fixed reflux rate, some of the reactive trays' temperatures exhibited input and output multiplicity with respect to all three inputs; reboiler duty, methanol flow rate, and acetic acid flow rate.

In 2009, Kaistha *et al.* continued their studies on the evaluation of ratio control schemes in a two temperature control structure (the methyl acetate reactive distillation column case) [12]. In this study, the closed loop performance of a two-temperature control structure with three different ratio control schemes was evaluated for a methyl acetate reactive distillation column design. The results showed that keeping the two fresh feeds in the same ratio did not improve control performance or robustness.

Although reviewing these articles helps a lot in choosing the startup procedure and the control structure, it seems that due to the differences between the views of this study and similar cases, there is a need to review the control configurations this time with the aim of RD startup. On the other hand, to introduce the automatic startup procedure (based on a PID controller) of the reactive distillation column, the reactive residue curve map has been analyzed, which is described in the following sections.

RESEARCH METHODOLOGY

Fig. 1 indicates the research methodology utilized in this study. The use of the R-RCM (reactive-residue curve maps) analysis method to determine the trajectory of control

variables during the startup operation from the starting point to the nominal point is innovative here. It should be noted that the most important constraint in this process is to avoid the production of undesirable products and azeotrope formation during the startup procedure. What has been mentioned is the first and most important step in this research, which consists of the three stages listed below.

- Identification of control variables trajectory for automatic startup based on evaluation of R-RCM
- Evaluation of control structures performance to direct the control variables trajectory during the startup time through the dynamic simulation
- Control parameters tuning and gain scheduling

THEORY

As previously mentioned, startup process is one of the most significant operational challenges. Typically, state variables are manually directed from startup initial values to operational normal conditions. However, the hard nonlinear behavior of some processes during startup makes manual startup difficult. Reactive distillation columns are one of the most common processes that have non-linear behavior during startup operations. In addition to the nonlinear behavior of reactive distillation columns, the presence of azeotrope points can complicate the startup process. In other words, if the conditions for azeotrope formation in reactive distillation columns are achieved at startup time, the trajectory of state variables will automatically move towards azeotrope formation, an unwanted steady-state condition. What has been described shows that the startup operation for these processes requires the exact steering of control variables. To determine the best startup path, first must be investigated the reason for the deviation of the desired operational conditions (relatively pure product) to undesired conditions (azeotrope formation).

In this study, the use of R-RCM three-dimensional topology to check and determine the start-up trajectory has been evaluated. Residue curves start at the composition of a feed and then move to pure components or azeotropic points with higher temperatures (isobaric condition) or lower vapor pressures (isothermal condition). Azeotropic points can create so called distillation regions separated by border lines from other regions. If the composition of a feed lies inside a specific region a residue curve cannot cross a border line and stays

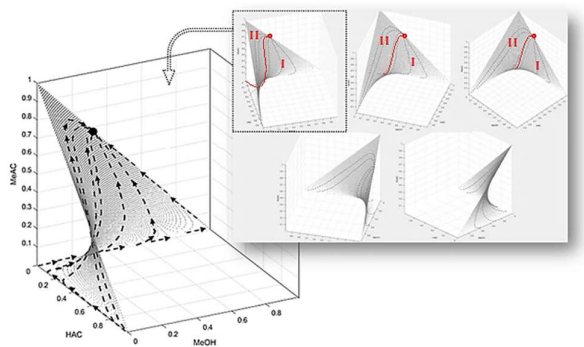

Fig. 2: Equilibrium plane and Reactive RCM (Dash lines with arrows) for the mixture of MeAc, MeOH, water, and HAc at atmospheric pressure.

in its initial region. This means that for a conventional distillation tower with an azeotropic point between two products, it is impossible to obtain pure components at the bottom and head of the column. But in a reactive distillation column, the path of the residual curves, known as R-RCM, is changed by the chemical reaction and placed on the equilibrium plane. Creating this plane through a chemical reaction removes the limitations of the distillation boundaries and allows for a purer separation.

According to the case study (methyl acetate production), Fig. 2 represents the equilibrium plane and R-RCM for a quaternary mixture of methyl acetate, methanol, water, and acetic acid with an equilibrium constant $K = 5.2$. This map was created by projecting the two-dimensional topology from Song's article [16]. As shown in Fig. 2, both the methyl acetate and water products are on the chemical equilibrium plane; thus, reactive distillation can theoretically be used to separate them. Because the chemical reaction is limited by equilibrium, temperature changes along the reactive distillation column affect the equilibrium constant and the rate of reaction. This means that if the temperature trajectory is not controlled during the start-up operation, the shape of the equilibrium plane will change. This shows that it will be possible to deviate the startup trajectory in the direction of azeotrope production.

Another factor that enables the azeotrope formation condition is the availability of reaction-free trays. In reactive distillation columns, there are typically two other sections, rectifying and stripping, that are free of catalyst and operate in the same manner as conventional distillation columns. Because it is not possible to cross the distillation

boundaries in non-reactive sections, their input feed must be within the desired distillation region. In other words, the trajectory of the control variables during startup should be such that the path of the non-reactive sections' working points (composition) stays away from the azeotrope points. According to the RCM curves (Fig. 2), if the startup operation is started with pure methanol, the composition of the components in the rectifying section can proceed towards the azeotrope point. This is due to the existence of an azeotrope point between methanol and methyl acetate, which makes achieving methyl acetate as a saddle point in a non-reactive section difficult.

Evaluating the distillation zones is another method to find the cause of the operational conditions deviating from the desired condition to the azeotrope formation state during startup. On the equilibrium reaction plane, the presence of the water component as a saddle node and the Azeotropic point as an unstable node results in the creation of two separate distillation regions (Fig. 2). In 2023, Huss et al. demonstrated that crossing the distillation boundary to obtain pure methyl acetate using a single feed system is not possible. They also demonstrated that methyl acetate may be placed in the product region if two feeds are employed and both feeds enter the reactive distillation column at the same molar flow rate (equimolar) [19]. With this description, it is simple to conclude that the absence of molar balance of the components in the reactive section is the cause of a deviation from the desired conditions and the failure to produce pure methyl acetate during the start-up time. On the other hand, it is not possible to begin the column startup with the initial amounts of pure acetic acid for two reasons. One reason is that acids are corrosive at high temperatures, and the more important reason is that acetic acid has a high boiling point. In other words, because acetic acid has a higher boiling temperature than other reactants, methanol will evaporate as soon as it enters the column and will not be able to fall into the lower reactive trays. If both feeds are not entered in pure form, the components of methyl acetate and water will not be inserted in pure form in the product region. Since the water component and the azeotrope point are designated the saddle node and the unstable node, respectively, two distillation zones will form. Only when acetic acid is in pure form may methyl acetate be placed in the product region by drawing the direct and indirect sequence lines. This holds true for methanol in the second distillation zone

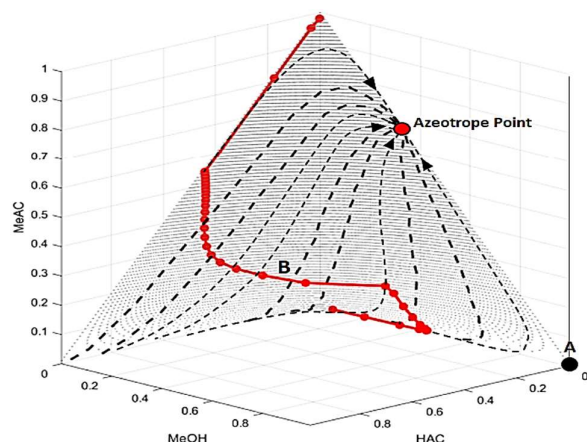

Fig. 3: Steady-State composition profile (Line B, solid line with marker "●") and start point (A) of startup operation.

as well. Huss *et al.* investigated the use of impure feeds in 2003 and demonstrated that access to pure methyl acetate would be feasible under certain situations (equimolar) [19]. According to what has been said, the best solution is to fill the column, sump, and reflux drum with pure methanol, followed by an automatic startup using an efficient control structure based on a reliable control variable trajectory.

As can be seen in Fig. 2, two distillation regions (I, II) appear on the two sides of the red line. If the startup operation begins with the pure methanol, point A (shown in Fig. 3) is the starting point for all trays, and the final goal is to reach line B (solid line with marker "●") according to the column's composition profile. Line B represents the steady-state conditions at the end of the startup operation. This composition profile is obtained through steady-state simulation, which is further explained in the following section.

The main challenge in this solution is to find a trajectory for the control variables (Trays temperature) that places their position in a zone that allows access to the saddle point for the rectifying section of the column. The composition of the rectifying section's trays will automatically go from point A to the azeotrope point based on the path of residue curves (Fig. 3). Therefore, the reactive section's state variables path should be directed so that the composition trajectory of the rectifying section is diverted towards acetic acid.

Fig. 4 represents the composition trajectories of the rectifying section bottom tray from beginning of the startup operation to the steady state condition. Although achieving this trajectory is unrealistic and highly ideal, it appears that moving along this path or following this

Table 1: Major simulation requirements of case study [13]

Description	value
Total no. of trays including reboiler	39
No. of trays	
Stripping section (NS)	3
Reactive section (NRX)	34
Rectifying section (NR)	1
Reactive trays	2-35
Acetic acid feed tray	3
Alcohol feed tray	26
Feed flowrate (kmol/h)	
Acid	0.500
Alcohol	0.500
Product flowrate (kmol/h)	
Top	0.5035
Bottom	0.4965
Products purity (mole fraction)	
MeAc	0.98
Water	0.98
Reflux Ratio	1.97
Pressure (atm)	
Top	1.1
Column pressure drop	0.2

pattern during the startup operation will be most compatible with the equilibrium plane. In the following section, the performance of the proposed startup trajectory has been evaluated using dynamic simulation.

SELECTION OF CONTROL STRUCTURE FOR USE IN AUTOMATIC STARTUP THROUGH DYNAMIC SIMULATION

The selected case study is based on a real unit first introduced by Yu *et al.* Although, according to them, the process information presented cannot be found elsewhere in the open literature, it has been used here because it was later used by many researchers [13]. The structure used in this case is a split-feed type in which both streams are fed to a column with an equimolar feed ratio (FR = 1). The light reactant (Methanol, "MeOH") enters on Tray 26 (trays numbers are counted from top to bottom) and the heavy reactant (Acetic Acid, "HAc") enters on Tray 3. It must be noted these two trays lie inside the reactive zone containing catalyst Amberlyst 15. Fig. 5 shows the case study flowsheet, and Table 1 lists the major simulation requirements for this column.

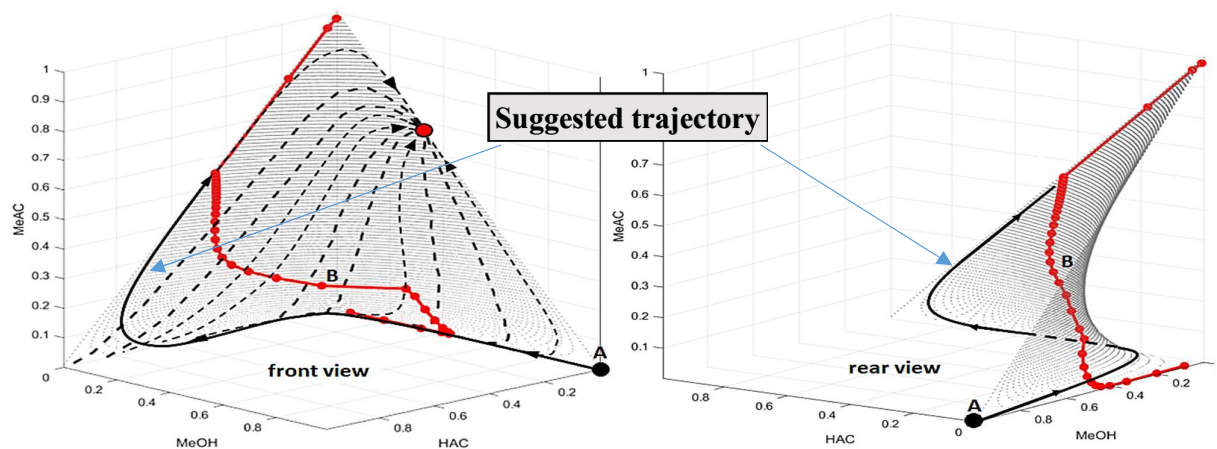

Fig. 4: Suggested trajectory for the composition of the column's rectifying section.

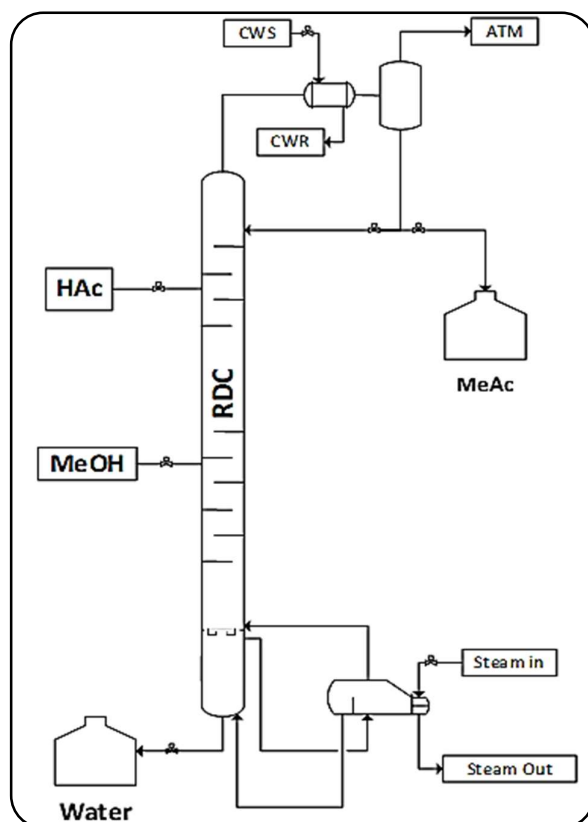

Fig. 5: Process schematic of case study (methyl acetate RDC)

The steady-state of the reactive distillation column is simulated using Aspen PLUS, and the dynamic simulation is built using Aspen PLUS Dynamic V11. *Yu et al.* used the UNIQUAC model for activity coefficients to calculate the non-ideal vapor-liquid equilibrium (VLE) of this quaternary system [13]. Other researchers, such as

Luyben, Kaistha, Popken, and Handogo, have also used the model mentioned for this system [8,9,14,15].

Here, in addition to the equilibrium data of binary mixtures, the VLE experimental data of ternary and quaternary mixtures is used to estimate the model parameters using the regression method. According to this description, the results obtained in this work will be more credible due to the larger database compared to *Yu et al.*'s work, as well as the inclusion of VLE experimental data of ternary and quaternary mixtures in the model regression. Table 2 shows all of the model prediction results, as well as the VLE experimental data references and modified parameters.

Acetic acid (HAc) esterification with methanol (MeOH) is represented by the following reaction (Eq. (1)):

$$\text{CH}_3\text{COOH} + \text{CH}_3\text{OH} \leftrightarrow \text{CH}_3\text{COOCH}_3 + \text{H}_2\text{O} \quad (1)$$

In this process, Amberlyst 15 is used as a catalyst, which is an ion exchange resin. It should be noted that, based on the function of water inhibition, the provided kinetic models for the esterification reaction in the presence of Amberlyst 15 catalyst have been developed. *Ganesh et al.* (2011) explored the inhibitory effect in depth. They demonstrated that there is an inhibiting impact of water in the presence of low quantities of water, and that when water production increases, this role of water disappears [20]. The reaction kinetic and its parameters are listed in Table 3 [14].

Fig. 6 shows the mole fraction profiles of the components estimated by the steady state simulation along the column. The slight difference observed between the profiles obtained in this study and the results published by *Yu et al.* appears to be the result of this work's modification of the thermodynamic model.

Table 2: VLE experimental data, UNIQUAC model modified parameters and validation

Vapor- Liquid Equilibrium experimental data										Reference
Methanol - Acetic acid										Sawlstowski [15]
Methyl acetate - Acetic acid										
Methanol - Water - Acetic Acid										
Methyl acetate - Methanol - Acetic acid										
Methyl acetate - water - Acetic acid										
Methyl Acetate - Methanol - Water - Acetic Acid										
Methyl acetate - Methanol										V.H. Álvarez [16]
Methyl acetate - Water										
Methanol - Water										
Methyl acetate - Methanol										Jialin Cai [17]
Methyl acetate - Methanol										Isamu Nagata [18]
UNIQUAC Activity Coefficient Model Parameters for esterification of the acetic acid with MeOH										
Comp. i	Comp. j	a_{ij}	a_{ji}	b_{ij}	b_{ji}	c_{ij}	c_{ji}	d_{ij}	d_{ji}	
MeOH	HAc	0.2148	-8.846	-81.01	-6008.894	0.08189	0.06647	0.00178	0.05728	
Water	MeOH	1.485	7.7407	-9255	-1169.683	8.21072	1.41065	-0.0678	-0.0347	
MeOH	MeAc	1.145	30.808	-1285	-7027.698	0.36645	5.69626	0.0031	-0.1324	
Water	MeAc	-49.84	-6.347	9584.5	2309.286	-0.30405	-3.16536	0.06837	0.05039	
Water	HAc	-32.3	9.824	11522	3298.606	-5.38043	-15.8715	0.09035	0.1892	
MeAc	HAc	-5.031	77.741	5203.8	13251.093	-5.54782	-29.3304	0.06651	0.15312	
Estimated Azeotrope values evaluation										
Compounds	Type	Mole. %								
		Experimental	Yu et al. [13]	This work						
MeAc - Methanol	Azeotrope (Base of MeAc)	66.59	0.6724	0.6930						
MeAc - Water	Azeotrope (Base of MeAc)	92	0.8960	0.9163						
HAc - Water	Azeotrope (Base of Water)	Not exist	0.8743	Not exist						

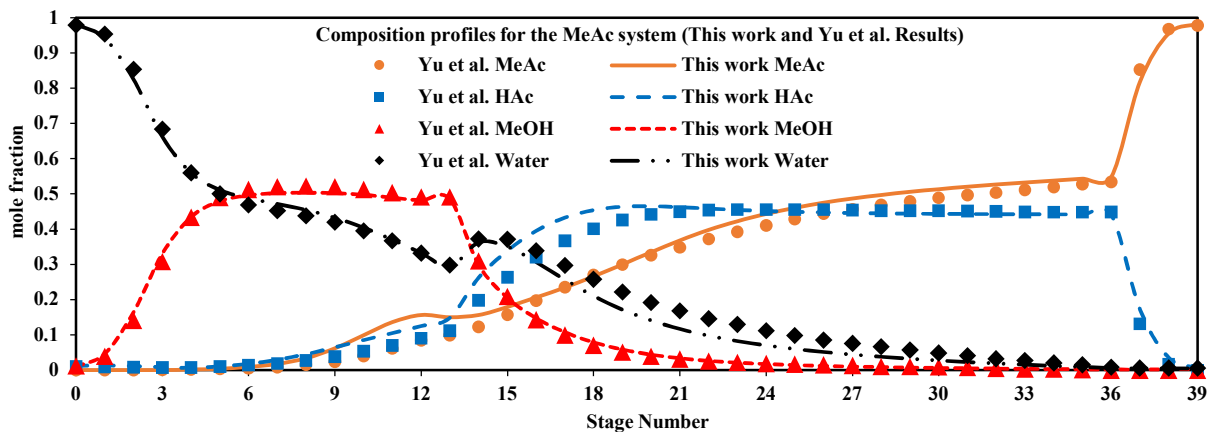

Fig. 6: Composition profiles resulting from the S.S simulation in this work and the simulation results of Yu et al. [13]

Following the steady-state simulation, a suitable control structure should be chosen, and the proposed startup

procedure should then be evaluated using dynamic simulation. As previously stated, the selected control

Table 3: Kinetic Equation for HAc esterification [14]

Pseudo homogeneous model, activities by UNIQUAC
$r = m_{\text{cat}} (k_f a_{\text{HAc}} a_{\text{MeOH}} - k_b a_{\text{MeAc}} a_{\text{water}})$
$k_f = 2.961 \times 10^4 \exp\left(\frac{-49190}{RT}\right)$
$k_b = 1.348 \times 10^6 \exp\left(\frac{-69230}{RT}\right)$
r : kmole/(kg _{cat} s)
T : Kelvin

structure should be capable of automatically tracking the startup trajectory as well as controlling the normal operating conditions. Given that the most important goal in this study is to provide a practical and industrial solution, it seems that the best choice is to use temperature inferential control structures. A control structure's performance under steady-state conditions differs significantly from its performance under startup conditions. However, a combined strategy was employed in this work to establish a suitable structure to direct the operation of the column start-up. The column control pairing for two conventional control structures was determined first, based on steady-state criterion such as slope criterion, sensitivity criterion, and SVD criterion, and then, with a large change in the set points, the performance of the control structures was evaluated in the face of tracking them.

Examination of the singular value decomposition (SVD) of the steady-state gain matrix and sensitivity criterion show that two dual temperature control structures can be developed from steady state sensitivity analysis. It should be noted that the results of choosing the tray for temperature control were the same in both methods. In the first control structure, CS1, flow rates of acetic acid and methanol, respectively, control the most sensitive reactive (T30) and stripping (T38) tray temperatures. In the second control structure, CS2, the reboiler duty controls a sensitive reactive tray temperature (T19), with methanol controlling a sensitive stripping tray temperature (T38), as in CS1. A schematic of the two control structures is shown in Fig. 7.

The ability of a control structure to track set points allows it to handle startup operations automatically. Therefore, the ability of temperature controllers to track their set points has been evaluated in this study in order to select an effective control structure.

The results (not presented here) have shown that for a 20% increase in production rate, the controlled outputs

of sensitive reactive tray temperature, based on CS2 are returned to their set points in just over 200 minutes. This is as a result of the tray temperatures' faster dynamics to the reboiler duty. In contrast, changes in the flow of fresh acetic acid (under CS1) are responded very slowly by tray liquid hydraulic lags.

But, the dynamic simulation results showed that in the CS2 control structure, controller action is "wrong" in the face of a 20% decrease in production rate. It should be noted that the "wrong action" in the CS2 type structure is rooted in the phenomenon of "input multiplicity," which is not discussed in this article. So, given this description, the CS2 control structure is probably not the best choice for startup operation. This is despite the fact that the structure of the CS1 type has produced better results in set point tracking tests. Consequently, only CS1 control structure has been examined in the following section.

AUTOMATIC CONTROL OF STARTUP TRAJECTORY USING CS1 CONTROL STRUCTURE

As previously stated, the column, sump, and reflux drum are initially filled with pure methanol. Additional information about the startup operation's initial conditions is provided below:

- All process inlet and outlet stream valves are closed. In other words, Reflux ratio controller, sump level controller and temperature controllers of trays 30 and 38 are in manual mode and their control valves are closed.
- The reflux drum level controller is in automatic mode and its set point is considered equal to the steady state value (45%).
- The pressure controller is in automatic mode and its set point is considered equal to the steady state value (1.0132 bar).
- Throughout the whole startup time, the reboiler duty value is taken to be constant and equal to the steady state value (0.02766 GJ/hr).

Several startup procedures were investigated based on these initial conditions. Although the temperatures of trays 30 and 38 as control variables are kept at 76.19 and 100.34 degrees Celsius at the end of the startup time, the results showed that there is a possibility of three steady-state conditions (Fig. 8).

In other words, the phenomenon of input multiplicity creates three different steady-state conditions in the presence of two same inputs (temperatures of trays 30 and 38). To achieve the desired steady-state condition as described

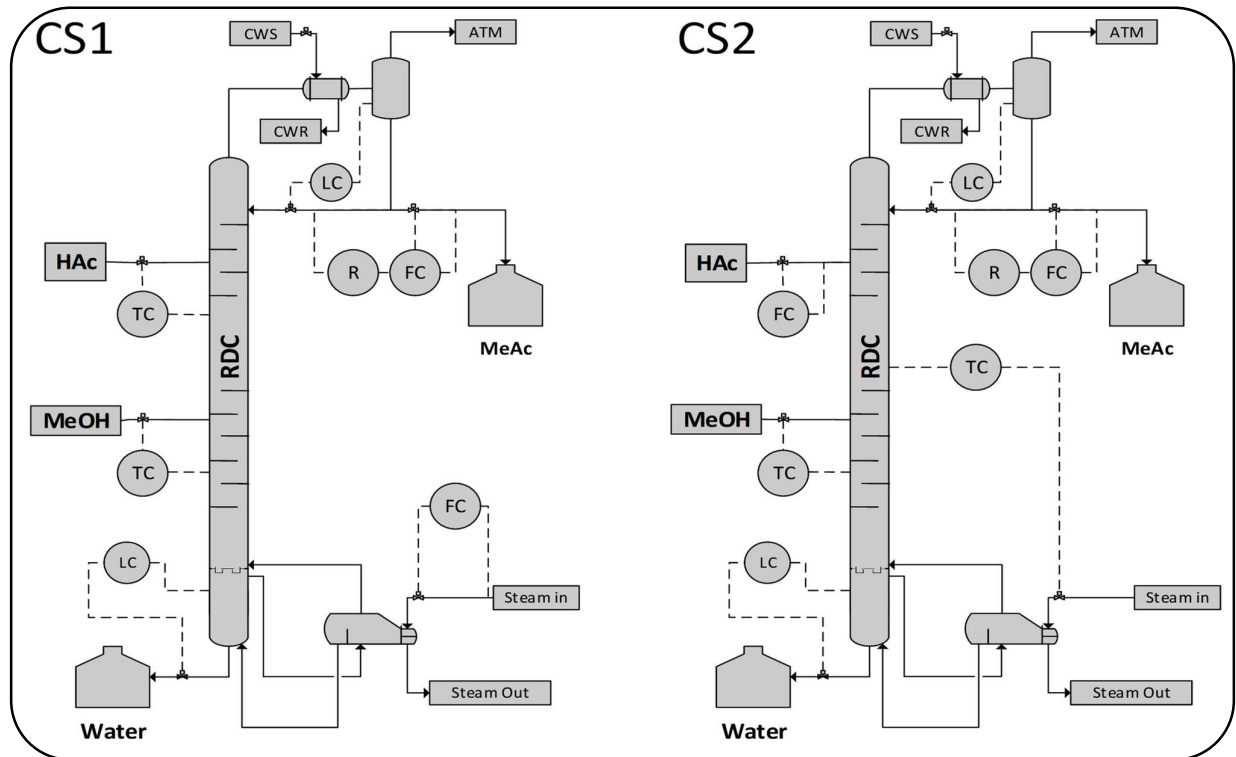

Fig. 7: Selected control structures, CS1 and CS2

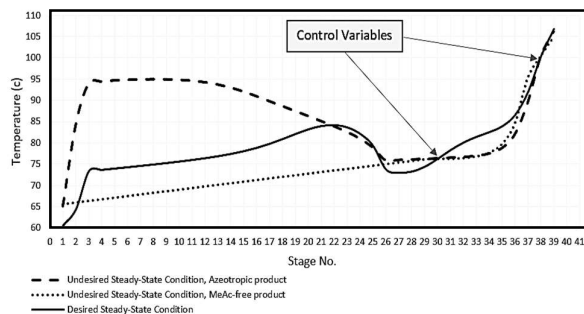

Fig. 8: Temperature profiles of three possible steady-state conditions at the end of the startup time.

In the theory section, controllers should be programmed with the goal of tracking the suggested trajectory (Fig. 4). After an evaluation of the startup's various trajectories, the start-up steps can be clearly directed based on shown in Table 4.

According to this procedure, the desired rectifying stage trajectory is obtained with a slight difference and a significant peak, resulting in the desired steady-state condition at the end of the startup time (Fig. 9). In order for the temperatures of trays 30 and 38 to be within the nominal temperature range, it is necessary to correct the initial temperature profile of the column by producing methyl acetate

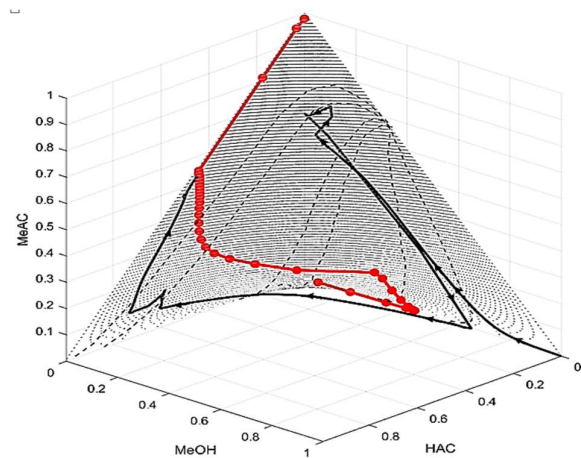

Fig. 9: Simulated composition trajectory of rectifying section tray (lines with arrows) during the startup operation based on CS1 control structure.

at the beginning of the startup. This causes some methyl acetate to be produced in the opposite direction of the suggested trajectory. Finally, at the appropriate time, by opening the product valve at the top of the column and emptying methyl acetate, the composition of the components of the rectifying section is placed on the desired trajectory.

Table 4: Suggested start-up steps based on dynamic simulation results.

Start by filling the column with pure methanol by observing the following initial conditions:					
Step No.	Controller name	Controller Mode	Controller Output	Controller Setpoint	Description
Initial Condition	Reflux ratio controller	Manual	0	---	Top product valve is close
	Sump level controller	Manual	0	---	Bottom product valve is close
	Temperature controller of tray 30	Manual	0	---	Acetic Acid feed valve is close
	Temperature controller of tray 38	Manual	0	---	Methanol feed valve is close
	Reflux drum level controller	Auto	---	45%	Reflux stream valve is control manipulator
	Condenser pressure controller	Auto	---	1 atm	Vent stream valve is control manipulator
	Reboiler duty controller	Manual	0.02766 GJ/hr	---	Duty value is constant
Wait for the temperature profile of the column filled with boiling pure methanol to achieve steady state. Then, The controllers' associated values are modified using the steps below:					
1	Temperature controller of tray 30	Switch to Auto	---	60 °C	Acetic Acid feed valve will be open*
2	Temperature controller of tray 38	Switch to Auto	---	100 °C	Methanol feed valve will be open
Wait for the Tray 30's temperature is achieves to 64°C. Then, The controllers' associated values are modified using the steps below:					
3	Reflux ratio controller	Switch to Cascade	---	---	Reflux ratio: 1.966
4	Sump level controller	Switch to Auto	---	15%	Bottom product valve will be open
5	Temperature controller of tray 30	Auto	---	changes to 76 °C	Acetic Acid feed valve will be open
Wait for the Tray 30's temperature is achieves to 76°C. Then, The controllers' tuning values change to nominal point set (based on Table 5). End					

* The initial temperature of tray 30 is equal to the boiling temperature of pure methanol (68.5 °C). The temperature controller on tray 30 also has a "direct" action type. As a result, in order to open the acetic acid flow valve (MP), the set point must be less than the value of the controlled variable. So, here, the setpoint is set at 60 °C.

Table 5: Temperature controller parameters during startup and normal operation (N.O.) based on CSI.

Tray 30 controller parameters	Startup	N.O.
Action	Direct	Direct
Gain	0.35	1.06
Integral time	60 min	21min
Derivative time	0 min	0 min
Tray 38 controller parameters	Startup	N.O.
Action	Direct	Direct
Gain	0.50	1.82
Integral time	60 min	21min
Derivative time	0 min	3.20 min

According to the findings, the controller tuning parameters play a significant role in steering the startup trajectory. So that it is not possible to direct the startup operation to the desired conditions by using the controller tuning parameters in normal operating conditions. Table 5 shows the temperature controller tuning parameters that were finally obtained.

To avoid deviation from the intended startup path, the controller should have slower dynamics (average control) during startup time. In other words, if the purpose of tuning

the control parameters is to influence the startup trajectory, the tuning logic should be compatible with an average control system. For this case study, the gain and integral time values for both controllers should be approximately one-third and three times, respectively, of the values found under normal operating conditions. If a tight control system is employed at startup operation, the eventual steady-state condition will be in agreement with the dotted line in Fig. 8, and the final product will be free of methyl acetate. It should be noted that the control parameter values obtained in normal operating conditions (N.O) were obtained utilizing the step response method. However, as previously indicated, the control parameters are programmed by trial and error in order to achieve the appropriate trajectory of the control variables during startup.

Fig. 10 shows the composition trajectories of trays 30 and 38 during the startup procedure from the initial conditions (pure methanol) to reaching the desired steady-state condition using the CSI control structure based on an average control system.

As previously stated, the tight control system cannot be used to direct the composition's trajectory and slide it on the reactive plate towards the desired zone (according to

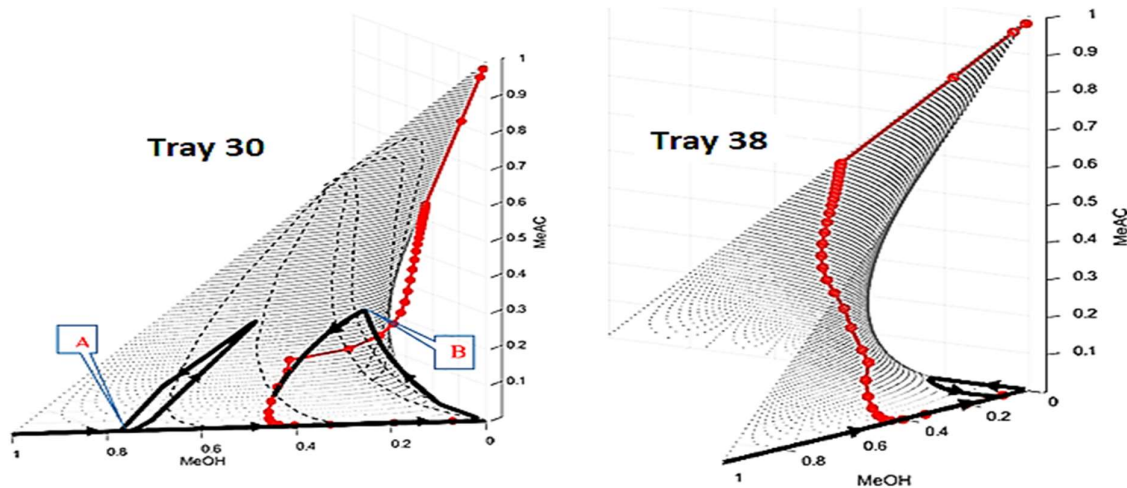

Fig. 10: Simulated composition trajectories of tray 30 and tray 38 (lines with arrows) during the startup operation.

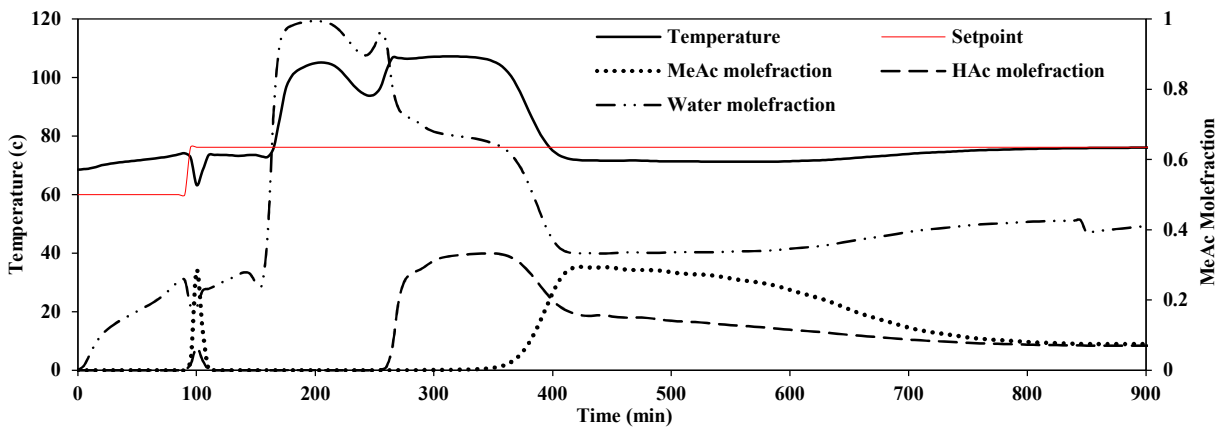

Fig. 11: Variations of temperature (Controller PV) and compositions of tray 30 based on CSI during startup time.

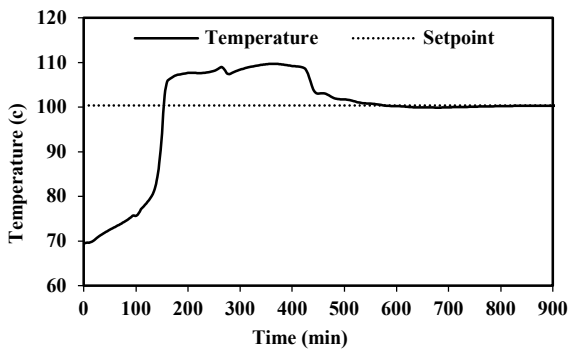

Fig. 12: Variations of temperature (Controller PV) of tray 38 based on CSI during startup time.

the reactive RCM). Because if this system is used, the temperatures of both trays will be reached at the set points before the compositions on the top of the column reach the

desired zone. In other words, using average control allows the composition of methyl acetate from point A to point B to remain in the zero range, as shown in Fig. 10. When an average control system with a low gain is used for the tray 30 temperature controller, the increasing rate of acetic acid feed is such that acetic acid does not enter tray 30 from time A to time B. It is important to note that with this strategy, only the amount of water in tray 30 will increase between these two points. Figs. 11 to 14 represent the changes in the control variables, the output of the controllers, the product purity, and the programming of the set points during the startup time.

CONCLUSION

The dynamic simulation results of a proposed startup procedure were investigated in this article. According to the

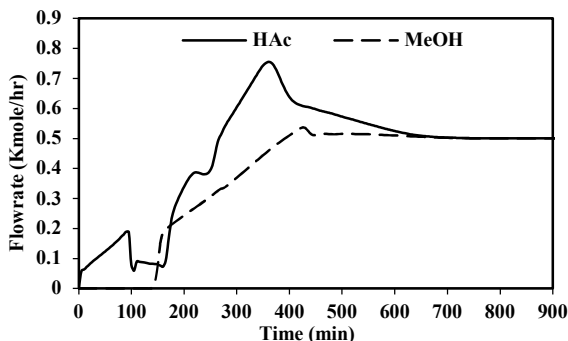

Fig. 13: Variations of feeds flowrate based on CSI during startup time.

findings, an appropriate decentralized control structure can navigate the composition's trajectory on the reaction equilibrium plane during the startup operation. In addition, it was found that the time to switch the sump level and reflux ratio controllers from manual to automatic (or cascade) during the startup operation plays a critical role in steering the startup operation towards the desired trajectory. In fact, the switch time of the controllers mentioned is proportional to the time acetic acid enters the reactive tray 30, the temperature of which is controlled by the amount of acetic acid entering the column. In other words, when unreacted acetic acid enters tray 30, a large amount of methyl acetate is produced, which, combined with a significant decrease in temperature, causes the desired path to deviate towards the undesired condition. At this point, a portion of the methyl acetate produced should be quickly removed from the column by switching the reflux ratio controller mode from manual to cascade mode and preventing it from falling excessively into tray 30. However, due to the temperature lag in the trays, if the system is waiting for the action of tray 30's temperature controller to compensate for its temperature decrease, it cannot prevent acetic acid from entering tray 30 because it takes a long time. To reduce acetic acid entry quickly, the set point of the tray 30's temperature controller should be increased at the same time as switching the reflux ratio controller mode.

Among the other results is the role of the average control system in variables trajectory control during startup. The results show that using tight temperature control of the sensitive trays in the CSI control structure during the startup operation will almost certainly result in undesired production.

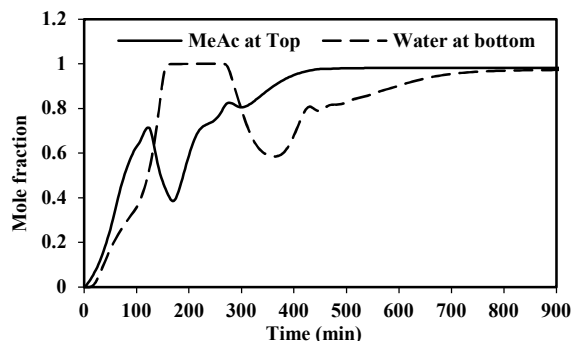

Fig. 14: Variations of products purities based on CSI during startup time.

As can be seen in Figs 11 to 14, using the proposed method, the start-up time will be around 10 hours. It should be noted that the time mentioned in other works about the start-up of the mentioned process is in the range of 8 to 16 hours, and thus, from this point of view, the proposed method can compete with other methods [4,5,21].

Acknowledgements

The producer of ABTIN RESIN INDUSTRIAL CO., as well as engineer Masoud Pakizeh Seresht, are thanked for providing research funds as well as technical experience and experimental information.

Received: Mar. 25, 2023 ; Accepted: Jun. 26, 2023

References

- [1] Baldon J.L., Strifezza J.J., Basualdo M.S., Ruiz C.A., [Control Policy for the Startup, Semi-Continuous and Continuous Operation of a Reactive Distillation Column](#), *IFAC Procee. Volum.*, **30(9)**: 121-126 (1997).
- [2] Scenna N.J., Ruiz C.A., Benz S.J., [Dynamic Simulation of Startup Procedures of Reactive Distillation Columns](#), *Computers & Chemical Engineering*, **22**: S719-S722 (1998).
- [3] Scenna N.J., Benz S.J., [Startup Operation of Reactive Columns with Multiple Steady States: The Ethylene Glycol Case](#), *Industrial & Engineering Chemistry Research*, **42(4)**: 873-882 (2003).
- [4] Reepmeyer F., Repke J.U., Wozny G., [time Optimal Startup Strategies for Reactive Distillation Columns](#), *Chemical Engineering Science*, **59(20)**: 4339-4347 (2004).

- [5] Reepmeyer F., Repke J.U., Wozny G., [Analysing the Startup of Reactive Distillation Columns](#), *IFAC Proceedings Volumes*, **37(1)**: 731-736 (2004).
- [6] Haßkerl D., Lindscheid C., Subramanian S., Markert S., Górak A., Engell S., [Application of Economics Optimizing Control to a Two-Step Transesterification Reaction in a Pilot-Scale Reactive Distillation Column](#), *IFAC-PapersOnLine*, **51(18)**: 67-72 (2018).
- [7] Al-Arfaj M., Luyben W.L., [Comparison of Alternative Control Structures for an Ideal Two-Product Reactive Distillation Column](#), *Ind. Eng. Chem. Res.*, **39(9)**: 3298–3307 (2000).
- [8] Al-Arfaj M., Luyben W.L., [Comparative Control Study of Ideal and Methyl Acetate Reactive Distillation](#), *Chemical Engineering Science*, **57(24)**: 5039–5050 (2002).
- [9] Kumar M.V.P., Kaistha N., [Temperature based Inferential Control of a Methyl Acetate Reactive Distillation Column](#), *Chemical Engineering Research and Design*, **85(9)**: 1268-1280 (2007).
- [10] Kumar M.V.P., Kaistha N., [Internal Heat Integration and Controllability of Double Feed Reactive Distillation Columns, 1. Effect of Feed Tray Location](#), *Ind. Eng. Chem. Res.*, **47(19)**: 7294–7303 (2008).
- [11] Kumar M.V.P., Kaistha N., [Role of Multiplicity in Reactive Distillation Control System Design](#), *Journal of Process Control*, **18(7-8)**: 692–706 (2008).
- [12] Kumar M.V.P., Kaistha N., [Evaluation of Ratio Control Schemes in a Two-Temperature Control Structure for a Methyl Acetate Reactive Distillation Column](#), *Chemical engineering research and design*, **87(2)**: 216–225 (2009).
- [13] Tang Y. T., Chen Y. W., Huang H. P., Yu C. C., Hung S. B., Lee M. J., [design of Reactive Distillations for Acetic Acid Esterification](#), *AIChE Journal*, **51(6)**: 1683-1699 (2005).
- [14] Pöpken T., Götze L., Gmehling J., [Reaction Kinetics and Chemical Equilibrium of Homogeneously and Heterogeneously Catalyzed Acetic Acid Esterification with Methanol and Methyl Acetate Hydrolysis](#), *Ind. Eng. Chem. Res.*, **39(7)**: 2601–2611 (2000).
- [15] Sawistowski H., Pilavakis P.A., [Vapor-Liquid Equilibrium with Association in both Phases: Multicomponent Systems Containing Acetic Acid](#), *J. Chem. Eng. Data.*, **27(1)**: 64-71 (1982).
- [16] Álvarez V.H., Mattedi S., Iglesias M., Gonzalez-Olmos R., Resa J., [Phase Equilibria of Binary Mixtures Containing Methyl Acetate, Water, Methanol or Ethanol at 101.3 kPa](#), *Physics and Chemistry of Liquids*, **49**: 52-71 (2011).
- [17] Cai J., Cui X., Zhang Y., Li R., Feng T. [Isobaric, Vapor–Liquid Equilibrium for Methanol + Methyl Acetate + 1-Octyl-3-Methylimidazolium Hexafluorophosphate at 101.3 kPa](#), *J. Chem. Eng. Data.*, **56(6)**: 2884–2888 (2011).
- [18] Nagata I., [Vapor-Liquid Equilibrium data for the Binary Systems Methanol-Benzene and Methyl Acetate-Methanol](#), *J. Chem. Eng. Data*, **14(4)**: 418–420 (1969).
- [19] Huss R. S., Chen F., [Reactive Distillation for Methyl Acetate Production](#), *Computers & Chemical Engineering*, **27(12)**: 1855-1866 (2003).
- [20] Ganesh B., Yamuna R., Satyavathi B., [Development of Kinetic Models for Acid-Catalyzed Methyl Acetate Formation Reaction: Effect of Catalyst Concentration and Water Inhibition](#), *Int. J. Chem. Kinet.*, **43(5)**: 263–277 (2011).
- [21] Forner F., Brehelin M., Rouzineau D., Meyer M., Repke J., [Startup of a Reactive Distillation Process with a Decanter](#), *Chemical Engineering and Processing: Process Intensification*, **47(11)**: 1976-1985 (2008).