

Longitudinal Vibrations Analysis of Vehicular Clutch

¹R. Esfahani, ²A. Farshidianfar, ³A. Shahrjerdi, ⁴F. Mustapha

¹Advanced technology institute, University Putra Malaysia, Kuala Lumpur, Malaysia

²Engineering Department, University of Ferdowsi, Mashhad, Iran

³Department of Mechanical and Manufacturing Engineering, Universiti Putra Malaysia, 43400 UPM, Serdang, Selangor, Malaysia

⁴Department of Aerospace Engineering, Universiti Putra Malaysia, 43400 UPM, Serdang, Selangor, Malaysia

Abstract: This paper investigates the dynamic nature of clutch pedal in-cycle vibration as a powertrain NVH concern. The concern, referred to as “whoop” in industry, occurs during the clutch engagement and disengagement processes. The MATLAB and ADAMS as powerful programs for simulating dynamic systems to model clutch actuation system as a series of multi-bodies between the flywheel and the clutch pedal are used. Finally, the results are compared to experimental evidence and other models which were provided before.

Key words: Clutch, Vibration, Multi-body dynamics, Whoop

INTRODUCTION

The term “whoop”, or in-cycle vibration, is applied to a clutch pedal operating noise and vibration problem, which can be both heard as noise in driver’s footwell area and felt as vibration through the clutch pedal. This phenomenon occurs during the depression and release of the clutch pedal in a motor vehicle. The critical range for the release system of the clutch is at frequency of 200-300 Hz, when the clutch pedal is being operated. Therefore, this is a dynamic or in-cycle concern. Observations have indicated that vehicles with diesel engines and mechanically actuated clutch are more prone to this phenomenon (Kelly, P. and Rahnejat, H. 1997; Rahnejat, H. and Whalley R., 1997). It is shown that whoop is excited by the elastodynamic response of the crankshaft, caused by the combustion of the engine cylinders (Kelly, P. and Rahnejat, H. 1997; Rahnejat, H. and R. Whalley (Eds.), 1997; Rahnejat, H. *et al* 1997; Kelly, P., 1997). The frequency and the amplitude of the vibration depend on the design parameters of the clutch and of the clutch actuation system. Whoop has been observed experimentally to be an axial vibration problem (Kelly, P., 1997; Kelly, P., *et al*, 1998).

The traditional approach in dealing with this problem has been a palliative rather than a preventive one. Although various palliative measures have been advocated, a typical solution has been the use of a “Diehl fix”. This is a mass and a rubber block damper attached to the clutch release lever, in effect shifting the natural frequency of its oscillations from the normal 250-270 Hz range to around 450-520Hz. At these higher frequencies the amplitudes of oscillations are considerably reduced and the problem is shifted to higher engine speeds (Kelly, P., 1997). Aside from its palliative nature there are cost and weight penalties associated with the use of the “Diehl fix”, figure 1. The mass of the fix is usually up to 1 kg and its addition to the lever increase the cost of assembly typically by £3.5. With an annual production rate of several million vehicles in Europe, the cost to the industry is substantial (Kelly, P., Rahnejat, H. 1999). Therefore, an in-depth investigation of whoop is essential and a prerequisite for preventive measures.

A review of the published literature indicates that most of the research effort has been directed towards the torsional clutch vibrations, whilst the problems connected with the axial clutch vibrations have been studied to a lesser extent. Former research by (Hasebe, T. and Aisin Seiki, U.A. 1993) deals with the specific dynamic clutch pedal noise and vibration attempted to show that the pedal vibration and interior noise are mostly affected by the dynamic characteristic of the clutch cover assembly. The research included a vehicle vibration observation and non-running engine rig experiment connecting the excitation. They stated that the clutch pedal noise and vibration path emanated from the flywheel vibration and was transmitted through the clutch and

Corresponding Author: R. Esfahani, Advanced technology institute, University Putra Malaysia, Kuala Lumpur, Malaysia

actuation system. Measurements were made at various engine speeds and different clutch positions, on a stationary petrol car with the transmission in neutral.

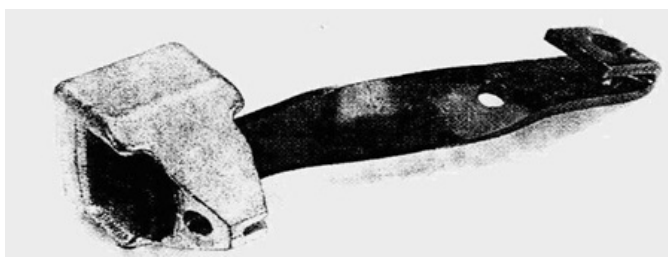

Fig. 1: Typical whoop fix lever (Kelly, P., *et al*, 1998).

They found that the pedal vibration and noise peaks occurred at the just disengaged position of the pedal vibration and with the engine running at 4400rpm. The pedal vibration consisted of first, third and sixth harmonics of engine rotation, and interior passenger noise consisted of third harmonic. Based on these results the research focused on the 200 to 300Hz range where the third engine harmonic had its peak magnitude.

More investigations were performed by (Kelly, P., 1997). The research for Ford attempted to discover the influence of the individual component parts on the transmission of the subsequent vibration and noise. The investigation included a vehicle vibration observation and multi-body model of clutch provided by ADAMS. They stated that the cause of the pedal vibration and noise was identified as the 1/2 order engine excitation from the 4th cylinder resulting in bending of the crankshaft, thus resulting in the nodding vibration of the flywheel and this forced excitation is always present in the system, figure 2. It only translates to a pedal vibration complaint when the downstream conditions permit. They showed how effective the cable, mass fixes and clutch cover stiffness can be.

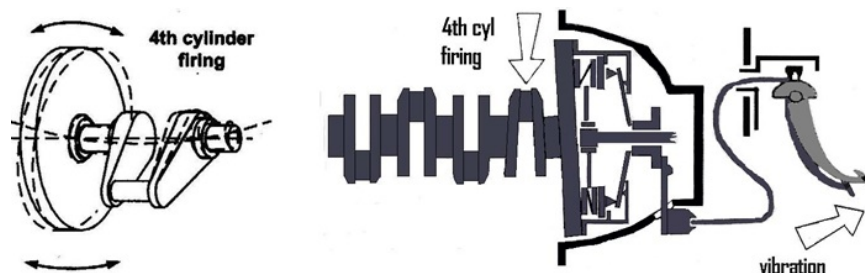

Fig. 2: Crankshaft bending impulse to clutch system resulting in pedal vibration (Kelly, P., *et al*, 1998).

In this paper the whoop problem of clutch is modeled in MATLAB by simplified lump model which is proposed. Then, ADAMS is used to simulate a complete clutch from flywheel to pedal. Lastly, the results are compared to experimental investigations and other models.

Cable-operated Vehicle Clutch System:

The primary function of the clutch is to transmit and disconnect the torque between the engine and the drivetrain system and to permit gear selection. Figure 3 is a schematic representation of a cable operated clutch system. It extends from the pedal, through an actuation mechanism, through to the transmission bell-housing and onto the release bearing. During the engagement process the release bearing slides along the transmission input shaft and is pressed against diaphragm fingers of the clutch. The flexion of the fingers (acting as levers) cause the pressure plate lift in the axial direction and effect the clamping of pressure plate-dry friction-flywheel assembly.

A clutch is defined by three characteristic curves; the clamp load, the release load and pressure plate lift. For a specific clutch, the characteristics are supplied by the clutch manufacturer on a single graph, as shown in figure 4. (Shaver, R.).

The Clutch Model:

The advantage of developing a detailed model of the clutch system is evident. When such a model is

validated against experimental evidence it can be subsequently employed to carry out many DoE studies through virtual prototyping simulations. This approach is becoming more commonplace in industry as the cost

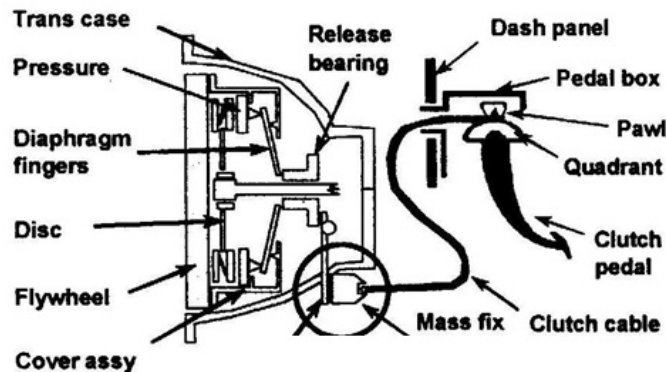

Fig. 3: Cable operated clutch system (Kelly, P., Rahnejat, H.).

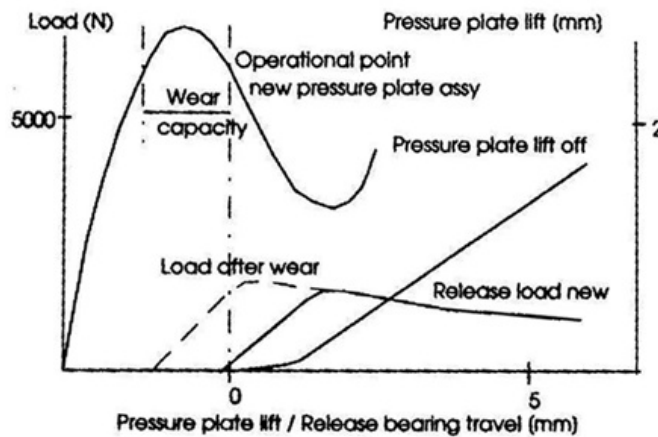

Fig. 4: Clutch characteristics (Shaver, R.).

of development of experimental rigs, condition monitoring and analyses can be prohibitive when a large number of factors are to be investigated, many of which interact with one another. The object of creating the multi-body dynamic model was to simulate the clutch system to ascertain the natural frequency of the system for different parameter changes.

In this paper the whoop frequency is investigated with two commercial programs MATLAB and ADAMS.

1- Matlab Model:

MATLAB is powerful program for solving and simulating numerical problem. This program is employed for generic model for cable-operated clutch system for diesel passenger cars for whoop phenomena. In order to modeling clutch in MATLAB, the equivalent lumped model is considered. However, the model have a function of clutch, it should be able to extract the equations of motion easily. This proposed model is shown in figure 3. This model includes five lumped mass which are pedal, cover, release lever-system, pressure plate, flywheel. These masses are connected with elastic elements which are cable stiffness that is assumed without mass, diaphragm fingers, diaphragm spring, cushion spring and finally, cover stiffness which connects cover to flywheel. Among these springs, the cushion spring, diaphragm spring and diaphragm fingers are non-linear, shown in figure 4, cable stiffness and cover stiffness are linear. The coupling between the pressure plate and cover is made by a lever without mass with appropriate ratio that is shown in figure 3.

The equivalent masses and springs are computed by kinetic and potential energy expressions. The procedures employed to obtain these values is provided in all standard texts such as Thomson, W.T. (1976) or Rao, S.S. (1995). The equivalent mass of pedal is calculated as an example.

According to figure 4 and kinetic expression the equivalent mass of pedal is obtained as

$$\frac{1}{2} I_o \dot{\theta}^2 = \frac{1}{2} m_{pe} \dot{X}_{pe}^2 \tag{1}$$

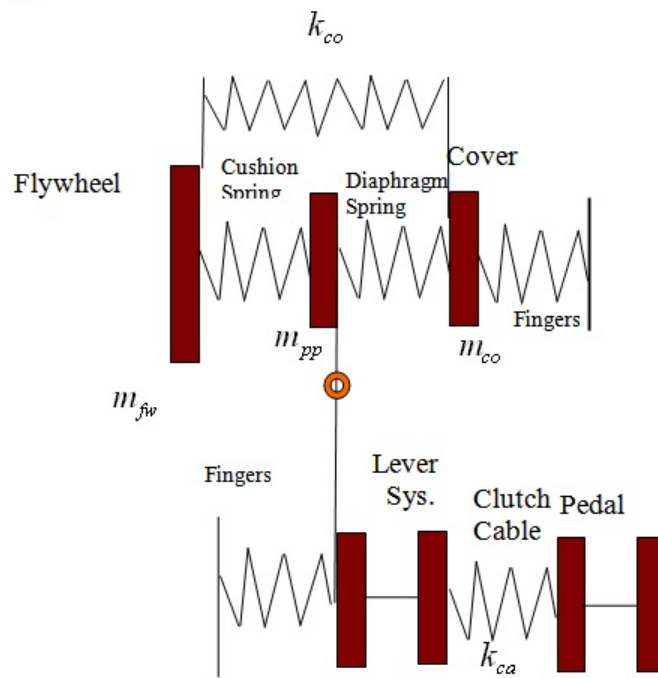

Fig. 3: The simplified schematic model.

$$X_{pe} \approx a_{pe} \theta \tag{2}$$

From equations (1) and (2):

$$m_{pe} = \frac{I_o}{a_{pe}^2} \tag{3}$$

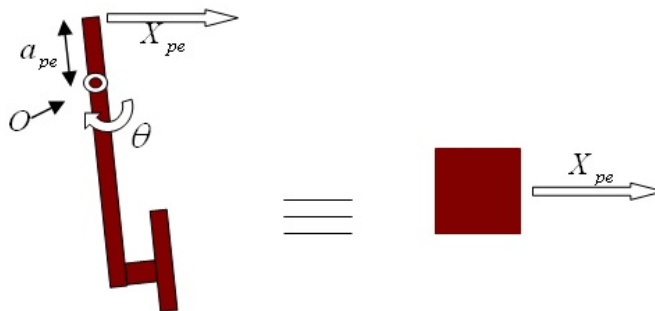

Fig. 4: Calculating equivalent mass of pedal

Equations of motion are as follows:

Pedal:

$$m_{pe} \ddot{x}_{pe} = -k_{ca} (x_{pe} - x_{ls}) + F(t) \tag{4}$$

Where

$F(t)$ is the pedal effort.

Flywheel:

$$m_{fw} \ddot{x}_{fw} = -k_{co} (x_{fw} - x_{co}) - F_{cs} - k_{cr} x_{fw} + F(t) \tag{5}$$

Where

F_{cs} is force of cushion spring, $F(t)$ is the impact force excitation in combustion frequency applied to the flywheel to represent the engine knocking effect and k_{co} is the stiffness of cover.

Cover:

$$m_{co} \ddot{x}_{co} = -F_{ds} - F_f \tag{6}$$

Where

F_{ds} is the force of diaphragm spring and F_f is the force of fingers.

Lever system and pressure plate:

$$I_o \ddot{\theta} = -F_{ds} \times a - F_f \times b - k_{ca} (x_{ls} - x_{pe}) \times b \tag{7}$$

Where

a and b are the distances between the joint and pressure plate and lever system respectively.

The model of the clutch is created in SIMULINK by the equations (1) to (7). It is shown in figure 5. This model has four subsystems which are pedal, cover, flywheel and pressure plat that includes lever system and pressure plate together. The inputs to the model are a Dirac force function of the duration equivalent to half engine order combustion process with nominal amplitude that is applied to the flywheel as an impact force and the pedal effort which is applied to the pedal directly. The model outputs are Fast Fourier Transformation of vibration spectrums of the lever acceleration since the experimental results are shown vibration spectrum of lever (Kelly, P., 1997; Hasebe, T. and Aisin Seiki, U.A. 1993).

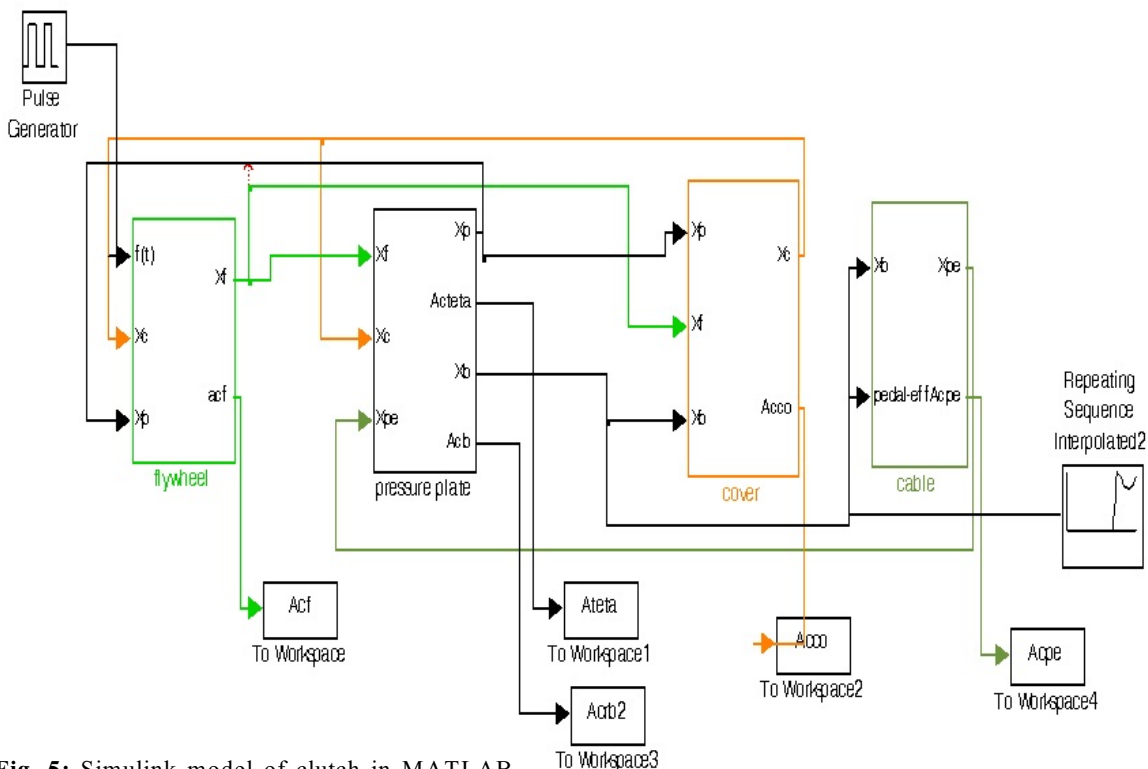

Fig. 5: Simulink model of clutch in MATLAB

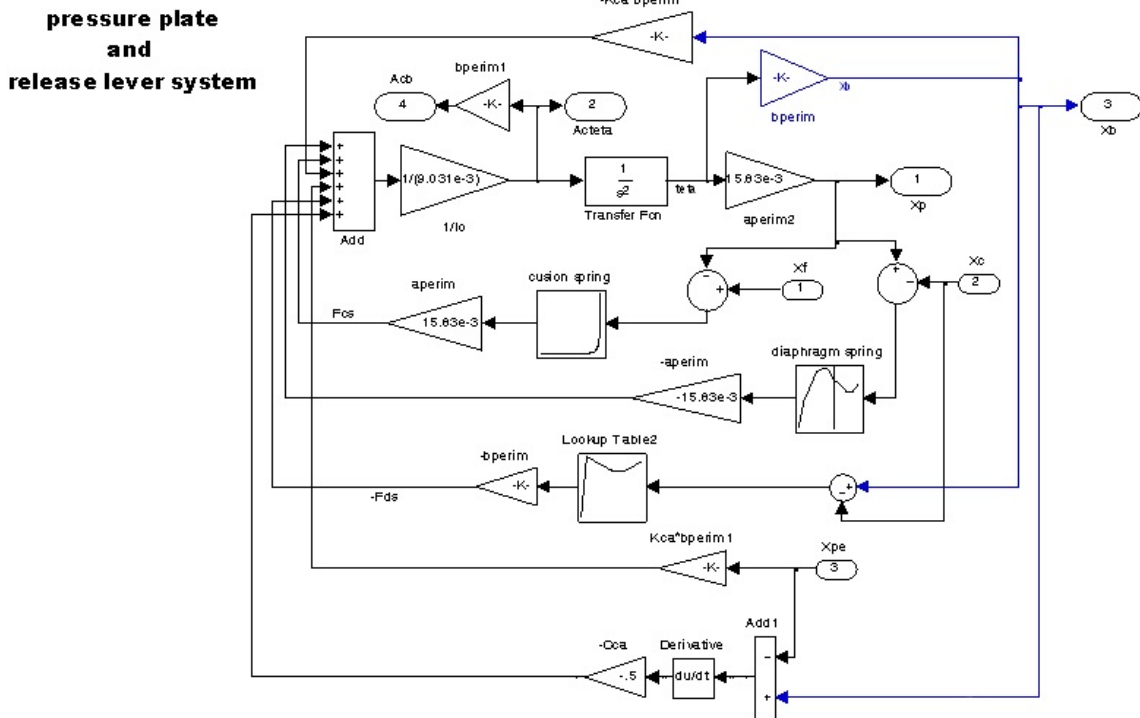

Fig. 6: Pressure plate subsystem.

Figure 7 is shown vibration spectrum of lever system. There are a number of marked peaks and their side bands in the spectrum. These are the 4th engine order being significant as it resides in the vicinity of the cable natural frequency at 100Hz (Rahnejat, H., 1998), the whoop frequency at 233Hz and its first harmonic at approximately 466Hz. Very good agreement is observed with experimental spectrum. (see figure 8).

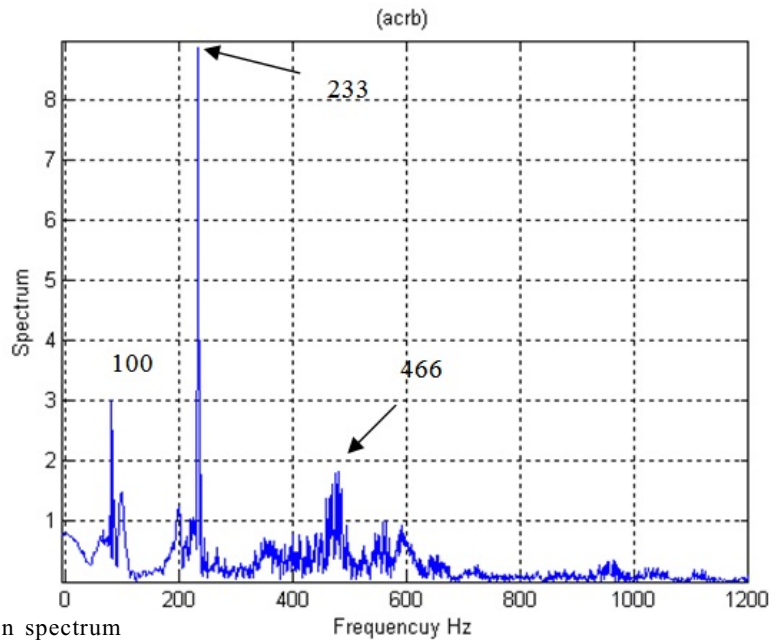

Fig. 7: Lever vibration spectrum

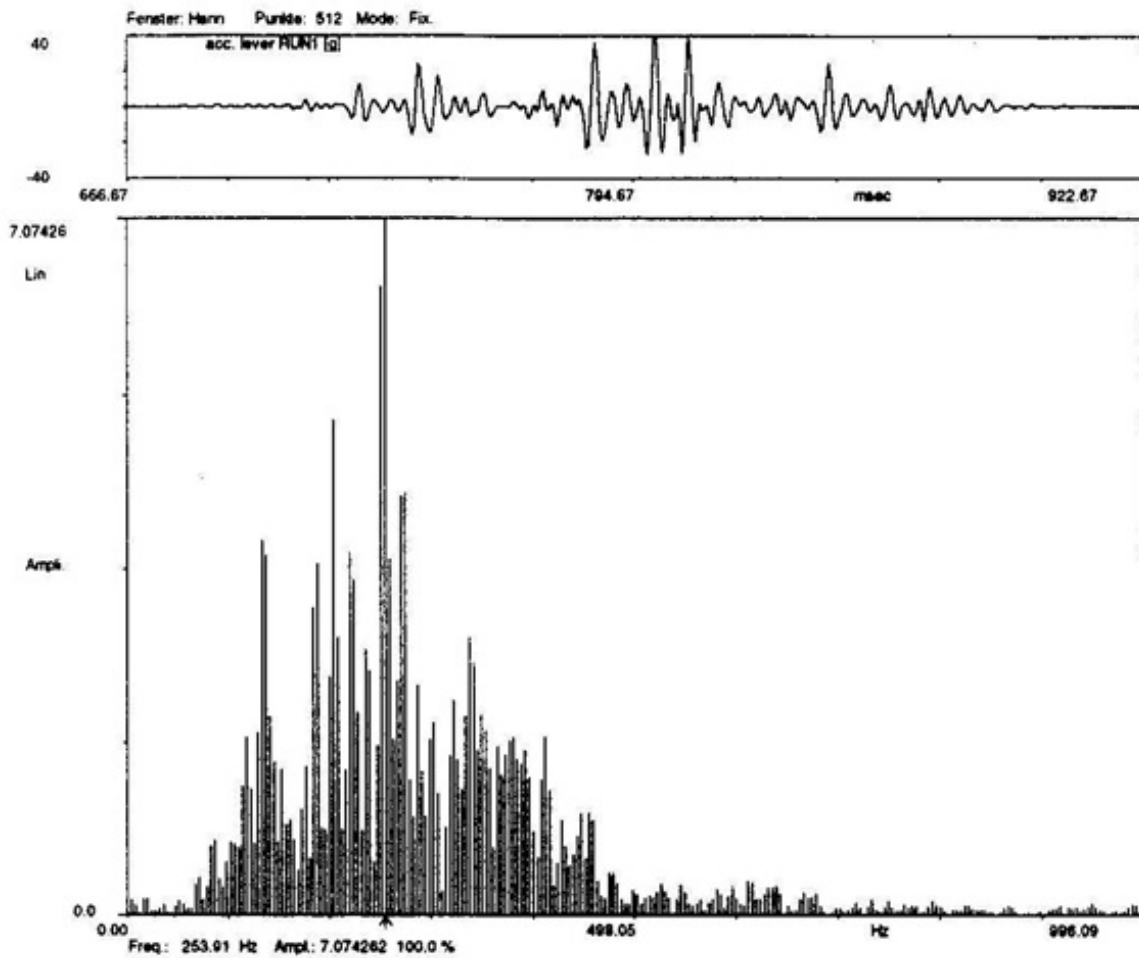

Fig. 8: Experimental measure whoop spectrum without a mass on the lever (Rahnejat, H., 1998).

2- ADAMS Model:

ADAMS is an acronym for Automotive Dynamic Analysis of Mechanical System. This is employed for generic model for cable-operated clutch system for diesel passenger cars. The model includes 12 rigid parts, as shown in table 1. Each part accounts for 6 unconstrained degrees of freedom. The constraints imposed between the various clutch system components are modeled using appropriate scalar constraint functions that represent joints.

Table 1 also lists the constraint functions employed in the multi-body model. Each of the 69 constraints is represented by an algebraic function. Each degree of freedom is represented by differential equation of motion (72 in this multi-body model). Therefore, there are 4 unconstrained independent degrees of freedom in the model. These are the translational/floating of flywheel/cover assembly, the articulating of release lever and the movement of the clutch pedal. The simplified schematic representation of the model is shown in figure 8.

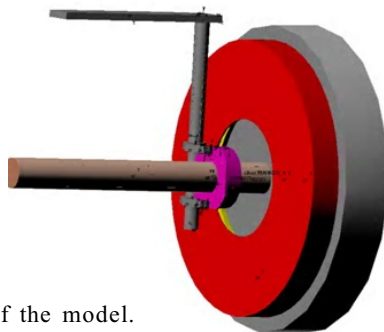

Fig. 8: A simplified schematic of the model.

The input is given by a Dirac force function of short duration with amplitude of 100 N applied directly to the flywheel. This simulates the impact during flywheel bending. The application of a Dirac function excites all the natural modes of the powertrain with the fundamental forcing frequency (i.e. 16.7 Hz) and all its higher harmonics that include all the whole and half multiples of engine order. This is a true test in ascertaining the propensity of the clutch system to whoop in resonance with any given engine order.

Table 1: the parts in the ADAMS multi-body model

Rigid parts	Part Name	Typical Mass(kg)	Constraint		
			Function	Type	No.of
	Ground	-	-		
1	Housing	20	Ground	Fix	6
2	Flywheel	4.5	Ground	Translational	5
3	Friction disc	0.5	Flywheel	Fix	6
4	Pressure plate	2.0	Housing	Translational	5
			Bearing	Coupler	1
5	Cover	1.5	Flywheel	Fix	6
6	Bearing	0.2	Housing	Translational	5
			Release shaft	Curve-curve	2
7	Input shaft	2.0	housing	Fix	6
8	Release shaft	0.5	housing	Cylindrical	4
9	Lever	0.5	Release shaft	Fix	6
10	Pedal box	2.5	ground	Fix	6
11	Quadrant	0.1	pedal	Fix	6
12	Pedal	0.5	Pedal box	revolute	5
	Σ constraints				69

Figure 7 and 8 show the results of simulation of multi-body clutch system model, undertaken for a period of 0.4 seconds. The applied axial engine transmitted force acts on flywheel and the clutch pedal force is also employed. The pedal force is in fact applied after 0.2 seconds for a period of 0.1 seconds. This can be ascertained from figure 7. This figure shows the axial vibrations of the clutch monitored at the lever in terms of lever translational acceleration. It indicates that from the onset of application of pedal load vibrations occur, which decay rapidly when the pedal effort is removed. Fast Fourier Transformation of time history of lever vibrations of figure 7; provide the spectral contents shown in figure 8. There is a significant contribution at 240 Hz (the fundamental axial vibrations frequency of the system). Remarkable agreement is found with the experimental vehicle test spectrum reported in (Kelly, P. and H. Rahnejat, 1997). The experimentally monitored fundamental is at 257 Hz

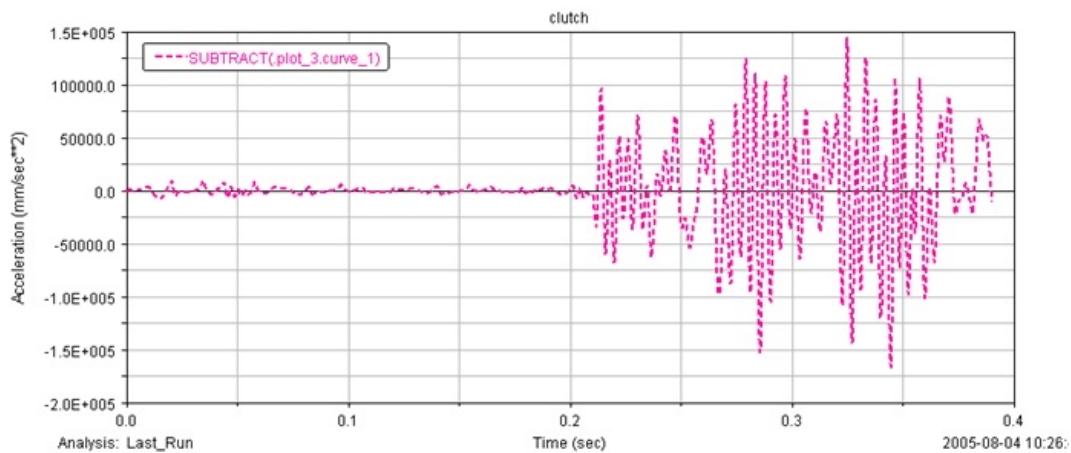

Fig. 9: Model predictions-time history

Longitudinal vibration of clutch was modeled by Kelly, P., (1997) in ITI and ADAMS also. The results of them and the models which are calculated in this article are shown in table 2.

Table 2: Numerical results against experimental prediction

Model/vehicle	Natural Frequency (Hz)
Model-ADAMS (Rahnejat, H., <i>et al</i> , 1997)	220
Model-ITI (Rahnejat, H., <i>et al</i> , 1997)	226
Model-ADAMS	246
Model-MATLAB	233
Vehicle(Rahnejat, H., <i>et al</i> , 1997)	257

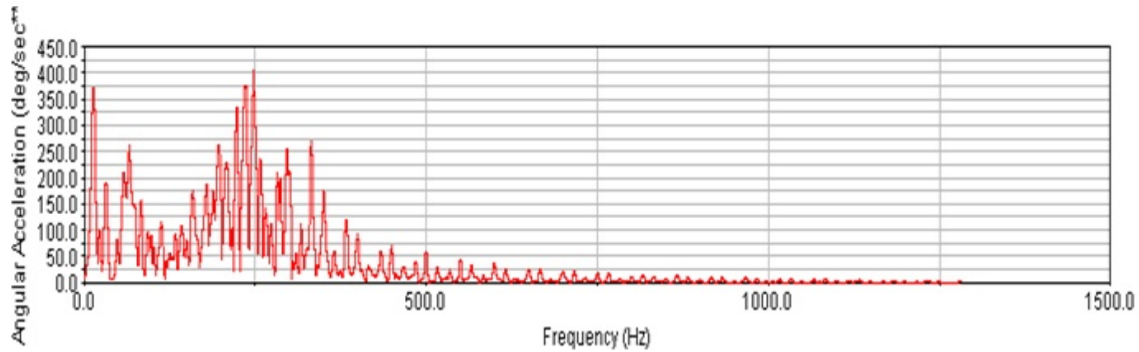

Fig. 10: Model predictions-spectrum

Conclusion:

The clutch whoop problem has been modeled by powerful programs MATLAB and ADAMS. Then, these models are validated against experimental evidence. The proposed MATLAB model has benefits in compare to other models. The equations are made by user; hence, user could alter any things in model clearly. The MATLAB is widely available and is cheaper than ADAMS. Finally, the MATLAB has powerful available toolboxes in optimization and control systems; therefore, the models can be subsequently employed to carry out many DoE studies through virtual prototyping simulations and they can give more valuable results.

REFERENCES

Hasebe, T. and U.A. Aisin Seiki, 1993. “Experimental Study of Reduction Methods for Clutch Pedal Vibration and Drive Train Rattling Noise from Clutch System” SAE Pap. No.932007.

Kelly, P. and H. Rahnejat, 1997. Clutch pedal dynamic noise and vibration investigation. MEP (IMechE).

Kelly, P., 1997. Clutch Pedal Noise and Vibration Analysis, MSc by Research Thesis, University of Bradford.

Kelly, P., H. Rahnejat, J.W. Biermann and B. Hagerodt, 1998. “Combining design of experiments and modeling techniques to resolve complex clutch pedal noise and vibration issues”, Proc. European Vehicle Noise and Vibration Conf., IMechE, London.

Kelly, P., H. Rahnejat, J.W. Biermann, 1999. “Multi-body dynamics investigation of clutch pedal in-cycle vibration (whoop)”, IMechE.

Kelly, P., H. Rahnejat, J.W. Biermann, “A Parametric Study of Clutch Pedal Whoop: Numerical Prediction and Experimental Verification”, 99SIO20.

Rahnejat, H. and R. Whalley (Eds.), 1997. Multi-body Dynamics: Monitoring and Simulation Techniques, MEP (IMechE).

Rahnejat, H., D. Centea and P. Kelly, 1997. Non-linear multi-body dynamic analysis for the study of in-cycle vibrations (whoop) of cable operated clutch systems”, Proc. 30th ISATA, Florence, Italy.

Rao, S.S., 1995. Mechanical vibrations, Addison-Wesley Publishing Company.

Rahnejat, H., 1998. Multi-Body Dynamics Vehicles, Machines, and Mechanisms, Society of Automotive Engineers, Inc. Warrendale, Pennsylvania, USA.

Shaver, R. Chrysler Corporation, Manual Transmission Clutch Systems, AE-17, Published by: SAE, Inc.

Thomson, W.T., 1976. Vibration theory and applications, George Allen and Unwin Ltd.