

Improving Power Plant Efficiency using Water Droplet Injection in Air Condensers

Mohammad Javadi*, A. Golshani, Amir Mahdi Ghasemi, Morteza Anbarsooz, M. Moghiman

Abstract—Observations show that power plant efficiency decreases in hot summer days. Water droplet injection in air condensers is suggested in order to decrease the inlet air temperature. Nozzle arrangement, injected water flow rate and droplets diameter effects on evaporation rate and the resulting air temperature are investigated using numerical simulation. Decreasing the diameter of injected droplets and increasing the number of injecting nozzles, decreases the outlet air temperature. Also a more uniform air temperature can be obtained using more injecting nozzles. Numerical results are in good agreement with analytical results.

Keywords—Power, Air Condenser, Evaporation, Droplet Injection

I. INTRODUCTION

The three main types of condensers which are commonly used are air cooled, water cooled and water evaporation condenser. The air cooled condensers (fin and tube heat exchangers) are the most widespread category for low and average refrigeration capacities because the cooling medium (air) is a free and natural source [1-3]. Air-cooled condensers are widely used to provide cooling energy for commercial and industrial premises such as air-conditioned buildings in the subtropical region, but with considerable electricity consumption [4-5]. These condensers have long been considered inefficient because they operate under head pressure control (HPC) whereby the condensing [6].

Although dry cooling can be a suitable candidate for substituting wet cooling systems, but it strongly depends on air temperature, and is incapable of maintaining the designed output power in hot days of the year. Air condensers are economical when air humidity is less than 5 percent and the air temperature is not more than expected. Water droplet injection in air condensers can be performed from different points such as injecting from bottom of the fan or injecting from side walls of the condenser. Improper injecting or using non deionized water droplets will cause corrosion. Injecting water droplets decreases air temperature which leads to efficiency improvement. It must be emphasized that although injecting water droplets increases the air humidity, the overall result of injecting droplets will increase the efficiency as has

been investigated in many countries such as China, South Africa, USA [7] because the effect of temperature is much heavier than humidity effects.

In this paper, water droplet injection in a typical air condenser is simulated with Fluent CFD code, and the effect of different parameters on its output temperature is investigated.

II. GOVERNING EQUATION

The average gas phase equations are as follows:

-Continuity:

$$\frac{\partial u}{\partial x} + \frac{\partial v}{\partial y} = 0 \quad (1)$$

-Momentum:

$$\left[\frac{\partial}{\partial x}(\rho u u) + \frac{\partial}{\partial y}(\rho u v) \right] = -\frac{\partial p}{\partial x} + \mu \nabla^2 u - \rho \overline{u'u'} - \frac{\partial}{\partial y}(\rho \overline{u'v'}) - \frac{\partial}{\partial z}(\rho \overline{u'w'}) \quad (2)$$

$$\left[\frac{\partial}{\partial x}(\rho u v) + \frac{\partial}{\partial y}(\rho v v) \right] = -\frac{\partial p}{\partial y} + \mu \nabla^2 v - \rho \overline{v'v'} - \frac{\partial}{\partial x}(\rho \overline{u'v'}) - \frac{\partial}{\partial z}(\rho \overline{v'w'}) \quad (3)$$

$$\left[\frac{\partial}{\partial x}(\rho u w) + \frac{\partial}{\partial z}(\rho v w) \right] = -\frac{\partial p}{\partial z} + \mu \nabla^2 w - \frac{\partial}{\partial x}(\rho \overline{u'w'}) - \frac{\partial}{\partial y}(\rho \overline{v'w'}) - \rho \overline{w'w'} \quad (4)$$

The simplest "complete models" of turbulence are two-equation models in which the solution of two separate transport equations allows the turbulent velocity and length scales to be independently determined. The standard $k - \varepsilon$ model in FLUENT falls within this class of turbulence model and has become the workhorse of practical engineering flow calculations in the time since it was proposed by Launder and Spalding [5]. Robustness, economy, and reasonable accuracy for a wide range of turbulent flows explain its popularity in industrial flow and heat transfer simulations. It is a semi-empirical model, and the derivation of the model equations relies on phenomenological considerations and empiricism. The standard $k - \varepsilon$ model [5] is a semi-empirical model based on model transport equations for the turbulence kinetic energy k and its dissipation rate (ε). The model transport equation for k is derived from the exact equation, while the model transport equation for ε was obtained using physical

*Phd Mechanical of engineering, Ferdowsi university of Mashhad, Iran (e-mail: mohammad.javadi@gmail.com).

Bsc Mechanical engineering, Toos Power Generation Management Co, Mashhad, Iran

Msc Mechanical of engineering, Ferdowsi university of Mashhad, Iran (e-mail: amir_m_ghasemi@yahoo.com).

Phd Mechanical of engineering, Ferdowsi university of Mashhad, Iran

Professor Mechanical engineering, Ferdowsi university of Mashhad, Iran

reasoning and bears little resemblance to its mathematically exact counterpart. In the derivation of the $k - \varepsilon$ model, the assumption is that the flow is fully turbulent, and the effects of molecular viscosity are negligible. The standard $k - \varepsilon$ model is therefore valid only for fully turbulent flows. The turbulence kinetic energy, k , and its rate of dissipation, ε , are obtained from the following transport equations:

$$\frac{\partial(\rho k)}{\partial t} + \text{div}(\rho k U) = \text{div} \left[\mu + \frac{\mu_t}{\sigma_k} \text{grad} k \right] + G_k + G_b - \rho \varepsilon - Y_M + S_K \quad (5)$$

$$\frac{\partial(\rho \varepsilon)}{\partial t} + \text{div}(\rho \varepsilon U) = \text{div} \left[\left(\mu + \frac{\mu_t}{\sigma_\varepsilon} \right) \text{grad} \varepsilon \right] + C_{1\varepsilon} \frac{\varepsilon}{K} (G_k + C_{3\varepsilon} G_b) - C_{2\varepsilon} \rho \frac{\varepsilon^2}{k} + S_\varepsilon \quad (6)$$

In these equations, G_k represents the generation of turbulence kinetic energy due to the mean velocity gradients. G_b is the generation of turbulence kinetic energy due to buoyancy. Y_M represents the contribution of the fluctuating dilatation in compressible turbulence to the overall dissipation rate. $C_{1\varepsilon}$, $C_{2\varepsilon}$, and $C_{3\varepsilon}$ are constants. σ_k and σ_ε are the turbulent Prandtl numbers for k and ε , respectively. S_k and S_ε are user-defined source terms. The turbulent (or eddy) viscosity, μ_t , is computed by combining k and ε as follows:

$$\mu_t = \rho C_\mu \frac{k^2}{\varepsilon} \quad (7)$$

Where C_μ is constant.

The model constants $C_{1\varepsilon}$, $C_{2\varepsilon}$, C_μ , σ_k and σ_ε have the following default values [196]:

$$\sigma_{1\varepsilon} = 1.44 \quad \sigma_{2\varepsilon} = 1.92 \quad \sigma_k = 1 \quad C_\mu = 0.09 \quad \sigma_\varepsilon = 1.3$$

Injection equations are discussed in fluent help 6.3.

III. FLOW SIMULATION

The geometry of the air condenser and boundary conditions are displayed in figure 1. A structured grid is generated using Gambit 2.3.16 software which is shown in figure 2. Injection is performed in two different ways. Once injection is done from 17 discrete points on the bottom surface of the condenser and in the other way the injection is done from the whole surface (which is an ideal configuration for injection and is practically difficult).

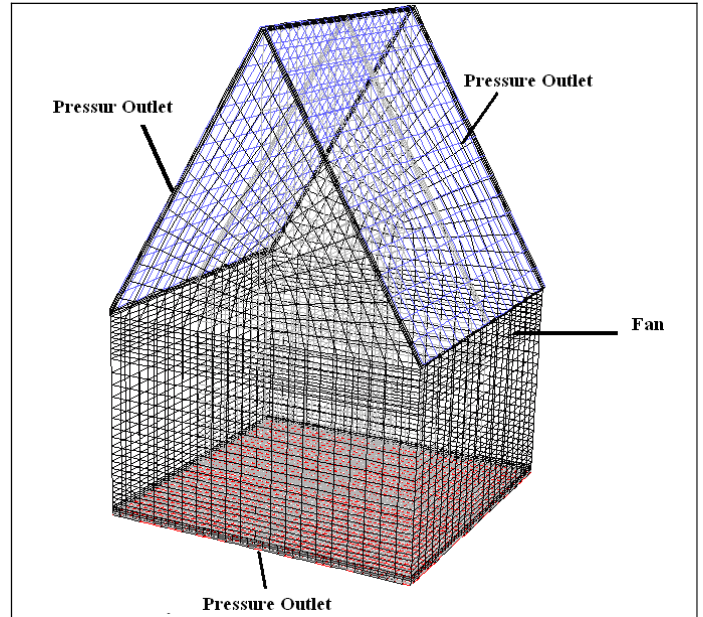

Figure 1- Geometry and the boundary conditions

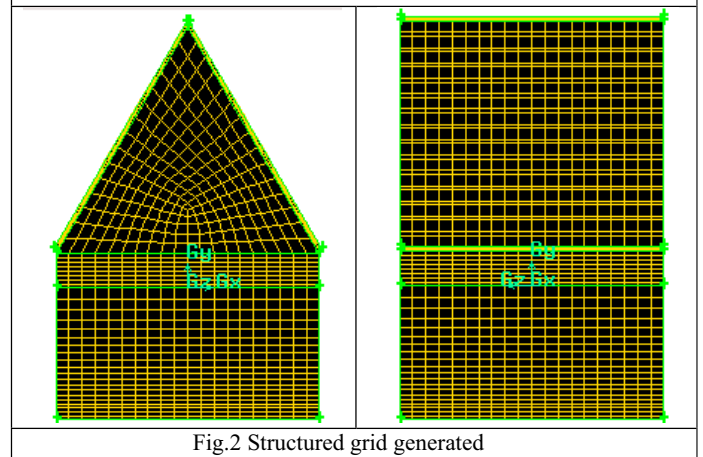

Fig.2 Structured grid generated

IV. RESULTS

In figures 3 and 4 temperature distribution is shown for two injection conditions with the water flow rate of 1.27 kg/s. When water is injected from the whole surface, the air and water are mixed better, so temperature is more decreased.

In order to investigate the effect of injected droplet size on temperature distribution, simulation was performed with two different ranges of droplet which are 1-5 micrometer and 1-10 micrometer. In figures 5 and 6 droplet trajectory for the two ranges of droplets diameter which are shown from three points are compared. As expected, small droplets evaporate rapidly. It must be noticed that if the diameter of droplets injection oversized, they will collide the upper surface of the condenser which leads to rustiness and corrosion. The best diameter range of injected droplets is the 1-10 micrometer range, since the droplets don't collide the fan blades of the condenser, furthermore they don't evaporate soon which causes more uniform temperature distribution.

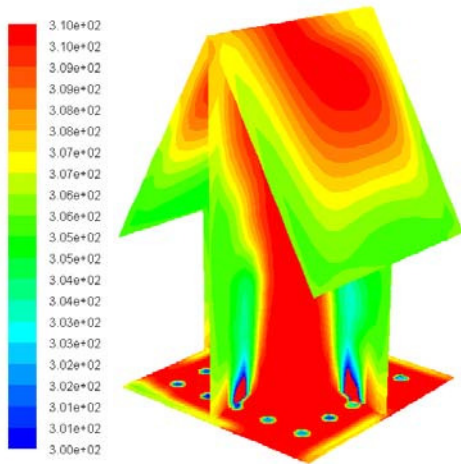

Figure.3 temperature distribution(k) Injecting from 17 points of surface with flow rate 1.27 kg/s

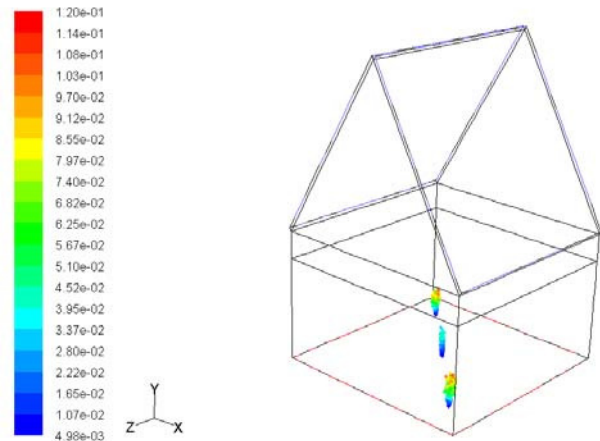

Fig.6 Injecting droplets in range of 1-5 micrometer

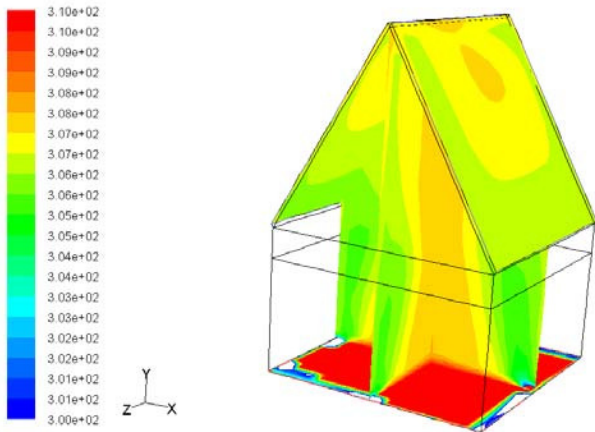

Figure.4 temperature distribution(k) Injecting from whole surface with flow rate 1.27 kg/s

In figures 7-10 the effect of injected water flow rate on temperature distribution is investigated. With increasing flow rate, temperature is decreased. With lower flow rates of water (fig. 7, 8 with flow rates of 0.85 kg/s and 1.27 kg/s) the temperature distribution is more uniform due to the better mixing of air and the water vapor compared to higher flow rates (fig.9, 10 with flow rates of 1.7kg/s and 1.8 kg/s). If water droplets are fully evaporated, and the evaporated water and the air are completely mixed, the calculated flow rate of the numerical simulation to obtain the condenser's design temperature is in good agreement with the calculations based on the psychrometric chart.

In figure 11 the output temperature for two injection types (injection from 17 points, injection from the whole surface) and the results based on psychrometric charts are compared. Result shows with injecting from the whole surface, simulated results are in good agreement with calculated results from psychrometric chart.

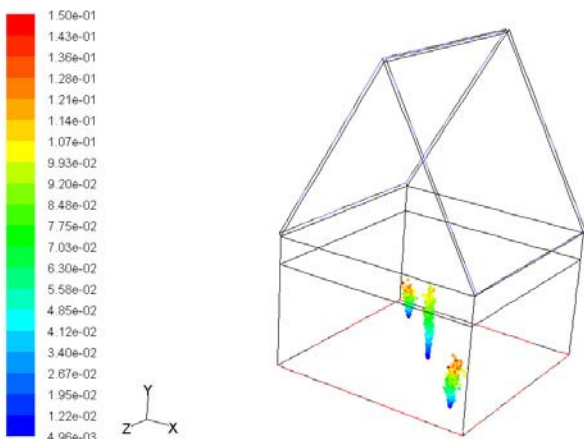

Fig.5 Injecting droplets in range of 1-10 micrometer

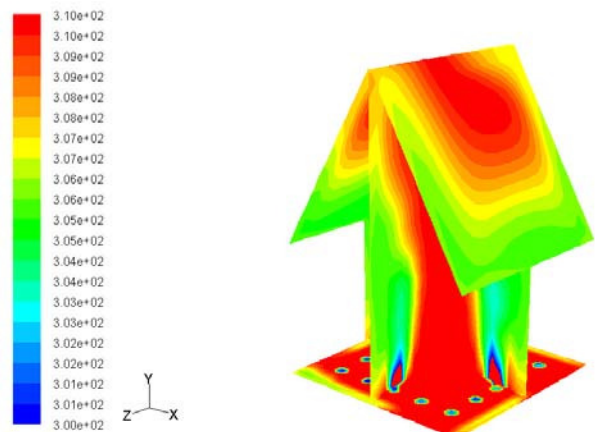

Fig.7 temperature distribution(k) with flow rate 1.27 kg/s

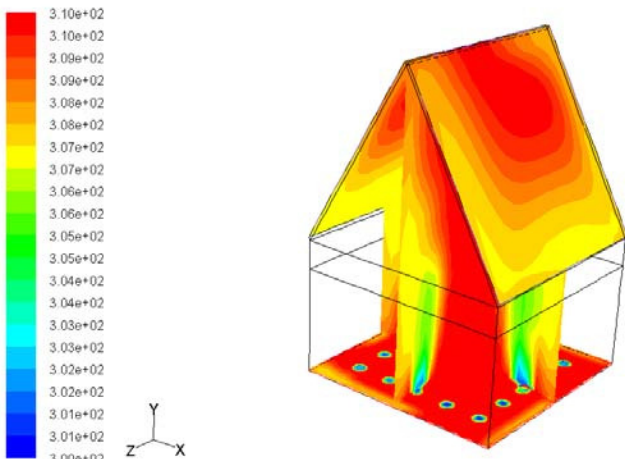

Fig.8 temperature distribution(k) with flow rate 0.85 kg/s

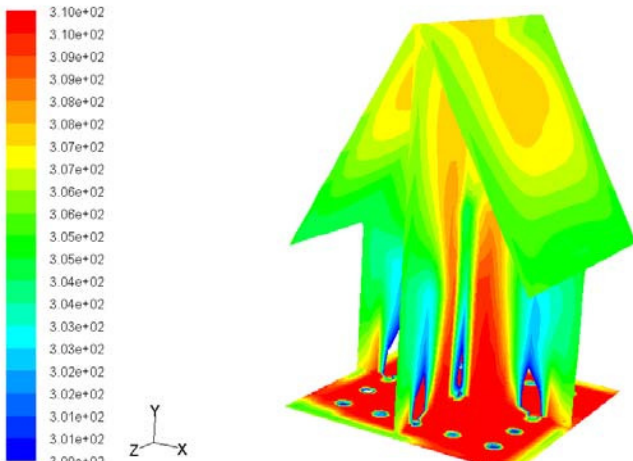

Fig.9 temperature distribution(k) with flow rate 1.7 kg/s

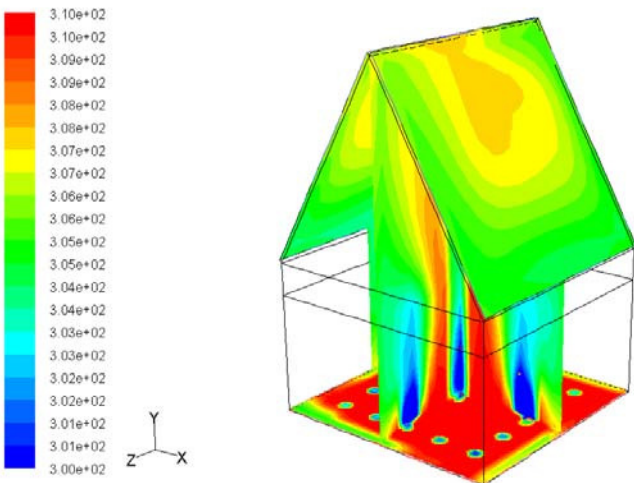

Fig.10 temperature distribution(k) with flow rate 1.8kg/s

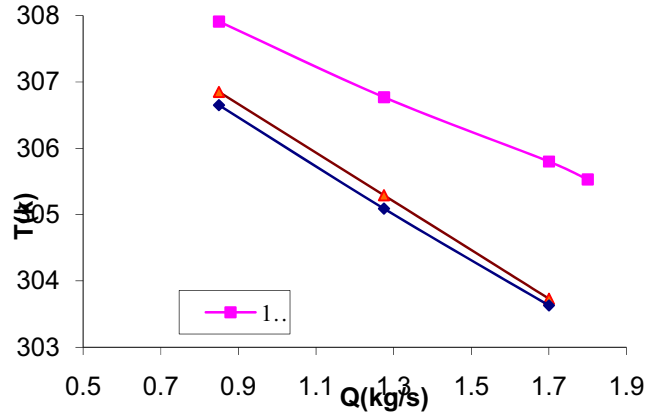

Fig.11 comparison simulated and calculated results of the effect of nozzle arrangement on output temperature

Figure 12 shows the effect of size of droplets with two different flow rates on output temperature. Results show that injecting droplets with the diameter in the range of 1-10 micrometers are a suitable range for condensers, since they evaporate before colliding the surface of condensers.

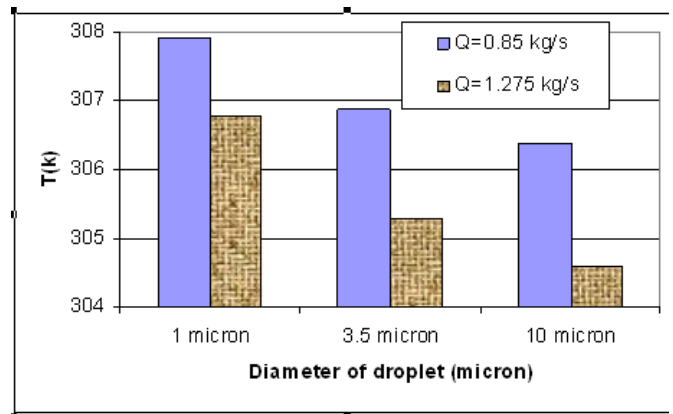

Fig.12 the effect of size of droplet with two different flow rates on mean temperature

V. CONCLUSION

In this paper, using numerical simulation of water droplet injection in an air condenser of a power plant, the effects of the arrangement of nozzles, water flow rate, diameters of droplets on temperature distribution and evaporation rate is investigated. Results show that with increasing the number of injecting nozzles a more uniform temperature distribution will be achieved. Temperature distribution is decreased linearly with increasing flow rate of water. Injecting droplets with diameter in the range of 1-10 microns will be a suitable range for injecting the droplets.

REFERENCES

- [1] Lam JC. Energy analysis of commercial buildings in subtropical climates. *Building and Environment* 2000;35:19–26.
- [2] Yik FWH, Burnett J, Prescott I. Predicting air-conditioning energy consumption of a group of buildings using different heat rejection methods. *Energy and Buildings* 2001;33:151–66.

- [3] Yu FW, Chan KT. Electricity end-use characteristics of air-cooled chillers in hotels in Hong Kong. *Building and Environment* 2005;40:143–51.
- [4] Chan KT, Yu FW. Applying condensing-temperature control in air-cooled reciprocating water chillers for energy efficiency. *Appl Energy* 2002;72:565–81.
- [5] Chan KT, Yu FW. Part-load efficiency of air-cooled multiple-chiller plant. *Building Services Eng Res Technol* 2002;23(1):31–41.
- [6] Lam JC. Energy analysis of commercial buildings in subtropical climates. *Building Environ* 2000;35:19–26.
- [7] Yik FWH, Burnett J, Prescott I. Predicting air-conditioning energy consumption of a group of buildings using different heat-rejection methods. *Energy Buildings* 2001;33:151–66.
- [8] B. E. Launder and D. B. Spalding. *Lectures in Mathematical Models of Turbulence*. Academic Press, London, England, 1972.