

# Transmission Cost Allocation in Restructured Power Systems Based on Nodal Pricing Approach by Controlling the Marginal Prices

M. Ghayeni\*, R. Ghazi\*

**Abstract:** This paper presents a method to allocate the transmission network costs to users based on nodal pricing approach by regulating the nodal prices from the marginal point to the new point. Transmission nodal pricing based on marginal prices is not able to produce enough revenue to recover the total transmission network costs. However, according to the previous studies in this context, this method recovers only a portion of transmission costs. To solve this problem, in this paper a method is presented in which by considering the direction and amount of injected power in each node the marginal price is regulated to the new price, in such a way as the nodal pricing can recover the total transmission network costs. Also the proposed method is able to control the cost splitting between loads and generators in accordance with the pre-specified ratio. The proposed method is implemented on both IEEE 24-bus and 118-bus test systems and the obtained results are reported.

**Keywords:** Transmission Cost Allocation, Marginal Pricing, Price Regulating, Injected Power.

## 1 Introduction

In deregulated electricity markets around the world, the transmission network is a regulated monopoly part. In this situation, the main purpose of transmission pricing is the calculation of the total transmission network cost (TNC) and then allocates it to network users. A transmission cost allocation (TCA) method should have some features such as: ability to recover the TNC, cost allocation in an equitable manner, simplicity in implementation, transparency for users, ability to increase the market efficiency in midterm and finally provision of economic signals for users to reduce the network usage in long term [1].

There are various methods to allocate the transmission costs among the network users in proportion to the extent of use. For example, Galiana et al. have presented equivalent bilateral exchange scheme [2], Conejo et al. have proposed Matrix impedance method [3], Oloomi and Salehizadeh have used the voltage angle decomposition method [4] and Bhakar et al. have employed the game theory to solve this problem [5]. Also various transmission usage cost allocation methods have been reviewed in some papers

[6-7]. Although these TCA methods can recover the TNC through a fair and equitable way but they are not able to provide appropriate economic signals to network users [8].

Nodal pricing is another approach which is based on the nodal price differences throughout the network and is currently developed worldwide. In this method, the network revenues are equal to the transmission rent (TR) and defined as the difference between what the loads pay and what the generators are paid. Marginal pricing is a nodal pricing method based on the locational marginal price (LMP) that provides the correct economic signals to loads, generators and system operators towards efficient use of the transmission network. However, the main drawback of this method is that by which the TR can not be equal to the TNC. In a special case of lossless network with no transmission congestion, the LMPs at all nodes are equal, so the TR becomes zero. However, even for a lossy network under transmission congestion, there is no guarantee that the TR could recover the TNC. Rubio-Oderiz and Arriaga have checked this fact in several systems around the world (Argentina, Chile, Central America, England and Wales, and Spain) and demonstrated that the maximum TR in these systems is only 25% of the TNC [9].

To solve this problem, there are two approaches: In one approach, at first the marginal pricing is performed

---

Iranian Journal of Electrical & Electronics Engineering, 2010.

Paper first received 20 Feb. 2010 and in revised form 23 May 2010.

\* The authors are with the Department of Electrical Engineering, Ferdowsi University of Mashhad, Mashhad, Iran.

E-mails: [mo\\_gh82@stu-mail.um.ac.ir](mailto:mo_gh82@stu-mail.um.ac.ir), [rghazi@um.ac.ir](mailto:rghazi@um.ac.ir)

and then the uncovered costs, i. e. the difference between the TNC and TR, as a complementary cost, is allocated to network users in terms of their extent of use of the network. Rubio-Oderiz and Arriaga have used this approach to allocate the complementary costs by the participation factor and the benefit factor methods [9]. Sedaghati has defined the critical capacity and then allocating the complementary costs by the modified benefit factor method [10]. Guo et al. have used the power tracing method to allocate the complementary costs to network users [11].

In the other approach, the LMPs can be adjusted to new nodal prices (NNPs) in such a way that the nodal pricing method could recover the TNC. To our knowledge, very little research work has been done based on this approach. However, Ref. [12] is the only published paper in which a comprehensive evaluation is carried out regarding this approach. In this reference the nodal prices are controlled to the new prices such that the TR becomes equal to the TNC and at the same time the sum of price deviation from marginal prices is minimized. In this reference, the load and the generator in each node is cleared with an equal price. Therefore, in those nodes in which the NNP is less than the LMP, loads pay less and therefore receive a credit and in those nodes in which the NNP is greater than the LMP, generators are paid more and so receive credit. Although these credits can provide correct economic signals, but can not be accepted by all market participants since some transmission users get credit instead of paying charge. It means that this imposes extra charge on some users. Also these credits cause more difference between NNPs and LMPs, because the other loads and generators must pay these credits in addition to TNC.

To solve this problem, in the present paper we propose that the generator and the load in each node to be cleared with different prices and in the calculation of TR, the direction of injected power to be noted. If the injected power is positive only the clearing price of generator is changed to the NNP but the load will pay the price based on the LMP. On the other hand, if the injected power is negative the clearing price for load is the regulated NNP but for the generator is the LMP based price. So with this modification, those users will make the contribution in reducing the network flows (loads in the positive injected nodes and generators in the negative injected nodes), instead of receiving a credit do not pay the transmission costs thereby the appropriate economic signals are provided. Therefore, this could lead to less variation in new prices than the method of [12].

The other topic in the TCA problem is how to split the TNC between generators and loads. The cost splitting ratio is different in various power markets. In some countries such as Germany, Spain, Belgium, Bulgaria, Hungary and Netherlands the total transmission costs are paid by loads. But in some

countries generators will contribute in the transmission costs, for example, in Norway the loads pay 65% and the generators pay 35% or in Australia the loads pay 85% and only 15% is paid by the generators regarding their market regulations [13]. This is an important issue, so the TCA algorithm could have the flexibility to consider any pre-specified cost splitting ratio. In [12] the developed TCA splits the TNC between generators and loads with 50/50 ratio; but, it can not work properly in cases where this ratio becomes 0/100 or 100/0. The reason for this drawback is that the load and the generator in each node are cleared with the same price. However, in the proposed method this disadvantage is eliminated and the NNPs are regulated in such a way that not only the TNC is recovered, but also the cost splitting between generators and loads is controlled in accordance with the pre-specified ratio.

The rest of the paper is organized as follows: In section 2, the calculation procedure of marginal transmission rent is formulated. Our proposed method of cost allocation based on nodal pricing with regulating the nodal price is explained and formulated in section 3. The presented approach is applied to IEEE 24-bus and 118-bus test systems as numerical examples and results are shown in section 4. The conclusions are given in section 5.

## 2 Marginal Transmission Rent

In nodal pricing approach the TR is defined as the difference between what the loads pay and what the generators are paid. If the TR is calculated by the LMPs, it will be termed as the Marginal TR. The LMP at each node is defined as the minimum marginal cost of supplying the next increment of load at that node without violations of any transmission limits. The LMPs are obtained within an optimal power flow (OPF) framework, as they are the dual variables (shadow prices) for the power balance equality constraints at nodes. In this paper, DCOPF is used to model the market and the generation bid is considered as an objective function to be minimized. Equality constraints include the active power balance equation at each node and inequality constraints are limits on line power flow and generation level. So DCOPF is formulated as follows:

$$\text{Min } \sum_{i=1}^{N_g} \rho_i(P_{g_i}) \quad (1)$$

subject to:

$$\sum_{j=1}^{N_b} B_{ij} \times (\delta_i - \delta_j) = P_{g_i} - P_{d_i} \quad i = 1, 2, \dots, N_b \quad (2)$$

$$P_{g_i}^{\min} \leq P_{g_i} \leq P_{g_i}^{\max} \quad i = 1, 2, \dots, N_g \quad (3)$$

$$P_i^{\min} \leq P_i = \left( \sum_{j=1}^{N_b} H_{ij} \times \delta_j \right) \leq P_i^{\max} \quad i=1,2,\dots,N_l \quad (4)$$

where,  $\rho_{gi}$  is the bid function of generation unit  $i$ ,  $P_{gi}$  and  $P_{di}$  are the generation and the consumption at node  $i$  respectively.  $N_b$ ,  $N_g$  and  $N_l$  are the number of nodes, generators and lines respectively and  $\delta_i$  is voltage angle of node  $i$ .  $B$  is the network susceptance matrix and  $H$  is the matrix relating voltage angles to lines flow.  $P_{gi}^{\max}$  and  $P_{gi}^{\min}$  are the generation limits of unit  $i$  and also  $P_l^{\max}$  and  $P_l^{\min}$  are the flow limits in line  $l$ .

After defining the Lagrange function, the Lagrange multipliers of the active power balance equations are calculated. These multipliers are the LMPs. The optimal generation level of unit  $i$  and voltage angle of node  $i$  are denoted by  $P_{gi}^*$  and  $\delta_i^*$  respectively. So the marginal transmission rent (MTR) is calculated by Eq. (5):

$$MTR = \sum_{i=1}^{N_b} (P_{di} - P_{gi}^*) \times LMP_i \quad (5)$$

The MTR can not recover the TNC. In a special case of lossless network with no transmission congestion, LMP at all nodes are equal and so the MTR becomes zero. However, even for a lossy network under transmission congestion, there is no guarantee that the TR could recover the TNC. Therefore, as our intention is to perform TCA by nodal pricing method, the nodal prices must be changed from the marginal points to the new points, so that the new TR could become equal to the TNC.

### 3 The Proposed Method of Cost Allocation

In the proposed method, the LMPs are regulated to the new nodal prices (NNPs) to recover the TNC provided that their variations to be minimized and also the cost splitting between loads and generators to be attained in accordance with a pre-specified ratio. To change the nodal prices, the objective function of OPF is modified by adding the penalty factors for both injected and generation power [12]. So the new objective function is given by Eq. (6):

$$\begin{aligned} \text{Min} \quad & \sum_{i=1}^{N_g} \rho_i (P_{gi}) + \sum_{i=1}^{N_b} (\rho_{\delta_i} \times \sum_{j=1}^{N_b} B_{ij} \times (\delta_i - \delta_j)) \\ & + \sum_{i=1}^{N_g} \rho_{gi} \times P_{gi} \end{aligned} \quad (6)$$

where  $\rho_{\delta_i}$  and  $\rho_{gi}$  are the penalty factors for injected power of node  $i$  and generation unit  $i$  respectively.

The presence of these penalties causes the Lagrange multipliers and thus the nodal prices to be varied. To control the NNPs in such a way that the TR becomes equal to the TNC regarding a predefined ratio associated with cost splitting, it is needed to define new constraints on NNPs. Of course the NNPs must satisfy the Kuhn-Tucker conditions with the new objective function of Eq. (6) and constraints in Eqs. (2)-(4) at the

optimal points obtained by the conventional OPF via Eqs. (1)-(4). These equations are derived in subsection 3.1.

The most important aspect of the proposed method is that it treats the generator and load in a node (NNP or LMP) with different clearing prices so causes the TR in each node to be dependent on the direction of injected power in that node. If the injected power is positive the clearing price of generator is changed to the NNP which is less than the LMP while the clearing price of load remains at LMP. Whereas if the injected power is negative the clearing price of load is regulated to the NNP which is greater than the LMP, but the generator clearing price remains at LMP. With this modification, those users making a reduction in the network flows will not pay transmission cost (loads in positive injected nodes and generators in negative injected nodes) and the TNC is allocated to the other users observing the minimum variation in NNPs. More detail and formulations are given in subsection 3.2. The procedure of cost splitting between loads and generators based on predefined ratio is also explained in subsection 3.3. Finally the complete formulation for calculating the NNPs and so determining the share of each generator and load in TNC is presented in subsection 3.4. The flowchart of the proposed method is also provided in this subsection.

#### 3.1 Kuhn–Tucker Conditions

The NNPs must satisfy the Kuhn–Tucker conditions associated with OPF formulation with the objective function given by Eq. (6) and the subjected constraints defined by Eqs. (2)-(4). For this purpose, the Lagrange function can be expressed by Eq. (7):

$$\begin{aligned} L = & \sum_{i=1}^{N_g} \rho_i (P_{gi}) + \sum_{i=1}^{N_b} (\rho_{\delta_i} \times \sum_{j=1}^{N_b} B_{ij} \times (\delta_i - \delta_j)) + \\ & \sum_{i=1}^{N_g} \rho_{gi} \times P_{gi} + \\ & \sum_{i=1}^{N_b} \left[ \lambda_i \times \left( \sum_{j=1}^{N_b} B_{ij} \times (\delta_i - \delta_j) - P_{gi} + P_{di} \right) \right] + \\ & \sum_{i=1}^{N_g} \sigma_{L_i} \times (P_{gi}^{\min} - P_{gi}) + \sum_{i=1}^{N_g} \sigma_{U_i} \times (P_{gi} - P_{gi}^{\max}) + \\ & \sum_{l=1}^{N_l} [\gamma_{L_l} \times (P_l^{\min} - \sum_{j=1}^{N_b} H_{lj} \times \delta_j)] + \\ & \sum_{l=1}^{N_l} [\gamma_{U_l} \times (\sum_{j=1}^{N_b} H_{lj} \times \delta_j - P_l^{\max})] \end{aligned} \quad (7)$$

where  $\lambda_i$  is the Lagrange multiplier associated with the power balance constraint in node  $i$  which is the  $NNP_i$ .  $\sigma_{L_i}$ ,  $\sigma_{U_i}$ ,  $\gamma_{L_l}$  and  $\gamma_{U_l}$  are the Lagrange multipliers related to lower & upper limits for generation unit  $i$  and transmission line  $l$  respectively. To satisfy the Kuhn–Tucker conditions the below equations are obtained:

$$\frac{\partial L}{\partial P_{gi}} = IC_{gi} + \rho_{gi} - \lambda_i - \sigma_{L_i} + \sigma_{U_i} = 0 \quad i=1,2,\dots,N_g \quad (8)$$

$$\frac{\partial L}{\partial \delta_j} = \sum_{i=1}^{N_b} [(\rho_{\delta_i} + \lambda_i) \times B_{ij}] + \sum_{i=1}^{N_l} [(\gamma_{U_i} - \gamma_{L_i}) \times H_{ij}] = 0 \quad (9)$$

for  $j = 1, 2, \dots, N_b$

$$\sum_{i=1}^{N_g} \sigma_{L_i} \times (P_{g_i} - P_{g_i}^{\min}) + \sum_{i=1}^{N_g} \sigma_{U_i} \times (P_{g_i}^{\max} - P_{g_i}) + \sum_{i=1}^{N_l} \gamma_{L_i} \times (P_i - P_i^{\min}) + \sum_{i=1}^{N_l} \gamma_{U_i} \times (P_i^{\max} - P_i) = 0 \quad (10)$$

$$\begin{cases} \sigma_{L_i} \geq 0, & \sigma_{U_i} \geq 0 & i = 1, 2, \dots, N_g \\ \gamma_{L_i} \geq 0, & \gamma_{U_i} \geq 0 & i = 1, 2, \dots, N_l \end{cases} \quad (11)$$

The NNPs must satisfy the above equations at the optimal points for  $P_g$  and  $P_l$  which are obtained from the conventional OPF in Eqs. (1)-(4).

### 3.2 New Formulation for Transmission Rent

In our method, the direction of price change at each node and then the calculation of TR is dependent on the direction of injected power in that node. In terms of power consumption and generation at each node, the system nodes are classified into three groups. If the consumption and generation of power at any node are equal, the injected power will be zero and so the loads and the generators are not using the transmission network to receive or deliver their power. Therefore, in these nodes the nodal prices are not changed, so they will not pay any cost for transmission.

In the second group, the generation at node is greater than the consumption, so in these nodes the surplus power is injected to the transmission network for supplying the other loads. This case is shown in Fig. 1.

From transmission network point of view, the generators in these nodes are using the transmission network to deliver the surplus of their powers to loads in other nodes, so in these nodes, the loads do not use the transmission network and should not pay any cost for transmission. But the generators have to be shared in the transmission costs proportional to their usage. So in these nodes, the loads are cleared with the LMP since they do not share in transmission costs but the generators are paid based on the NNP which is less than the LMP. Therefore, the transmission rent in the positive injected nodes is calculated by Eq. (12).

$$\text{if } P_{g_i} > P_{d_i} \Rightarrow \text{TR}_i = \text{LMP}_i \times P_{d_i} - \text{NNP}_i \times P_{g_i} \quad (12)$$

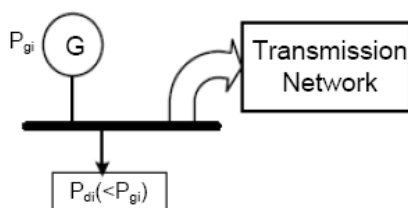

Fig. 1 Node  $i$  with positive injected power.

In the third group, the consumption is greater than the generation, so the injected power will be negative as shown in Fig. 2.

In these nodes, the loads are using the transmission network to provide their deficiency of powers from other nodes, so in such nodes, the generators do not use the transmission network and should not pay any cost for transmission. But the loads have to be shared in the transmission costs proportional to their usage. Therefore, generators in these nodes are cleared with the LMP since they do not share in transmission costs while loads pay based on the NNP which is greater than the LMP. So the transmission rent in the negative injected nodes is calculated by Eq. (13):

$$\text{if } P_{d_i} > P_{g_i} \Rightarrow \text{TR}_i = \text{NNP}_i \times P_{d_i} - \text{LMP}_i \times P_{g_i} \quad (13)$$

The NNPs are controlled so as the TR becomes equal to the TNC. The conditional Eqs. (12) and (13) are combined using a unit step function, so the TR is formulated by Eq. (14):

$$\text{TR} = \sum_{i=1}^{N_b} [(\text{NNP}_i \times P_{d_i} - \text{LMP}_i \times P_{g_i}) \times U(P_{d_i} - P_{g_i}) + (\text{LMP}_i \times P_{d_i} - \text{NNP}_i \times P_{g_i}) \times U(P_{g_i} - P_{d_i})] \quad (14)$$

where  $U(\cdot)$  is the unit step function.

### 3.3 Transmission Cost Splitting Between Loads and Generators

The other advantage of the proposed method is its flexibility to control the cost splitting between loads and generators in a pre-specified ratio. In various power markets, the share of loads/or generators in TNC can be varied from zero to hundred percent in accordance with the market regulation. Therefore, the TCA algorithm should be able to tackle this problem in a flexible way. In the proposed method, by considering the different clearing price for load and generator in each node (LMP or NNP), the full flexibility of cost splitting is obtained. Suppose that the share of the loads in the TNC is  $\alpha$  percent, so the NNPs must satisfy the Eq. (15).

$$\sum_{i=1}^{N_b} [(\text{NNP}_i - \text{LMP}_i) \times P_{d_i} \times U(P_{d_i} - P_{g_i})] = (\text{TNC} - \text{MTR}) \times \frac{\alpha}{100} \quad (15)$$

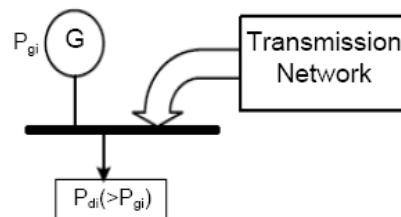

Fig. 2 Node  $i$  with negative injected power.

The unit step function in this equation implies that the clearing price of loads is only changed in nodes with negative injected power and also the changes are controlled to make the total load payment for transmission equal to  $\alpha$  percent of the TNC.

### 3.4 The Complete Formulation of the Proposed Method

In the previous sections, the constraints governing on the NNPs were proposed. In this section, the complete formulation for calculating the NNPs is presented and the share of each generator and load in TNC is thereby determined. It is clear that by changing the penalty factors, there exist some degrees of freedom to calculate the NNPs. In other words, there are some groups of NNPs which all can satisfy Eqs. (8)-(11) and (14)-(15). Therefore, according to some criteria the best group to be selected. To do this, an optimization problem is defined in which minimizing the variation of the NNPs from LMPs is considered as an objective function. The constraints of this optimization problem are all those to be satisfied in the process of obtaining NNPs. So the complete optimization problem for calculating the NNPs can be written as follows:

$$\text{Min } \sqrt{\sum_{i=1}^{N_b} (\text{NNP}_i - \text{LMP}_i)^2} \quad (16)$$

subject to:

$$\sum_{i=1}^{N_b} [(\text{NNP}_i \times P_{d_i} - \text{LMP}_i \times P_{g_i}^*) \times U(P_{d_i} - P_{g_i}^*) + (\text{LMP}_i \times P_{d_i} - \text{NNP}_i \times P_{g_i}^*) \times U(P_{g_i}^* - P_{d_i})] = \text{TNC} \quad (17)$$

$$\sum_{i=1}^{N_b} [(\text{NNP}_i - \text{LMP}_i) \times P_{d_i} \times U(P_{d_i} - P_{g_i}^*)] = (\text{TNC} - \text{MTR}) \times \frac{\alpha}{100} \quad (18)$$

$$\text{IC}_{g_i}^* + \rho_{g_i} - \text{NNP}_i - \sigma_{L_i} + \sigma_{U_i} = 0 \quad i = 1, 2, \dots, N_g \quad (19)$$

$$\sum_{i=1}^{N_b} [(\rho_{\delta_i} + \text{NNP}_i) \times B_{ij}] + \sum_{l=1}^{N_l} [(\gamma_{U_l} - \gamma_{L_l}) \times H_{lj}] = 0 \quad (20)$$

for  $j = 1, 2, \dots, N_b$

$$\sum_{i=1}^{N_g} \sigma_{L_i} \times (P_{g_i}^* - P_{g_i}^{\min}) + \sum_{i=1}^{N_g} \sigma_{U_i} \times (P_{g_i}^{\max} - P_{g_i}^*) + \sum_{i=1}^{N_l} \gamma_{L_i} \times (P_i^* - P_i^{\min}) + \sum_{i=1}^{N_l} \gamma_{U_i} \times (P_i^{\max} - P_i^*) = 0 \quad (21)$$

$$\begin{cases} \sigma_{L_i} \geq 0, & \sigma_{U_i} \geq 0 & i = 1, 2, \dots, N_g \\ \gamma_{L_i} \geq 0, & \gamma_{U_i} \geq 0 & i = 1, 2, \dots, N_l \end{cases} \quad (22)$$

This non-linear optimization problem is solved and the NNPs and other variables are found.

After calculation of NNPs, the share of each generator and load in transmission costs are determined by Eqs. (23) and (24), respectively.

$$\text{TCG}_i = (\text{LMP}_i - \text{NNP}_i) \times P_{g_i}^* \times U(P_{g_i}^* - P_{d_i}) \quad (23)$$

$$\text{TCL}_i = (\text{NNP}_i - \text{LMP}_i) \times P_{d_i} \times U(P_{d_i} - P_{g_i}^*) \quad (24)$$

where  $\text{TCG}_i$  and  $\text{TCL}_i$  are the contribution of generator and load from total transmission costs at node  $i$ . It is clear that, if the injected power is positive, the load in this node does not pay any cost for transmission while the generator will pay the transmission cost in proportional to the decrement of price in that node. For nodes with negative injected power, the loads have to pay the transmission cost in proportional to the increment of price in those nodes while the generators do not pay any cost for transmission. Finally the flowchart of our proposed method for TCA is shown in Fig. 3.

### 4 Simulation Results

In this section, we present the numerical results obtained from implementation of the proposed method on the test systems. The IEEE RTS 24-bus system is used to report the results in detail and the IEEE 118-bus system is used as a large system to show the validity of our proposed method.

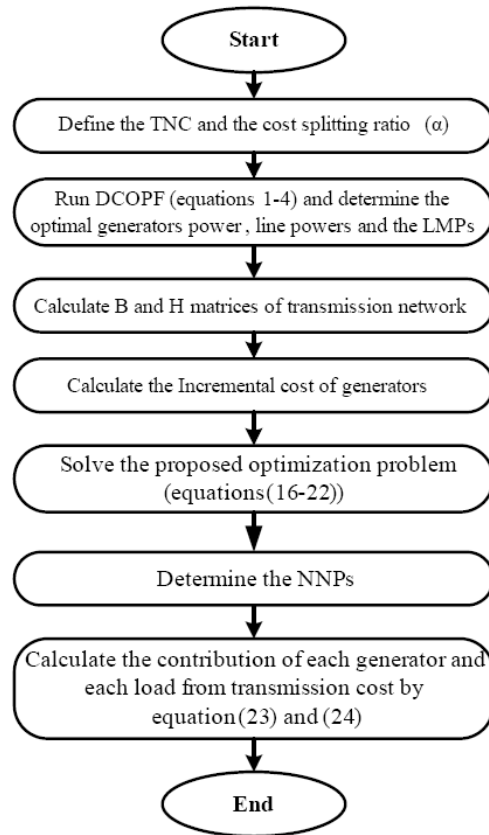

Fig. 3 Flowchart of the proposed method for TCA.

#### 4.1 IEEE RTS 24-Bus System

The single line diagram of this system is shown in Fig. 4. This network has two voltage levels, 138kV and 230 kV, as connected together via 5 transformers. The annual peak load of this system is 2850 MW and 580 MVAR which are dispatched at 18 nodes. Also there are 38 transmission lines and 32 generation units in 11 nodes with 3405 MW generation capacity [14]. The total transmission network costs (TNC) is equal to \$6513.5/h which consist of lines costs, substations costs and the operating cost of whole system (systemic costs) [12].

At first DCOPF is run and the generators power, lines power and the LMPs are determined. The LMPs in all nodes are the same and equal to \$21.07/MWh, as there is no congestion in the network and transmission losses are also negligible (DCOPF). Therefore, the MTR is zero and the total TNC to be allocated by means of price regulating. Now, after calculating B and H matrices and also the incremental cost of each generator, the proposed optimization problem i. e. Eqs. (16)-(22), is solved using the FMINCON developed program in MATLAB and the NNPs are found. Then the contribution of each generator and load from TNC is computed by Eqs. (23) and (24), respectively.

This procedure is performed for three different values of  $\alpha$ . In first case,  $\alpha$  is considered to be 50%, it means that the TNC is equally divided between loads and generators or split ratio of 50/50. The obtained NNPs for this case are plotted in Fig. 5.

In 24 bus test system, there are some nodes with no consumers and producers (11, 12, 17 and 24), so the injected powers at these nodes are zero, hence the price

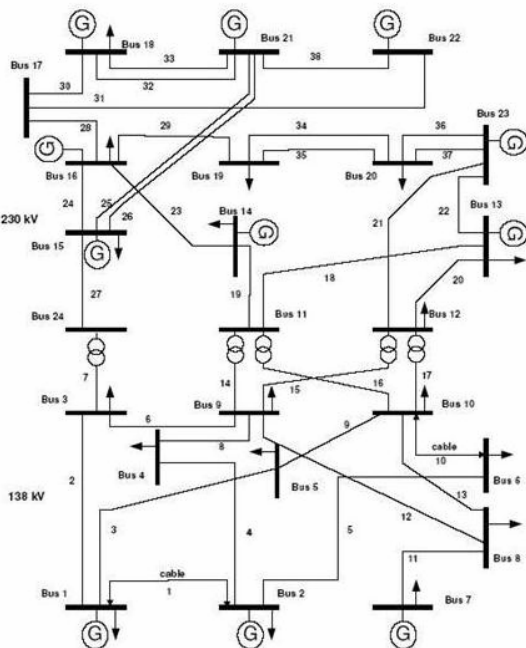

Fig. 4 Single line diagram of IEEE RTS 24-Bus System.

has not changed. In the positive injected nodes (1, 2, 7, 13, 18, 21, 22 and 23) the NNPs are decreased so that the sum of the transmission rent in these nodes recovers the half of TNC i. e. \$3256.75/h. The lowest price is at nodes 13 and 23 with \$19.45/MWh. In the negative injected nodes (3, 4, 5, 6, 8, 9, 10, 14, 15, 16, 19 and 20) the NNPs are increased such that the sum of the transmission rent in these nodes becomes equal to \$3256.75/h. The greatest NNP is \$23.97/MWh related to node 15.

In second case, we suppose that  $\alpha$  is equal to 100%. It means that the total TNC is paid by loads and generators make no contribution. The NNPs for this case are reported in Fig. 6. It can be observed that the NNPs are changed only in negative injected nodes and prices in other nodes remained at marginal prices. The maximum NNP is \$26.86/MWh at node 15. It is clear that the variation of prices in the negative injected nodes in this case is greater than the first case. The reason is that the TR obtained from these nodes must recover all amount of \$6513.5/h.

In third case,  $\alpha$  is equal to 0%, it means that the generators pay the total \$6513.5/h and loads make no contribution. The NNPs of this case is shown in Fig. 7.

It can be seen that the NNPs are changed only in the positive injected nodes and the prices in other nodes remained at marginal prices. The minimum NNP is \$17.83/MWh at nodes 13 and 23.

It should be noted that the program can be executed for any value of  $\alpha$ .

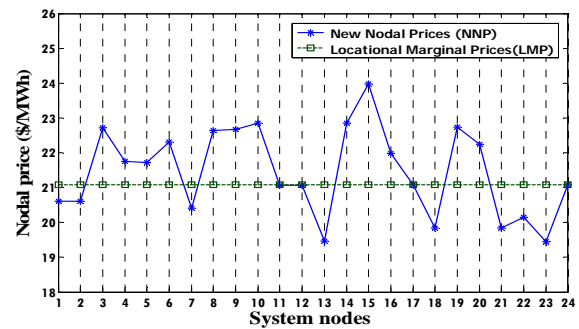

Fig. 5 The new nodal prices for  $\alpha=50\%$ .

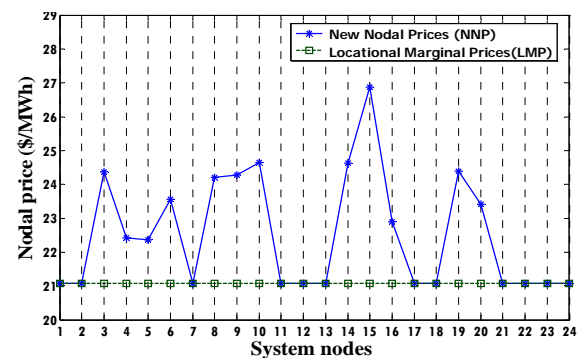

Fig. 6 The new nodal prices for  $\alpha=100\%$ .



Now, the contribution of each generator and load from transmission costs is computed using Eqs. (23) and (24). The results for three different values of  $\alpha$  are shown in Table1 and Table2 for loads & generators respectively.

The load in node 15 with 317MW consumption has the greatest contribution in transmission costs among loads, because the generation in this node is only 88.5MW and the deficiency of generation is provided by the transmission network. While the maximum consumption of system is 333MW at node18, but this load does not pay any cost for transmission, since there is 400MW generation in this node and load is supplied locally. Nodes 1, 2, 7 and 13 have the same situation. Therefore, if a load is located at a node, in which the generation is greater than the consumption, the load not only does not pay any cost for transmission but causes the transmission costs of the generator at that node to be reduced, because the injected power is decreased.

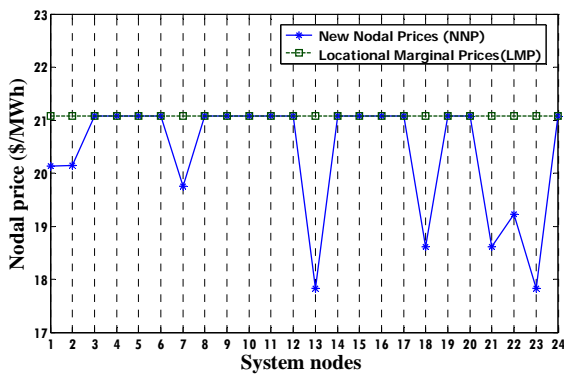

Fig. 7 The new nodal prices for  $\alpha=0\%$ .

Table 1 Loads contribution from transmission costs for different values of  $\alpha$ .

Load Bus Num	Pd (MW)	$\alpha=50$ percent		$\alpha=100$ percent		$\alpha=0$ percent	
		NNP (\$)	TCL (\$)	NNP (\$)	TCL (\$)	NNP (\$)	TCL (\$)
1	108	20.6	0	21.1	0	20.1	0
2	97	20.6	0	21.1	0	20.1	0
3	180	22.7	296	24.4	592	21.1	0
4	74	21.8	50	22.4	100	21.1	0
5	71	21.7	46	22.4	92	21.1	0
6	136	22.3	169	23.6	338	21.1	0
7	125	20.4	0	21.1	0	19.8	0
8	171	22.6	267	24.2	534	21.1	0
9	175	22.7	280	24.3	559	21.1	0
10	195	22.8	347	24.6	695	21.1	0
13	265	19.4	0	21.1	0	17.8	0
14	194	22.8	345	24.6	688	21.1	0
15	317	24.0	918	26.9	1836	21.1	0
16	100	22.0	91	22.9	182	21.1	0
18	333	19.8	0	21.1	0	18.6	0
19	181	22.7	299	24.4	599	21.1	0
20	128	22.2	150	23.4	299	21.1	0
Sum	2850	----	3256	----	6513	----	0

Table 2 shows the generators contribution in transmission costs. The generator at node 23 has the greatest contribution (\$857.26/h in  $\alpha=50\%$  case), because there is no local consumption at this node and generator must transmit 527MW generation to loads in other nodes. The generators in nodes 15 and 16 do not pay any cost for transmission since their generations are consumed locally. Therefore, if a generator is located at a node, in which the consumption is greater than the generation, the generator not only does not pay any cost for transmission but causes the contribution of load to be reduced, as the injected power is decreased.

Results shows that the proposed method provides financial incentive to loads and generators to locate at nodes making less use of network, so in long-term leading to a reduction in network expansion.

To be noted that, in [12], loads in the positive injected nodes and generators in the negative injected nodes receive credits because of their impacts in reducing the network usage. As these credits should be paid by other users, more variations on NNPs are pronounced. While in the proposed method by a new definition for TR, the economic signals are sent to users to encourage them to decrease the line flows. In addition, in our method these users do not pay transmission cost instead of receiving credits. Therefore, there is no need to be compensated by other users. So the nodal prices are changed in a way to recover only the TNC, and the variation of NNPs is thereby decreased in compare with the result of [12]. For further clarification, the NNPs of both methods are reported by different statistical indices in Table3.

Table 2 Generators contribution from transmission costs for different values of  $\alpha$ .

Gen. Bus Num.	Pg (MW)	$\alpha=50$		$\alpha=100$		$\alpha=0$	
		NNP (\$)	TCG (\$)	NNP (\$)	TCG (\$)	NNP (\$)	TCG (\$)
1	152	20.6	72	21.1	0	20.1	143
2	152	20.6	71	21.1	0	20.1	142
7	215	20.4	141	21.1	0	19.7	285
13	527	19.4	852	21.1	0	17.8	1710
15	88	24.0	0	26.9	0	21.1	0
16	88	22.0	0	22.9	0	21.1	0
18	400	19.8	493	21.1	0	18.6	985
21	400	19.8	493	21.1	0	18.6	985
22	300	20.2	277	21.1	0	19.2	554
23	527	19.4	857	21.1	0	17.8	1709
Sum	2850	-----	3256	-----	0	-----	6513

Table 3 Comparison between proposed method and Ref. [12]

Statistical indices	Ref. [12] method	Proposed method
Min NNP (\$/MWh)	17.72	19.45
Max NNP (\$/MWh)	23.60	23.97
Mean NNP (\$/MWh)	21.48	21.47
Std Deviation	1.45	1.253
Volatility (%)	6.77	5.84
MaxNNP-MinNNP	5.89	4.52

It can be seen that in our method the minimum NNP has decreased by \$1.73/MWh in compare with [12] and also the standard deviation of NNPs in our method is about \$0.2/MWh less than this index in [12]. The difference between Max and Min of NNPs in [12] is \$5.89/MWh, while this index has decreased to \$4.52/MWh in our method. Also the volatility index (defined as the ratio of the value of standard deviation to the average value) has decreased from 6.77% to 5.84%. These statistical indices show that the variation of NNPs in our method is less than that of [12]. So, it means that in our method the TNC is allocated to users with occurrence of minimum variations in the nodal prices.

Also the contribution of the loads and the generators in TNC can be compared in both methods. Table 4 shows the Maximum of TCG and TCL for both methods considering the different values of  $\alpha$ .

Results show that, when the allocation of TNC only to loads is intended, the method of [12] fails to do. This is obvious in case  $\alpha=100\%$  where the total TNC must be recovered only by loads, but some generators have contributed, while in our proposed method this contribution is zero. The similar situation can be seen in case  $\alpha=0\%$ . The reason is that the load and generator in each node are cleared with same price in [12], while in our proposed method, depending on the direction of injected power, load and generator are cleared with different prices (LMP or NNP). Hence the proposed method is quite flexible to control the cost splitting between loads and generators regarding any arbitrary predefined ratio (different values of  $\alpha$ ).

#### 4.2 IEEE 118 Bus System

Our proposed method is also implemented on IEEE 118-bus test system, so its validity for a large power system is also evaluated. This network comprises two voltage levels, 345kV with 12 buses and 11 lines and 138kV with 106 buses and 166 lines, as connected together via 9 transformers. This system has 54 generation units [15]. The TNC of this system with three different costs for lines corresponding to their voltage levels (138kv, 345kv and Trans.) is considered to be \$11261.12/h.

DCOPF is run for this system and the LMPs of all nodes are determined. The LMP of all nodes are the same and equal to \$39.38/MWh. Therefore, the total TNC is allocated by the nodal price regulating. The proposed method is then performed and the NNPs are obtained for two different values of  $\alpha=50\%$  and  $\alpha=100\%$ . The obtained results are shown in Figs. 8 and 9 respectively. The lowest NNP in case  $\alpha=50\%$  is \$37.25/MWh at node 89 and the highest is \$44.5/MWh at node 59 while the highest NNP in case  $\alpha=100\%$  is \$49.29/MWh.

The NNPs of 118 bus test system are obtained for both our method and method of [12] and reported in Table 5 using different statistical indices. Also in Table

6 the Maximum of TCG and TCL are reported for both methods for different values of  $\alpha$ . These results show that our method is able to allocate the TNC to the users with less variation of NNPs in compare with the method of [12].

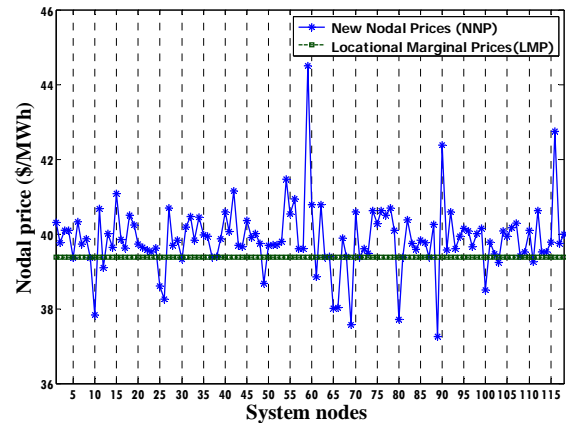

Fig. 8 The NNPs for  $\alpha=50\%$  in 118 bus system.

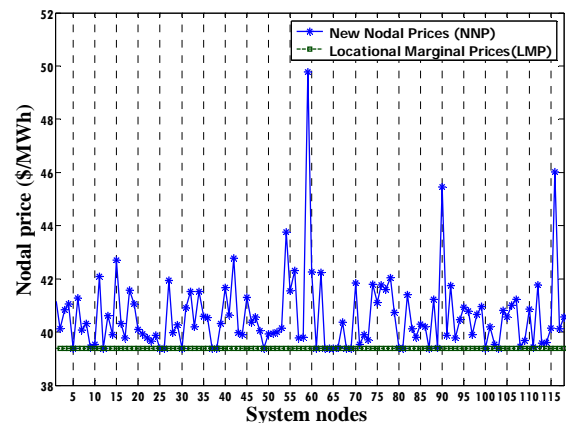

Fig. 9 The NNPs for  $\alpha=100\%$  in 118 bus system.

Table 4 Comparison of users' contribution in proposed method with Ref. [12].

contribution of users	$\alpha$	Ref. [12] method	Proposed method
Max TCG (\$/h)	100	1381	0
	50	1771.7	857.27
	0	2159.5	1709.6
Max TCL (\$/h)	100	1320.1	1835.6
	50	800.44	918.15
	0	281	0

Table 5 Comparison the proposed method with Ref. [12] for IEEE 118 bus test system.

Statistical indices	Ref. [12] method	Proposed method
Min NNP (\$/MWh)	36.24	37.25
Max NNP (\$/MWh)	44.00	44.50
Mean NNP(\$/MWh)	39.85	39.86
Std Deviation	0.984	0.909
Volatility (%)	4.052	4.387
MaxNNP-MinNNP	7.756	7.251



**Table 6** Comparison of maximum users' contribution in the proposed method with Ref. [12] for IEEE 118 bus test system.

contribution of users	$\alpha$	Ref. [12] method	Proposed method
Max TCG (\$/h)	100	1218.5	0
	50	1846.8	1255.4
	0	2629.1	2879.3
Max TCL (\$/h)	100	2482.8	2500.1
	50	1278.7	1417.2
	0	108.85	0

Results show that the proposed method is able to control the cost splitting ratio between loads and generators from zero to hundred percent in accordance with the market regulations. Also this method works properly for large power systems. As the number of constraints in optimization problem depends on node and generator number, so the simulation time is increased in large power systems. Of course, in further research work we try to present a suitable strategy for reducing the simulation time.

## 5 Conclusion

In this paper, a new method for TCA is presented based on the nodal pricing approach in which the nodal prices are controlled. In this method the nodal prices are regulated from marginal points to new points with minimum variations in such a way that the total transmission network costs to be recovered and also the cost splitting between loads and generators is realized in accordance with any predefined ratio. In our method the different clearing prices are assigned to load and generator in each node of concern. It means that for a positive injected node, the NNP which is less than the LMP will be the clearing price of generator while the LMP is for load. For a negative injected node, the NNP which is greater than the LMP is the load clearing price and the LMP is for generator. Results show that with this strategy, the variation of NNPs from LMPs is less in compare with other methods and also the cost splitting between loads and generators can be controlled from zero to hundred percent, dictated by market regulators.

Results show that in the proposed approach, the financial incentive is provided to loads and generators to locate at nodes leading to the reduction of injected power, so in long term the need for transmission network expansion is reduced. This method also provides appropriate economic signals to users for optimal selection of bilateral transactions. As users can easily calculate the transmission cost of contracts between two arbitrary nodes using the known nodal prices, a suitable decision making is provided then.

The presented method can be easily extended for pool-bilateral markets. Bilateral transactions are charged for network usage according to the difference of NNPs between the injecting and extracting nodes and

then the residual costs are allocated to other loads and generators in the pool market.

Finally, in this cost allocation approach the system cost is considered, whereas in other TCA methods, most often the cost of each line is allocated separately and the system cost received little attention.

## References

- [1] Olmos L. and Arriaga I. J. P. "A comprehensive approach for computation and implementation of efficient electricity transmission network charges," *Energy Policy*, Vol. 37, No. 12, pp. 5285-5295, Dec. 2009.
- [2] Galiana F. D., Conejo A. J. and Gil H. A., "Transmission network cost allocation based on equivalent bilateral exchanges," *IEEE Trans. Power Syst.*, Vol. 18, No. 4, pp. 1425-1431, Nov. 2003.
- [3] Conejo A. J., Contreras J., Lima D. A. and Feltrin A. P., "Zbus Transmission Network Cost Allocation," *IEEE Trans. Power Syst.*, Vol. 22, No. 1, pp. 342-349, Feb. 2007.
- [4] Oloomi-Buygi M. and Salehizadeh M. R., "Considering system non-linearity in transmission pricing," *Int. J. Elect. Power Energy Syst.*, Vol. 30, No. 8, pp. 455-461, Oct. 2008.
- [5] Bhakar R., Sriram V. S., Padhy N. P. and Gupta H. O., "Transmission Embedded Cost Allocation in Restructured Environment: A Game-theoretic Approach," *Elect. Power Compon. Syst.*, Vol. 37, No. 9, pp. 970-981, Dec. 2009.
- [6] Abou El Elaa A. A., El-Sehiemy R. A., "Transmission usage cost allocation schemes," *Elect. Power Syst. Res.*, Vol. 79, No. 6, pp. 926-936, June 2009.
- [7] Lima D. A., Feltrin A. P. and Contreras J., "An overview on network cost allocation methods," *Elect. Power Syst. Res.*, Vol. 79, No. 5, pp. 750-758, May 2009.
- [8] Arriaga I. J. P., Rubio F. J., Puerta J. F., Arceluz J. and Martín J., "Marginal pricing of transmission services: An analysis of cost recovery," *IEEE Trans. Power Syst.*, Vol. 10, No. 1, pp. 546-553, Feb. 1995.
- [9] Rubio-Oderiz F. J. and Arriaga I. J. P., "Marginal pricing of transmission services: A comparative analysis of network cost allocation methods," *IEEE Trans. Power Syst.*, Vol. 15, No. 1, pp. 448-454, Feb. 2000.
- [10] Sedaghati A., "Cost of Transmission System Usage Based on an Economic Measure," *IEEE Trans. Power Syst.*, Vol. 21, No. 2, pp. 446-473, May 2006.
- [11] Guo J., Wu Q. H., Turner D. R., Wu Z. X. and Zhou X. X., "Revenue Reconciliation for Spot Pricing: Implementation and Implication," *Elect. Power Compon. Syst.*, Vol. 32, No. 1, pp. 53-73, Jan. 2004.

- [12] Gil H. A., Galiana F. D. and da Silva E. L., "Nodal price control: A mechanism for transmission network cost allocation," *IEEE Trans. Power Syst.*, Vol. 21, No. 1, pp. 3–10, Feb. 2006.
- [13] ETSO Tariffs task force, *ETSO Overview of transmission tariffs in Europe: Synthesis 2007*, European Trans. Syst. Operators, June 2008.
- [14] IEEE PES Task force, "The IEEE Reliability Test System-1996," *IEEE Trans. Power Syst.*, Vol. 14, No. 3, pp. 1010-1020, Aug. 1999.
- [15] Christie R., University of Washington, Available at: <http://www.ee.washington.edu/research>.



**Mohsen Ghayeni** was born in Mashhad, Iran in 1980. He received the B.Sc. degree in electronic engineering and the M.Sc. degree in power engineering both from Ferdowsi University of Mashhad, Iran, in 2002 and 2006 respectively. He is currently a Ph.D. student at the Ferdowsi University of Mashhad. His research interests are power system operation,

power market and power quality.



**Reza Ghazi** (M'90) was born in Semnan, Iran in 1952. He received his B.Sc., degree (with honors) from Tehran University of Science and Technology, Tehran, Iran in 1976. In 1986 he received his M.Sc degree from Manchester University, Institute of Science and Technology (UMIST) and the Ph.D. degree in 1989 from University of Salford

UK, all in electrical engineering. Following receipt of the Ph.D. degree, he joined the faculty of engineering Ferdowsi University of Mashhad, Iran as an Assistant Professor of electrical engineering. He is currently Professor of Electrical Engineering in Ferdowsi University of Mashhad, Iran. His main research interests are reactive power control, FACTS devices, application of power electronic in power systems, distributed generation, restructured power systems control and analysis. He has published over 90 papers in these fields including three books.