

High performance DPC for PWM converters

Mohammad Monfared¹, Hasan Rastegar¹, and Hossein Madadi Kojabadi²

¹Dept. of Electrical Eng., Amirkabir University of Technology, Tehran, Iran
m.monfared@ieec.ac.ir, rastegar@aut.ac.ir

²Dept. of Electrical Eng., Sahand University of Technology, Tabriz, Iran
hmadadi64@yahoo.ca

Abstract

In this paper, direct power control (DPC) method for voltage source converters is described, then a high performance constant switching frequency DPC technique for three-phase pulse-width-modulated (PWM) converters is developed. Hysteresis comparators and switching table are replaced by a PWM modulator and the required converter voltage in each sampling period is directly calculated based on reference and measured values of reactive and active powers, system parameters, and the measured voltage of AC source. Then, the reference voltage is synthesized by the PWM block. In addition to a constant switching frequency, this method lets low sampling frequencies. Simulation results validate the superiority of the suggested DPC.

1. Introduction

A wide range of power electronics applications require the active and reactive power flows to be controlled somehow. Various control strategies for controlling the power flow of PWM voltage source converters are available. A well-known method of indirect active and reactive power control is based on the current vector orientation with respect to the line voltage vector called voltage-oriented control or VOC. The VOC guarantees high dynamics and static performance via internal current control loops. The scheme decouples the converter currents into active and reactive power components. Control of the active and reactive powers is then achieved by controlling the decoupled converter currents using current controllers. One main drawback of such a system is that the performance is highly dependent on the applied current control strategy and the connected AC network conditions [1]. Another control strategy called direct power control (DPC) is based on the instantaneous active and reactive power control. In DPC, there are no internal current control loops and no PWM modulator block, because the converter switching states are appropriately selected by a look-up table based on the instantaneous errors between the commanded and measured values of the active and reactive powers. Compared to the VOC, there is a simpler algorithm, no coordinate transformation and separate PWM voltage modulator, no need for decoupling between the control of the active and reactive components, and better static and dynamics performance. However, among the well-known disadvantages of the DPC scheme are [2-14]:

- variable switching frequency (difficulties of converter and filter design);
- high sampling frequency needed for digital implementation of hysteresis comparators;

- large inductance needed between the AC source and the converter;
- some problems due to the high gain of the hysteresis controllers.

In this research work a novel method for direct power control of three-phase pulse-width-modulated converters is presented. In this method hysteresis comparators and switching table are replaced by PWM voltage modulator. The required converter voltage in each sampling period is directly calculated based on only reference and measured values of reactive and active powers, system parameters, and the measured voltage of the AC source. Then, the PWM generator synthesizes the reference voltage and generates the switching pulses for the voltage source converter. Compared to the VOC, and conventional DPC there is a simpler algorithm, no current control loops, there is no need for decoupling between the control of active and reactive components, and finally, no hysteresis controllers are required. The proposed strategy besides having the conventional switching table based DPC method advantages, offers many unique features such as fixed and low switching frequency, low sampling frequency for digital implementation, simple and easy real time implementation, no hysteresis controller and linear PI controller, and the small inductance between the AC source and the converter.

2. Conventional DPC

Fig. 1 shows the configuration of the direct instantaneous active and reactive power controller for the PWM converter. Direct power control is based on the instantaneous active and reactive power control loops [2, 3].

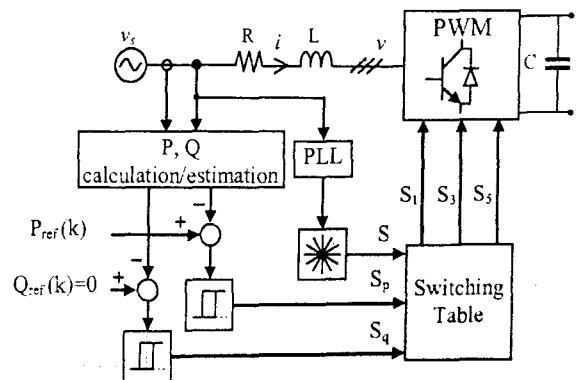

Fig. 1. Block diagram of the conventional DPC.

With DPC there are no internal current control loops and no PWM modulator block, because the converter switching states, in each sampling period, are selected from a switching table

based on the instantaneous errors between the commanded and measured or estimated values of active and reactive powers, and the angular position of the source voltage vector. In this configuration, usually, the DC link voltage is regulated by controlling the active power, and the unity power factor operation is achieved by controlling the reactive power to be zero. The DPC idea has been proposed by Ohnishi [2]. For the first time he used the instantaneous active and reactive power values as control variables instead of instantaneous three phase line currents ever used. He established first a proportional relationship between the instantaneous power values and the currents expressed in the rotational reference frame which only holds for the balanced sinusoidal operation. Since the converter voltage is related to the time derivatives of the line currents, so there is a relationship between the injected converter voltage and the time derivatives of the instantaneous active and reactive powers. Thus, the reference voltage for the PWM block is proposed in such a way that the sign of these derivatives opposes the sign of the errors in the active and reactive powers. For this purpose, hysteresis controllers are utilized which are simple and have a high gain. Because this method still needs a PWM block, so it cannot yet be considered as direct, however the principle of DPC is based on the Ohnishi's idea. The term "Direct Power Control" or DPC for the first time was used by Noguchi, *et al* for the control scheme depicted in Fig. 1 [3]. This method is based on selecting a voltage vector from a look-up table, Table 1, according to the errors of active and reactive powers as well as the angular position of the source voltage vector. The entries of the table which hereafter named the switching table was determined in order to minimize the errors between the commanded and measured or estimated powers in each sampling period. Also to achieve a better performance, they proposed to divide the vector space into twelve sectors and then determine the position of the source voltage vector accordingly.

Table 1. Switching table for DPC.

		S											
Sp	Sq	1	2	3	4	5	6	7	8	9	10	11	12
0	0	101	100	100	110	110	010	010	011	011	001	001	101
1	0	101	111	100	000	110	111	010	000	011	111	001	000
0	1	100	110	110	010	010	011	011	001	001	101	101	100
1	1	111	111	000	000	111	111	000	000	111	111	000	000

The most significant drawback of the DPC is the variable switching frequency which mainly depends on the sampling frequency, the switching table structure, system parameters, reference values of the active and reactive powers, hysteresis bands, and finally the converter switching status. This variable switching frequency will produce a broadband harmonic spectrum in the AC line currents. Because of these harmonics the design of filters will be difficult. On the other hand, DPC controllers are hysteresis type. These controllers cannot guarantee the perfect tracking of a time varying signal, unless arbitrarily high sampling/switching frequencies are used. Besides, due to their high gain, they are too much sensitive to current ripples which may disturb the control. So, in order to achieve an acceptable performance, large values for the sampling frequency and the filter inductance should be selected to attenuate the current ripples. Large inductance value leads to increased cost, dimensions, weight, and losses, and also reduces

the system dynamics. Above mentioned problems can be eliminated by avoiding the hysteresis controllers and also introducing a Space Vector Modulator (SVM) in control strategy [4-8]. In this method hysteresis comparators and switching table are replaced by linear PI controllers and SVM. The main drawback for such system is that the performance is highly dependent on the tuning of the PI controller. Rodriguez *et al* proposed a new strategy that eliminates the hysteresis controllers and switching table [9, 10]. A predictive DPC is presented in their work for the control of the AC/DC/AC converter. In the proposed control strategy, the finite possible switching states of the AC/DC/AC are considered, the effect of each one on the load current and input power is evaluated, and the switching state that minimizes a quality function is selected and applied during the next sampling period. The quality function evaluates the load current error for the inverter, and the input active and reactive power errors for the rectifier. Restrepo *et al* conducted a similar work in which the quality function minimizes the active and reactive power errors [11, 12]. Predictive approaches have also been employed in order to overcome the variable switching frequency problem of the DPC strategy [13, 14]. Instead of selecting an instantaneous optimal voltage vector, these approaches select an optimal set of concatenated voltage vectors, which is the so-called "voltage-vectors' sequence." The control problem is solved by computing the application times of the sequence vectors in such a way that the controlled variables converge toward the reference values along a fixed predefined switching period. In this way, constant switching frequency operation is obtained. Several authors have developed this concept in multilevel converter topologies linked to different kind of machines, but there are few predictive control applications on line-connected VSC systems. They called their proposed method P-DPC. Unfortunately, these methods require complex computation intensive and may not be viable in industrial applications. Also their performance is highly sensitive to system parameters.

3. Proposed DPC

The authors propose a new method to direct power control of three phase PWM converters that has the following advantages:

- no hysteresis controller and linear PI controller are required and reference values in each sampling period are directly computed based on measurements and system parameters;
- decoupled control of active and reactive powers;
- no need for evaluation of any quality function or any other optimization which are time consuming computations;
- fast calculation of reference voltage value for the modulator by using simple mathematical operations such as plus, minus, multiplication, and division;
- simple algorithm besides strong theoretical background;
- it operates at constant switching frequency thanks to the PWM generator, which makes the use of advanced modulation techniques possible;
- filter design is simple because of the constant switching frequencies and smaller inductance values thanks to the elimination of the hysteresis controllers;
- low switching and sampling frequency;
- higher dynamic behavior due to lower inductance values and fast control strategy.

Fig. 2 shows the block diagram of the proposed method. In this configuration, the reference value of the active power usually comes from the dc-link voltage regulator, and the unity power factor operation is achieved by controlling the reactive power to be zero.

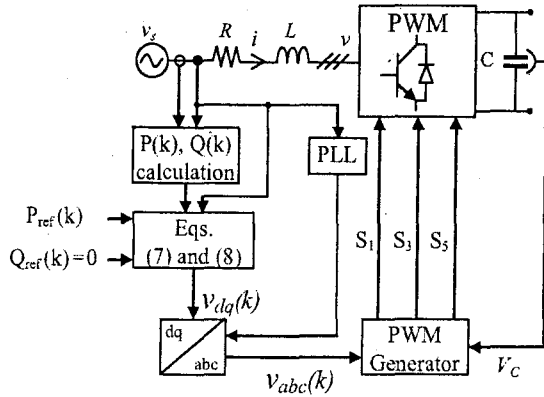

Fig. 2. Block diagram of the proposed DPC.

The following equations describe the system of Fig. 2:

$$L \frac{d}{dt} \begin{bmatrix} i_a \\ i_b \\ i_c \end{bmatrix} = -R \begin{bmatrix} i_a \\ i_b \\ i_c \end{bmatrix} + \begin{bmatrix} v_{sa} \\ v_{sb} \\ v_{sc} \end{bmatrix} - \begin{bmatrix} v_a \\ v_b \\ v_c \end{bmatrix} \quad (1)$$

where v is the converter voltage, v_s is the AC source voltage, i is the line current, R , and L are equivalent resistance and inductance between the source and the converter, respectively. By applying the Park transformation in the stationary reference frame to (1), then we will obtain:

$$L \frac{d}{dt} \bar{i}_{\alpha\beta} = -R \bar{i}_{\alpha\beta} + \bar{v}_{s\alpha\beta} - \bar{v}_{\alpha\beta} \quad (2)$$

Considering ω as the angular speed of the AC source voltage, (2) will change to (3) in the rotating reference frame.

$$\frac{d}{dt} \bar{i}_{dq} = \left(-\frac{R}{L} - j\omega \right) \bar{i}_{dq} + \frac{1}{L} \bar{v}_{sdq} - \frac{1}{L} \bar{v}_{dq} \quad (3)$$

By applying $d/dt(\bar{i}_{dq}) = (\bar{i}_{dq}(k+1) - \bar{i}_{dq}(k))/T_{sp}$ in each small sampling period (T_{sp}) to previous equation and decoupling the result to d and q components, equations set (4) will be obtained.

$$\begin{aligned} i_d(k+1) &= \left(1 - \frac{T_{sp}R}{L} \right) i_d(k) + T_{sp}\omega i_q(k) + \frac{T_{sp}}{L} (v_{sd}(k) - v_d(k)) \\ i_q(k+1) &= \left(1 - \frac{T_{sp}R}{L} \right) i_q(k) - T_{sp}\omega i_d(k) + \frac{T_{sp}}{L} (v_{sq}(k) - v_q(k)) \end{aligned} \quad (4)$$

On the other hand, the active and reactive powers in the rotating reference frame are:

$$\begin{aligned} P(k+1) &= v_{sd}(k+1) i_d(k+1) + v_{sq}(k+1) i_q(k+1) \\ Q(k+1) &= v_{sd}(k+1) i_q(k+1) - v_{sq}(k+1) i_d(k+1) \end{aligned} \quad (5)$$

Assuming that during a small sampling period, the AC source voltage is constant and substituting from (4) in (5) will lead to the following equations set for the instantaneous powers:

$$\begin{aligned} P(k+1) &= \left(1 - \frac{T_{sp}R}{L} \right) P(k) - T_{sp}\omega Q(k) \\ &\quad + \frac{T_{sp}}{L} (v_{sd}^2(k) + v_{sq}^2(k) - v_{sd}(k)v_d(k) - v_{sq}(k)v_q(k)) \\ Q(k+1) &= \left(1 - \frac{T_{sp}R}{L} \right) Q(k) + T_{sp}\omega P(k) \\ &\quad + \frac{T_{sp}}{L} (v_{sd}(k)v_q(k) - v_{sq}(k)v_d(k)) \end{aligned} \quad (6)$$

Controller must make the load active and reactive powers at the sampling point $(k+1)$, equal to the reference active and reactive power values currently available at the sampling point (k) , i.e. $P(k+1) = P_{ref}(k)$ and $Q(k+1) = Q_{ref}(k)$.

Using these two assumptions, we can solve the equations set (6) for $v_d(k)$ and $v_q(k)$. Also, in order to achieve a unity power factor the reactive power is assumed to be zero ($Q_{ref}(k) = 0$). Besides, by using a PLL, the control system will be synchronized with the AC source voltage and the quadrant component of the source voltage will be zero ($v_{sq}(k) = 0$), so we get the following simplified equations:

$$v_d(k) = v_{sd}(k) + \left(\frac{L}{T_{sp}} - R \right) \frac{P(k)}{v_{sd}(k)} - \frac{L}{T_{sp}} \frac{P_{ref}(k)}{v_{sd}(k)} - L\omega \frac{Q(k)}{v_{sd}(k)} \quad (7)$$

$$v_q(k) = - \left(\frac{L}{T_{sp}} - R \right) \frac{Q(k)}{v_{sd}(k)} - L\omega \frac{P(k)}{v_{sd}(k)} \quad (8)$$

Equations (7) and (8) show that the dq components of the converter voltage can be directly controlled according to only the reference and measured values of the active and reactive powers, system parameters, and the measured voltage of the AC source. The gating signals of the PWM converter will then be produced according to these dq voltage components.

In the proposed strategy, the voltage modulator has the dominant dynamics and the controller can almost reach the maximum system dynamic response. Since in the proposed DPC, in spite of the conventional one which is usually called switching table based DPC (STB-DPC), the hysteresis controllers are eliminated, so the problems of their high gain have been avoided. For example, the control sensitivity to AC current ripples is minimized and consequently the switching and sampling frequencies as well as the inductance value between the AC source and the converter can be chosen to be small. Furthermore, in the proposed DPC, the gate signals are generated by a PWM modulator instead of the hysteresis regulators, so the switching frequency is constant and much lower than the STB-DPC case, and also advanced modulation techniques can be used to achieve higher efficiencies and better harmonics performance.

4. Simulation Results

In order to verify the effectiveness of the proposed configuration and its control strategy, a digital computer simulation model has been developed in MATLAB/SIMULINK platform. The system parameters are summarized in Table 2.

Table 2. Simulated system parameters.

Input inductance L	10 mH
Input resistance R	200 m Ω
DC bus capacitor C	470 μ F
Source phase voltage v_s	70 V _{peak}
Source voltage frequency f_s	50 Hz
DC bus voltage E	150 V
Sampling frequency	10 kHz
Carrier frequency for SPWM generation	\approx 4 kHz

In order to evaluate the system performance, extensive simulations have been done based on the proposed strategy in steady-state and transient conditions. The validity of the proposed system will be verified by simulation results and will be compared with the simulation results of the conventional Switching Table Based-DPC (STB-DPC). Fig. 3 shows the steady-state response of both STB-DPC and proposed DPC schemes. These waveforms from STB-DPC and proposed DPC schemes confirm the superiority of the proposed method in providing more precise current control with minimum distortion and less harmonic noises (THD) and at the same time, more accurate regulation and less distortion in the output active and reactive powers. The total harmonic distortion (THD_i) for the proposed method is found 1.8%, whereas this value for the STB-DPC is 4.4%. Fig. 4 shows the transient response of both STB-DPC and proposed DPC schemes. At $t = 0.055$ s the reference value of the active power stepped up to 1500 W. Fig. 4-a shows that the measured value of the active power converges to the reference value in 0.001 s whereas this time for the STB-DPC is around 0.003 s as shown in Fig. 4-b.

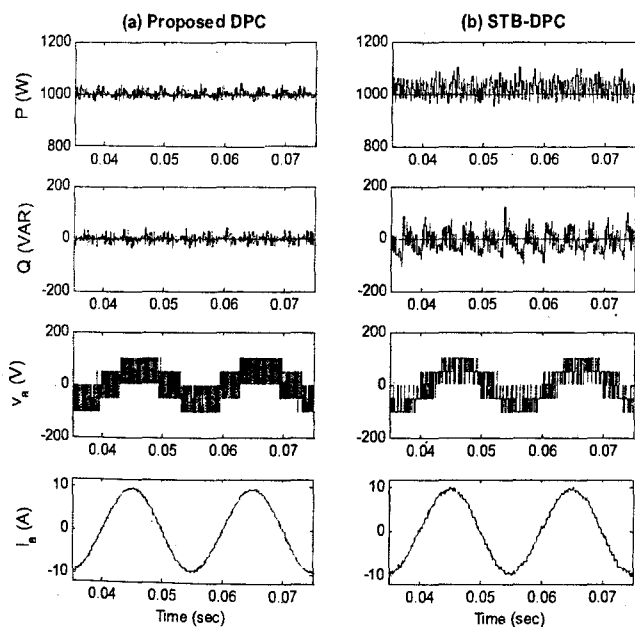

Fig. 3. Simulated waveforms for steady-state operation.

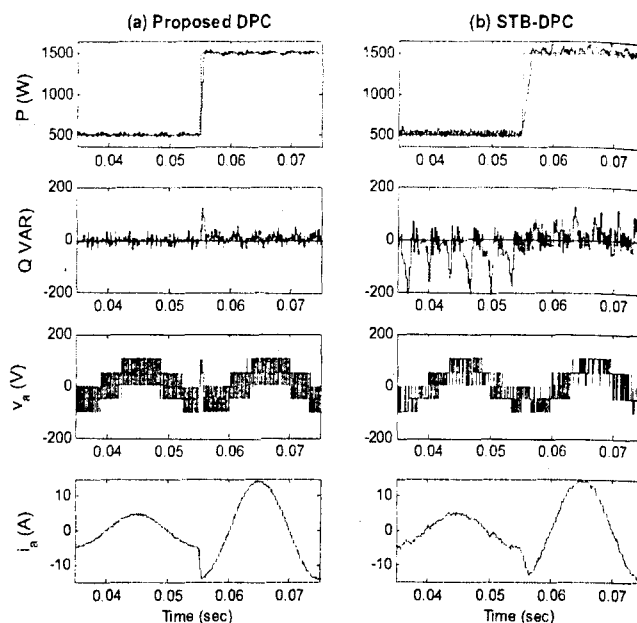

Fig. 4. Simulated waveforms for step change of active power.

The harmonic spectrum of the phase current i_a is shown in Fig. 5. One can recognize that the conventional DPC in Fig. 5-b has broadband harmonic spectrum that spread over a wide low frequency range. Because of these low frequency harmonics the design of filters will be difficult in order to avoid possible grid resonances.

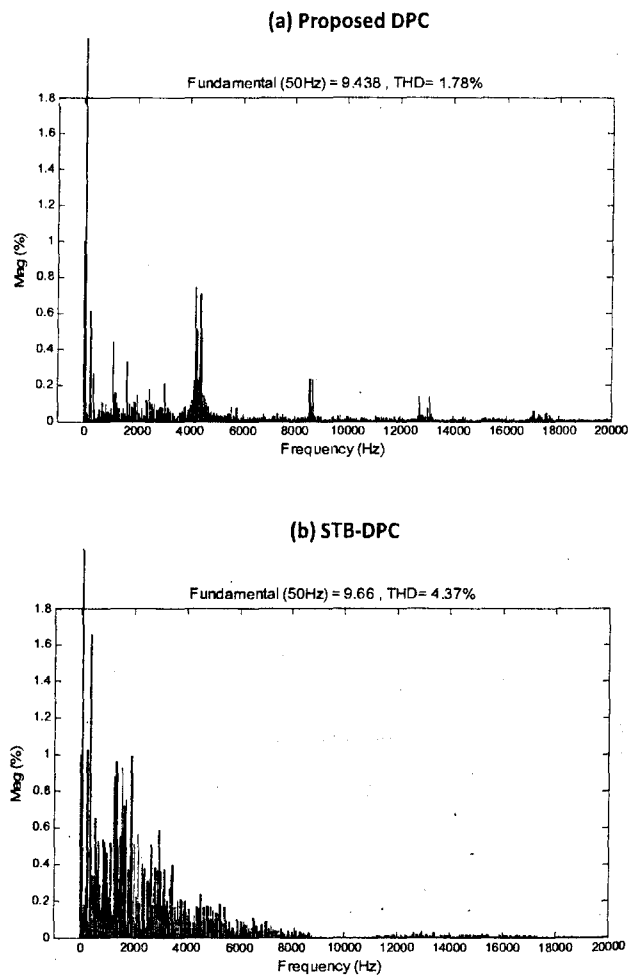

Fig. 5. Simulated line current harmonic spectrum ($P_{ref} = 1000$ W, $Q_{ref} = 0$)

5. Conclusions

A high performance constant switching frequency direct power control (DPC) of three-phase pulse-width-modulated (PWM) converters is presented. In this method hysteresis comparators and switching table are replaced by PWM modulator. Extensive simulations confirm the superiority of the proposed method in providing more precise power control with minimum distortion and harmonic noises (THDi), and at the same time, less distortion in active and reactive powers and narrower current harmonic spectrum in compare to conventional DPC scheme. The switching frequency is fixed; also it requires less sampling and switching frequencies and inductance value because of simpler and more precise algorithm which eliminates the hysteresis controllers.

6. Acknowledgment

The authors gratefully acknowledge the financial support of Iranian National Elite Foundation.

7. References

- [1] S. Buso, and P. Mattavelli, "Digital control in power electronics", Morgan & Claypool, USA, 2006.
- [2] T. Ohnishi, "Three phase PWM converter/inverter by means of instantaneous active and reactive power control", in *International Conference on Industrial Electronics, Control and Instrumentation*, 1991, pp. 819-824.
- [3] T. Noguchi, H. Tomiki, S. Kondo, and I. Takahashi, "Direct power control of PWM converter without power-source voltage sensors", *IEEE Trans. Ind. Applicat.*, vol. 34, no. 3, pp. 473-479, May/Jun., 1998.
- [4] M. Cichowlas, M. Malinowski, M. P. Kazmierkowski, D. L. Sobczuk, P. Rodriguez, and J. Pou, "Active filtering function of three-phase PWM boost rectifier under different line voltage conditions", *IEEE Trans. Ind. Electron.*, vol. 52, no. 2, pp. 410-419, Apr., 2005.
- [5] M. Jasinski, D. Swierczynski, and M. P. Kazmierkowski, "Novel sensorless direct power and torque control of space vector modulated AC/DC/AC converter", in *International Symposium on Industrial Electronics*, 2004, pp. 1147-1152.
- [6] M. Malinowski, M. Jasinski, and M. P. Kazmierkowski, "Simple direct power control of three-phase PWM rectifier using space-vector modulation (DPC-SVM)", *IEEE Trans. Ind. Electron.*, vol. 51, no. 2, pp. 447-454, Apr., 2004.
- [7] M. Cichowlas, M. Malinowski, and F. Blaabjerg, "Direct power control for three-phase PWM rectifier with active filtering function", in *Eighteen Annual IEEE Applied Power Electronics Conference and Exposition*, 2003, pp. 913-918.
- [8] M. Malinowski, and M. P. Kazmierkowski, "DSP implementation of direct power control with constant switching frequency for three-phase PWM rectifiers", in *28th Annual Conference of the Industrial Electronics Society*, 2002, pp. 198-203.
- [9] J. Rodriguez, J. Pontt, P. Correa, P. Lezana, and P. Cortes, "Predictive power control of an AC/DC/AC converter", in *Industry Applications Conference*, 2005, pp. 934-939.
- [10] P. Cortes, J. Rodriguez, P. Antoniewicz, and M. Kazmierkowski, "Direct power control of an AFE using predictive control", *IEEE Trans. Power Electron.*, vol. 23, no. 5, pp. 2516-2523, Sept., 2008.
- [11] J. Restrepo, J. Viola, J. M. Aller, and A. Bueno, "A simple switch selection state for SVM direct power control", in *IEEE International Symposium on Industrial Electronics*, 2006, pp. 1112-1116.
- [12] J. Restrepo, J. C. Viola, J. M. Aller, and A. Bueno, "Algorithm evaluation for the optimal selection of the space vector voltage using DPC in power systems", in *European Conference on Power Electronics and Applications*, 2007, pp. 1-9.
- [13] S. A. Larrinaga, M. A. R. Vidal, E. Oyarbide, and J. R. T. Apraiz, "Predictive control strategy for DC/AC converters based on direct power control", *IEEE Trans. Ind. Electron.*, vol. 54, no. 3, pp. 1261-1271, Jun., 2007.
- [14] P. Antoniewicz, M. P. Kazmierkowski, S. Aurtenechea, and M. A. Rodriguez, "Comparative study of two predictive direct power control algorithms for three-phase AC/DC converters", in *Proc European Conference on Power Electronics and Applications*, 2007, pp. 1-10.