

Comparison Between Communication Infrastructures of Centralized and Decentralized Wide Area Measurement Systems

Mohammad Shahraeini, *Student Member, IEEE*, Mohammad Hossein Javidi, and Mohammad Sadegh Ghazizadeh

Abstract—Restructuring in power systems has introduced new complexities and difficulties in controlling of these systems. Therefore, new control strategies should be investigated in operation of power systems. On the other hand, communication infrastructure (CI) is responsible for establishing any control strategy. The purposes of this study are twofold: firstly, to design a communication infrastructure for any given power network with determined measurements; secondly, to compare communication infrastructures for centralized and decentralized control strategies in power grids. The comparison criteria are communication network cost, delay (latency), and reliability. In this study, hybrid state estimation (HSE), as one of the most important wide area measurement systems (WAMS), is opted. Communication infrastructures are designed for two different control strategies; centralized and decentralized (multi-area) HSE. These strategies have been investigated in IEEE 118-bus test network. Some new concepts, that help us to compare any two given communication infrastructures with each other, are introduced. Finally, two designed communication infrastructures for these two strategies are compared with each other. The results show that, although communication infrastructure investments are almost the same in both cases, decentralizing, as a cause of decentralized control strategy, results in improvement of latency and reliability of CI.

Index Terms—Centralized and decentralized control strategies, communication delay and reliability, hybrid state estimation, power system communication infrastructure.

I. INTRODUCTION

RAPID GROWTH in power grids and competitive conditions in restructured power industries cause complexities and difficulties in controlling of these systems. As a result, system operators should consider new control strategies. Different strategies exist for controlling power system; two important ones are centralized and decentralized control strategies [1]. The information flow through communication infrastructure among different entities defines the type of system control. Control strategies are determined by locations of acquiring data (which are known as data resources), decision making location

(which is known as control center) and the devices by them actions are performed (which are known as controllable devices) [1], [2].

Communication infrastructure (CI) is responsible for data exchange among data resources, control centers, and controllable devices. Consequently, CI is an essential part of wide-area monitoring system (WAMS), wide-area protection system (WAPS), and wide-area control system (WACS) in power systems. These three types of systems have different response-time requirements, various data volume exchanging, and different priorities. Hence, they are characterized by different latency, bandwidth, reliability, and investment [3].

Considering prementioned facts, it can be concluded that to control new competitive electrical infrastructure securely, a CI should be established in the entire system [2], [4]. In addition to necessity of establishing CI in entire system, this infrastructure should have special characteristics such as bandwidth, latency, and reliability for accommodative operation.

This paper, for the first time, investigates two critical communication characteristics; latency and reliability, for centralized and decentralized control strategies in power systems. To carry out this investigation, communication networks with minimum lengths are designed for both cases. These minimum communication networks are considered as communication backbone networks of these systems. To compare CIs in these two systems, new indices have been proposed. Using these indices, centralized and decentralized backbone networks are compared with each other.

This paper is organized as follows. Section II defines power system control; reviews control strategies, control functions, and communication systems in power industries. The problem is defined and formulated in Section III. New indices related to communication latency and reliability are defined. Section IV represents optimization approach and simulation results. Finally, the paper ends with concluding remarks in Section V.

II. POWER SYSTEM CONTROL

Power system control includes the application of control theory and technology, optimization methodologies, and intelligent systems to improve the operation of power systems during normal and abnormal conditions [5]. Generally, a control process can be divided into five actions:

- Action1: Data are acquired from data resources;
- Action2: Measured data are transmitted to control center through “measuring communication system”;

Manuscript received September 18, 2010; accepted October 27, 2010. Date of publication December 17, 2010; date of current version February 18, 2011. Paper TSG-00132-2010.

M. Shahraeini and M. H. Javidi are with the Department of Electrical Engineering, Ferdowsi University of Mashhad, Mashhad, Iran (e-mail: m.shahraeini@meedc.net; h-javidi@ferdowsi.um.ac.ir).

M. S. Ghazizadeh is with the Department of Electrical Engineering, Power and Water University of Technology, Tehran, Iran (e-mail: ghazizadeh@pwut.ac.ir).

Color versions of one or more of the figures in this paper are available online at <http://ieeexplore.ieee.org>.

Digital Object Identifier 10.1109/TSG.2010.2091431

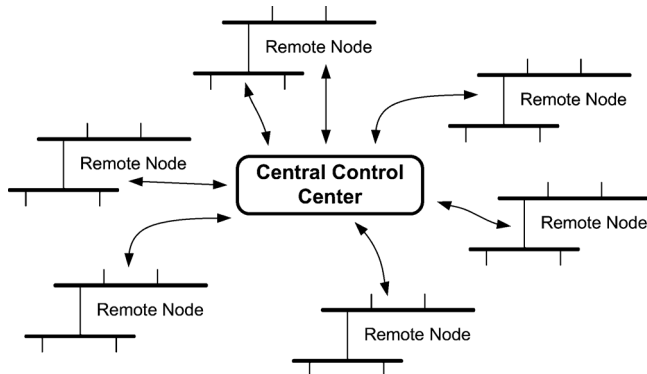

Fig. 1. Centralized control strategy.

- Action3: Decisions are made with this data and information;
- Action4: Control commands are sent to controllable devices through “controlling communication system”;
- Action5: Transmitted commands are run by controllable devices.

The first action is performed by data resources, which sometimes are known as measuring devices. Phasor measurement units (PMUs), power flow-injection measurement, and voltage magnitude metering devices are some examples of data resources.

The second and fourth actions use CI to exchange data among different entities. Traditionally, CI used for measuring data may be different from CI used for control commands [2]. Nowadays, new communication systems have some new features such that the communication network can be divided into multiple logical networks. Virtual local area networks (VLANs), virtual private networks (VPNs), and multiprotocol label switching (MPLS) are examples of some communication protocols used in power systems.

The next three subsections focus on “control strategies,” which denote the information flow among different actions; “functions of control centers,” which include third action; and “communication system,” which is used by second and fourth actions.

A. Control Strategies

As explained before, we have considered two types of control strategies applied in power systems. The control strategies are characterized by information flow among data resources, control center(s), and controllable devices [2].

In centralized control strategy, all data resources send data to a central control center (CCC). After processing the received data, appropriate decisions are made and related commands are sent back to controllable devices [2]. The information flow for centralized control strategy is illustrated in Fig. 1 [1]. Remote nodes denote data resources and controllable devices.

In decentralized control strategy, on the other hand, the entire system is divided into some multiple areas. Each area has its own control center which is known as an area control center (ACC) [2]. In each area, data resources transmit data to ACC of the area, and ACC processes the acquired data similar to that which CCC does. To control the entire system, ACCs share their

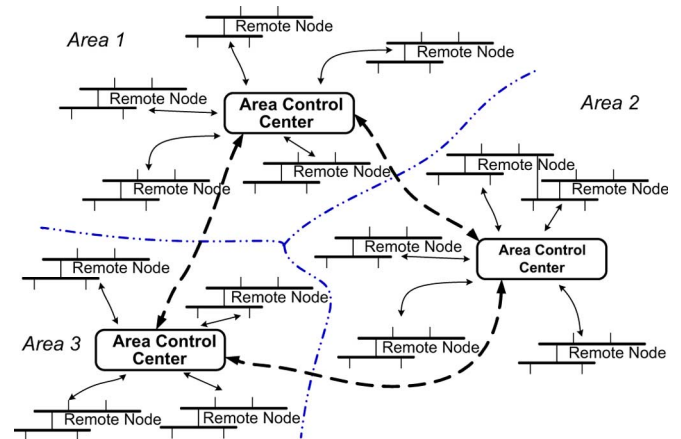

Fig. 2. Representation for a decentralized control strategy.

information among each other through communication systems. Fig. 2 shows a representation of information flow in three areas for a decentralized control strategy [1].

B. Functions of Control Centers

Control and optimization of power system functions are performed by using some type of software packages referred to as Energy Management System (EMS) [2]. Online state estimation (SE), load flow (LF), optimal power flow (OPF), load forecast (LF), and economical dispatch (ED) are some examples of EMS functions. Both types of control centers, CCC and ACC, execute EMS applications. The simulation time and computational load for these applications depend on power network size and its complexities.

Data provided by data resources are raw data. These raw data, which are transmitted to control center through communication system, cannot be used as input for EMS functions. State estimation is a kind of application extracts creditable data from raw data. These creditable data can be used by other EMS applications in control center. Therefore, SE may be referred the most important application in control center and should be considered as the basis of EMS applications [2]. State estimation, based on types of data resources, can be classified into conventional, PMU based, and hybrid SE. Traditional SEs, using conventional measurements (such as power flow-injections and voltage magnitudes), are known as conventional SEs. In cases in which SEs utilize phasor data, they are referred as PMU-based SEs. Hybrid SEs (HSEs) use data obtained from both conventional and phasor measurements.

C. Communication System

Power grid communication network is similar to humans' neural networks. As in case of failure or malfunctioning of neural network paralyzed may happen, failure of power grid communication network may cause huge problems in system operation and control. Consequently, especial attention should be paid to communication infrastructure, which is as important as electrical infrastructure itself. These two infrastructures (communication and electrical) have become increasingly interdependent so that in the case of failure for each of them, the other one may also become out of service [2], [4].

New communication systems are designed based on open system interconnection (OSI) layer model. In this architecture, upper layers relay data, assuming that the lower layers work perfectly [6]. In fact, this model is an effective architecture for explanation, design, implementation, standardization, and use of communications networks. The OSI reference model consists of seven layers: physical, data link, network, transport, session, presentation, and application [7].

The first layer of these systems, referred as the physical layer, is a kind of medium that establishes the physical connection between transmitter and receiver. The characteristics of the communication systems will become seriously influenced by the characteristics of its media. As a result, the characteristics of the transmission media play an important role in power grid communication infrastructure. Some main characteristics of a medium are as follows: cost, bandwidth, propagation delay, security, and reliability [7].

In our recent work [7], we have classified power grid transmission media into two main groups; dependent and independent ones. Dependent media are part of power network elements, i.e., power line communication (PLC), broadband over power line (BPL), optical power ground wire (OPGW), and all-dielectric self supporting (ADSS). In contrast, independent media do not depend on the power system and may be of the type available to all users as an open access media (for instance, wireless communication media) or those owned by data service providing companies (such as leased line or dedicated data links).

As dependent media is part of power systems and usually owned by an independent system operator (ISO), it can be co-optimally designed in conjunction with power system planning problems. In other words, dependent media provide the designer with the great opportunity of managing infrastructures interdependency problems.

III. PROBLEM DEFINITION AND FORMULATION

The aims of this study are twofold. Firstly, we have used an optimization method to design the minimum length communication backbone network for any given power grid with determined measurements. Secondly, we have proposed two new indices which can be used for comparing two different approaches of CIs. It should be mentioned that CI is established using a dependent transmission media (OPGW). The comparison criteria in our investigation are cost, latency, and reliability of communication networks.

To carry out this research, IEEE 118-bus test network has been used for our investigation. To consider two different control strategies (centralized and decentralized), this network has been considered in two different cases; considering the whole network as a single area network [8] and considering the network composed of nine interconnected subareas [9]. Then, the optimum CI (CI with the minimum length) has been designed for these two cases. The installed measurements for centralized and decentralized strategies are assumed to be such that the network becomes observable. Therefore, they are chosen to be the same as those in [8] and [9] for centralized and decentralized strategies, respectively. The control center (CC) may be geographically located anywhere in the system. In this research, we

have assumed that the centralized CC is not predetermined. Decentralized ACCs are assumed to be at the chosen slack buses of different areas.

As described before, power grid communication infrastructure planning can be applied as an optimization problem. HSE data resources, which are distributed at system buses, are taken as key nodes. The links between nodes are considered to be weighted. The length of each transmission line is considered as the weight for that link.

Since SE is a basis EMS application and provides credible information for other applications, the infrastructure which is connecting SE data resources to CC can be assumed as the communication backbone network (known as "high level networks"). Other networks; which are referred as "low level networks," can be connected to this backbone, if necessary. Breaking the entire network into high level and low level networks is a cost-effective structure for large communication networks [10].

The Minimum Spanning Tree (MST) problem is one of the well-known optimization issues used for designing backbone (high level) networks [10], [11]. MST tries to find a minimum tree network, which connects all the nodes as a communication network, and such that the sum of weighted lengths is minimized.

In our approach, the first step is to find MST as a communication backbone for both centralized and decentralized strategies. The next step is to compare major critical parameters of these two backbone networks including latency, reliability, and cost. To perform this comparison, two indices; NoR and LoM, have been defined and assigned to each node. NoR (number of routers) is a number of nodes between considered node and control center and also known as "network hops". LoM (length of media) represents the length of media between considered node and control center. The next two subsections explain the relation between these indices and two critical network parameters (latency and reliability).

A. Latency Calculation

The total signal latency may be represented as [12]

$$T = T_s + T_b + T_p + T_r \quad (1)$$

where T_s is the serial delay, T_b is the between packet delay, T_p is the propagation delay, and T_r is the routing delay.

Dividing the length of transmission media by the velocity of transmission media, propagation delay can be calculated as

$$T_p = \frac{\text{LoM}}{v} \quad (2)$$

where LoM is the length of the media and v is the velocity at which the data are sent through it (e.g., $0.6c$ to c , where c is the speed of light).

In [12], the path from a node to the CC is traced and all of the routing delays are added up. Hence, the total routing delay for a node can be represented as follows:

$$T_r = \sum_{i=1}^{\text{NoR}} T_{i^{\text{th}} \text{ Router}} \quad (3)$$

To simplify latency calculation, we assume that the T_s and T_b are constant. We also assume that all routers have the same latency value. Therefore, (1) can be developed as follows:

$$T = \text{Const} + \frac{\text{LoM}}{v} + \text{NoR} \times T_{\text{Router}}. \quad (4)$$

From (4), it can easily be concluded that latency will increase if LoM and NoR increase.

B. Reliability Calculation

Due to special characteristics of spanning tree network; calculation of its reliability is easier than those for other networks [13]. Due to the fact that only one path exists between any node and the control center; a node will be in service if and only if all links and nodes of this path work properly. As a result, we can assume that all components are series; therefore,

$$R_{\text{node}} = \prod_{i=1}^{\text{NoR}} R_{i^{\text{th}} \text{ Router}} \times \prod_{j=1}^{\text{NoL}} R_{j^{\text{th}} \text{ Link}} \quad (5)$$

where R_{node} is reliability of considered node; $R_{i^{\text{th}} \text{ Router}}$ is reliability of i^{th} node in the path between the node and the control center; $R_{j^{\text{th}} \text{ Link}}$ is reliability of j^{th} link in this path, and NoL is the number of links in the path.

For simplification of calculations, we assume that reliability values for all routers are the same. We also assume that the links between node and CC are jointed and its length is LoM. Thus, the (5) can be summarized as follows:

$$R_{\text{node}} = R_{\text{Router}}^{\text{NoR}} \times R_{\text{LoM}} \quad (6)$$

where R_{Router} is router reliability and R_{LoM} is reliability of jointed link.

For the purposes of illustration, we assume that the failure of an OPGW link only depends on its length [14]. Hence, the reliability of an OPGW link will reduce if its length increases. R_{Router} is less than one. Therefore, if R_{Router} is multiplied by itself NoR times, it will become smaller. Consequently, any increase in NoR or LoM values of a node results in decreasing the reliability of the node.

C. Cost Calculation

Communication network cost is mainly composed of the sum of two major costs including the cost of active devices and the cost of passive components. Equation (7) represents the total cost of communication network.

$$\text{Cost}_{\text{total}} = \text{Cost}_{\text{passive}} + \text{Cost}_{\text{active}} \quad (7)$$

where $\text{Cost}_{\text{passive}}$ is cost of passive components and $\text{Cost}_{\text{active}}$ is cost of active devices.

The cost of active devices mainly depends on the number of network switches and routers which are installed at backbone nodes. On the other hand, in fiber optic networks, price of passive components mainly depends on media length. As a result, $\text{Cost}_{\text{passive}}$ and $\text{Cost}_{\text{active}}$ correspond directly to the “total length of backbone network” and the “number of backbone nodes,” respectively.

IV. OPTIMIZATION APPROACH AND SIMULATION RESULTS

As explained before, a minimum spanning tree network must be designed such that all SE data resources can communicate with control center through this backbone network. This as an optimization problem should be solved using one of the optimization techniques. To perform this optimization, genetic algorithm (GA), which is one of the most useful offline searching methods, is chosen [10], [11]. IEEE 118-bus test network without any conventional communications has been used for our studies. To develop the optimization problem, two matrices including adjacency matrix (connection matrix) and distance matrix should be defined. The adjacency matrix is a matrix whose elements all are equal to zero or one. The element in the i^{th} row and the j^{th} column of the matrix is 1 if there is a direct connection between buses i and j and will be equal to zero if those buses are not directly connected to each other. The diagonal elements are equal to zero. The distance matrix is similar to adjacency matrix in which any of its elements represents the distance (length of transmission line connecting two buses) between two buses. Any element in the i^{th} row and the j^{th} column of the matrix equals zero if there is no transmission line between buses i and j . The diagonal elements, as the distance between any bus and itself, are equal to zero. To normalize LoM values, the largest element of distance matrix, representing the longest transmission line, is determined. Then, all other elements are divided by this maximal. As a result, the values of all elements of distance matrix are smaller or equal to one. Finally, using GA optimization technique, the communication infrastructures for two different cases, including; centralized and decentralized control strategies, have been designed.

A. Centralized Case

In this case, to design the communication infrastructure for the network, first, we find the minimum spanning tree for installed metering devices. In our study, the same as [8], metering devices include 114 power flow measurements, 39 power injection measurements, and 13 PMUs. Then, after finding backbone network, the location of control center should be selected. The method proposed by Cahit *et al.*, in [15], is adopted for finding CC. By using this method, buses 68 and 69 are candidate locations for control center. Therefore, the links and control center (assumed to be at bus 68) of backbone network are determined. Then, NoR and LoM indices can easily be calculated for each CI node. The Breadth-First-Search (BFS) algorithm is used for estimating NoR and LoM [16]. BFS traverse a graph by visiting all the nodes connected directly to a starting node (control center node in this case). These indices will be used to compare the reliability and latency of centralized control strategy with decentralized one.

B. Decentralized Case

In this case, we assume that the location of control center in each area is *a priori* determined (assumed to be at the slack bus of the area which is a PMU enabled bus). The entire system is divided into 9 areas. The system is assumed to have a total of 9 voltage magnitude measurements, 187 pairs of power flows, 59 pairs of power injections, and 9 synchronized phasor measurements (which are installed in ACC) [9].

TABLE I
CENTRALIZED AND DECENTRALIZED INFRASTRUCTURE COMPARISON

| Strategy | Area No. | No. of Buses | No. of Measurement | Loc. of C.C. | No. of MST Nodes | No. of MST Links | Coverage (Percent) |
|---------------|-------------|--------------|--------------------|--------------|------------------|------------------|--------------------|
| Centralized | Entire Net. | 118 | 98 | 68 | 110 | 109 | 47.01 |
| Decentralized | Area 1 | 13 | 11 | 3 | 11 | 10 | 2.14 |
| | Area 2 | 13 | 13 | 18 | 13 | 12 | 6.85 |
| | Area 3 | 12 | 10 | 35 | 11 | 10 | 5.31 |
| | Area 4 | 14 | 11 | 27 | 13 | 12 | 5.48 |
| | Area 5 | 13 | 11 | 76 | 12 | 11 | 4.55 |
| | Area 6 | 13 | 12 | 47 | 12 | 11 | 4.59 |
| | Area 7 | 13 | 9 | 103 | 9 | 8 | 3.56 |
| | Area 8 | 14 | 13 | 93 | 14 | 13 | 6.28 |
| | Area 9 | 13 | 11 | 55 | 13 | 12 | 4.44 |
| | Inter-area | 9 | — | 47 | 9 | 8 | 1.93 |
| Total | Entire Net. | 118 | 105 | 47 | 108 | 107 | 45.13 |

First, GA optimization algorithm has been used for finding MST in each area. Due to reduction of sizes of areas, the sum of computation time for finding 9 MSTs, of these 9 areas, is smaller than that for centralized case. BFS has been used to estimate NoR and LoM values. The next step is finding interarea connections. To carry out this step, we assume that each area is a single node and these nodes are connected to one another through boundary buses; which belong to backbone networks of the areas. The links between two areas may be more than one; hence, none bit genes should be used for representing area connections. Then, to collect data of areas and to estimate states of the entire system, a CCC is selected for the entire network. This is done using the method represented in [15]. The ACC in any area may be selected as the CCC. Using the algorithm for finding CCC, ACC of area 3 and 6 will be best candidates for CCC. Finally, having nine MSTs of the 9 areas (obtained in the first step) together with interarea connections (obtained in the second step), the infrastructure plan for the entire system can be concluded.

C. Simulation Results

Table I shows the results of communication infrastructure planning derived from optimization.

The columns “No. of Buses,” “No. of Measurement,” and “Loc. of C.C.” represent number of bus in the area, number of measurements installed in the area and the location of control center in the discussed area, respectively. Three next columns denote area backbone network characteristics. To connect all measurements to backbone network, OPGW media will cover some intermediate nodes without any measurement. Therefore, the total number of nodes in MST will be different from the total number of measurements in the network. As a result, the number of routers in the backbone (also known as active devices) will be more than the number of measurement devices. The last column in Table I illustrates the coverage percentage of transmission media (relative media length to total length of transmission lines), also known as passive parts of communication system.

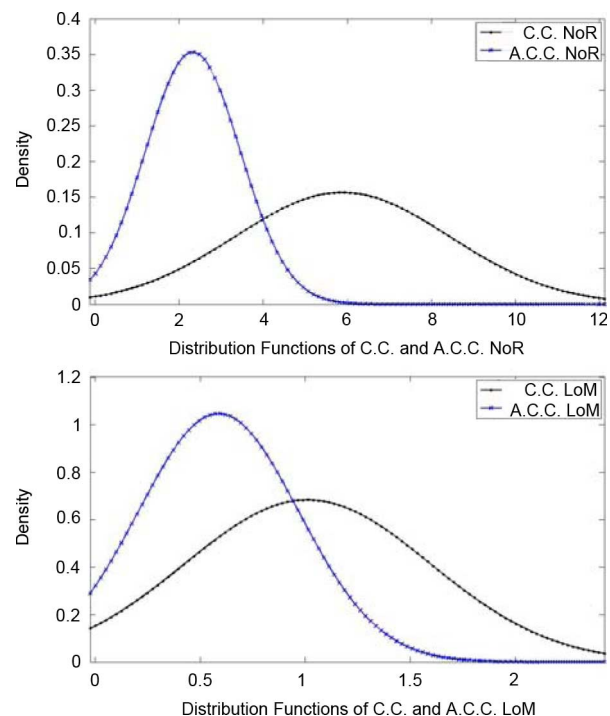

Fig. 3. Distribution function of NoR and LoM.

TABLE II
VARIANCE AND MEAN VALUES OF NoR AND LoM

| Strategy | Value | Mean | Variance |
|---------------|-------|----------|----------|
| Centralized | NoR | 5.88073 | 6.4949 |
| | LoM | 1.01081 | 0.340116 |
| Decentralized | NoR | 2.3211 | 1.27557 |
| | LoM | 0.586628 | 0.145168 |

D. Cost Comparison

A careful study of “Entire Net.” rows in Table I illustrates that the number of MST nodes and length of MST (Coverage column) in centralized and decentralized cases are almost equal. According to (7), this means that the costs of centralized and decentralized communication network are almost equal.

E. Latency and Reliability Comparison

As explained before, NoR and LoM indices can be used as useful measures for comparing the latency and reliability of different communication infrastructures. To perform an analytic comparison between CIs of centralized and decentralized control strategies, normal distribution functions of these two indices are obtained based on their distribution histograms (Fig. 3). Then, using these functions, variances and mean values of these indices are calculated. Table II shows variances and mean values of NoR and LoM.

As it can be observed from data illustrated in Table II, the average of communication network hops for centralized control strategy is three times bigger than that of decentralized one. This is concluded from the fact that the mean value of NoR in communication network of centralized control strategy is three times bigger than that in decentralized one. It can also be observed that the length of transmission media for centralized communication network, which connects a node to CC, is almost equal with the length of longest transmission line. On the other hand,

for decentralized communication network, the length of transmission media is almost equal to sixty percent of its length for centralized case. Consequently, communication network in case of decentralized control strategy, as compared with communication network in case of centralized control strategy, can be considered a suitable method for improving network latency and reliability.

From Table II, it can also be seen that variances of NoR and LoM in centralized network are larger than those in decentralized one. Therefore, it can be easily concluded that latency variations in communication network for central control strategy is higher than that of decentralized one. This may similarly be concluded for reliabilities variations.

V. CONCLUSION

To control new competitive power industries securely, new control strategies should be used by system operators. Control strategy can be recognized by information flow among different entities in the system. In power systems, the communication infrastructure is responsible for information exchanging. Therefore, especial attention should be paid to the design of communication infrastructure.

Our study confirms that while the investment for communication infrastructure of power systems in centralized and decentralized control strategies are almost the same, communication latency in centralized case is higher than that in decentralized one. Furthermore, the reliability of communication network is improved by decentralizing infrastructure.

Simulation results confirm that, on the average, the number of “networks hops” in centralized infrastructure is three times bigger than that in decentralized one. Alternatively, the path between a node and control center in decentralized infrastructure is 60% of centralized one.

It is shown that, while the cost of communication network for decentralized control strategy is almost equal to the cost of communication network for centralized control strategy, the communication latency and reliability have been greatly improved in decentralized case.

REFERENCES

- [1] O. Gehrke, S. Ropenus, and P. Venne, “Distributed energy resources and control: A power system point of view,” in *Proc. Risø Energy Conf.*, Roskilde, Denmark, 2007, pp. 248–257.
- [2] M. Shahidehpour and Y. Wang, *Communication and Control in Electric Power Systems*. Hoboken, NJ: Wiley-IEEE Press, 2003.
- [3] J. D. McDonald, *Electric Power Substations Engineering*, 2nd ed. Boca Raton, FL: CRC, 2007.
- [4] Z. Lukszo, G. Deconinck, and M. P. C. Weijnen, *Securing Electricity Supply in the Cyber Age: Exploring the Risks of Information and Communication Technology in Tomorrow's Electricity Infrastructure*. New York: Springer, 2010.
- [5] H. Bevrani, *Robust Power System Frequency Control*. New York: Springer, 2009.
- [6] F. Wu, K. Moslehi, and A. Bose, “Power system control centers: Past, present, and future,” *Proc. IEEE*, vol. 93, no. 11, pp. 1890–1908, Nov. 2005.

- [7] M. Shahraini, M. H. Javidi, and M. S. Ghazizadeh, “A new approach for classification of data transmission media in power systems,” in *2010 Int. Conf. Power Syst. Technol. (PowerCon 2010)*, Hangzhou, China, Oct. 24–28, 2010.
- [8] J. Chen and A. Abur, “Placement of PMUs to enable bad data detection in state estimation,” *IEEE Trans. Power Syst.*, vol. 21, pp. 1608–1615, Nov. 2006.
- [9] L. Zhao and A. Abur, “Multiarea state estimation using synchronized phasor measurements,” *IEEE Trans. Power Syst.*, vol. 20, pp. 611–617, May 2005.
- [10] L. Lin and M. Gen, “Node-based genetic algorithm for communication spanning tree problem,” *IEICE Trans. Commun.*, vol. E89-B, no. 4, pp. 1091–1098, Apr. 2006.
- [11] J. R. Kim, J. U. Lee, and J.-B. Jo, “Hierarchical Spanning Tree Network Design with Nash Genetic Algorithm,” *Comput. Ind. Eng.*, vol. 56, no. 3, pp. 1040–1052, Apr. 2009.
- [12] J. W. Stahlhut, T. J. Browne, G. T. Heydt, and V. Vittal, “Latency viewed as a stochastic process and its impact on wide area power system control signals,” *IEEE Trans. Power Syst.*, vol. 23, pp. 84–91, Feb. 2008.
- [13] M. L. Shooman, *Reliability of Computer Systems and Networks: Fault Tolerance, Analysis, and Design*. Hoboken, NJ: Wiley, 2002.
- [14] J. Zhang, K. Zhu, H. Zang, and B. Mukherjee, “A new provisioning framework to provide availability-guaranteed service in WDM mesh networks,” in *Proc. IEEE Int Conf Commun*, May 2003, pp. 1484–1488.
- [15] I. Cahit and R. Cahit, “Structural reliability of centralised tree network,” *IET Electron. Lett.*, vol. 9, no. 26, pp. 621–622, Dec. 1973.
- [16] T. H. Cormen, C. E. Leiserson, R. L. Rivest, and C. Stein, *Introduction to Algorithms*, 2nd ed. Cambridge, MA: MIT Press, 2001.



Mohammad Shahraini (S'07) received the B.S. and M.S. degrees from the Department of Electrical Engineering, Ferdowsi University of Mashhad, Mashhad, Iran. He is currently working toward the Ph.D. degree in the Department of Electrical Engineering, Ferdowsi University of Mashhad.

His interests include computer application of smart grids, wide area measurement systems, communication infrastructure in power systems, and distribution automation.



Mohammad Hossein Javidi received the B.Sc. degree from Tehran University, Tehran, Iran, in 1980, the M.Sc. degree from Nagoya University, Nagoya, Japan, in 1985 and the Ph.D. degree from McGill University, Montreal, QC, Canada, in 1994, all in electrical engineering.

He was a Board Member as well as the Secretary of the electricity regulatory body in Iran for seven years (2003–2010). He is currently a Professor in the Department of Electrical Engineering, Ferdowsi University of Mashhad, Mashhad, Iran. His research interests include power system operation and planning, restructuring and market design, and artificial intelligence.



Mohammad Sadegh Ghazizadeh received the B.Sc. degree from Sharif University of Technology, Tehran, Iran, in 1982, the M.Sc. degree from AmirK-abir University of Technology, Tehran, in 1988, and the Ph.D. degree from University of Manchester (UMIST), Manchester, U.K., in 1997, all in electrical engineering.

He is currently Assistant Professor in the Department of Electrical Engineering of Power and Water University of Technology, Tehran. He is advisor to the ministry of energy and head of the electricity regulatory board in Iran. His research interests include power system dynamics and control, restructuring and electricity market design, and energy economics.