

# Internet of Things in agriculture: A survey

Mahmoud Abbasi  
Department of Computer  
Engineering, Azad University of  
Mashhad, Mashhad, Iran  
Mahmoud\_abbasi\_student@yahoo.com

Mohammad Hossein Yaghmaee  
Department of Computer  
Engineering, Ferdowsi University  
of Mashhad, Mashhad, Iran  
hyaghmaee@um.ac.ir

Fereshteh Rahnama  
Department of Computer  
Engineering, Azad University of  
Mashhad, Mashhad, Iran  
fereshte.rahnama68@gmail.com

**Abstract**—Increasing food consumption, asking for quality food, and environmental impacts of agriculture lead to has used information technology in the agriculture sector, which comes under the heading of precision agriculture. Internet of things (IOT) is a tech-nology that is growing rapidly in recent years and brings numerous benefits with it for agriculture. Because of the heterogeneous and enormous amount of data collected by IoT devices, future of internet of things (IoT) agricultural applications depend on cloud computing. At the same time, microcontrollers will add new abilities to the internet of things (IoT). In this survey, the research trend, the concepts, fundamental components of IOT, the challenges, and IOT applications in agriculture are examined. Firstly, the numbers of published papers in this field reviewed. Secondly, IOT definition and IOT architecture together with its layers are introduced. Thirdly, some involved technologies in the IOT are compared; finally, the main challenges in IOT and precision agriculture (PA) are considered.

**Keywords:** *Internet of Things; Precision agriculture; Machine to Machine;*

## I. INTRODUCTION

Internet of things, IOT, is a novel application domain that integrates different technologies (software) and devices (hardware) such as wireless telecommunications technology, sensors, Radio-Frequency Identification (RFID) tags, actuators, mobile phones, etc. Kevin Ashton invented the word ‘Internet of Things’ in 1999. The first interesting characteristic of IOT originated from the name that describes it. It is a set of physical interconnected objects or “Things”. Physical entities can be an animal, humans, cars, environments, appliance etc. Furthermore, the “Internet” refers to the fact that “Things” are connected to the internet. Additionally, each “Thing” has an identifier in order to be identifiable.

Generally, characteristics and abilities of the IOT make possible to use this technology in many application domains while because of existing limitations and challenges[1] only small numbers are now applicable to our community. Agriculture is one of the domains that have been affected by IOT and lead to a coined new area that named Precision Agriculture. According to [2], precision agriculture is an approach to use information technology (IT) to improve the quality of crops and increase yields. Overall, the goal of precision agriculture is to improve farmers’ profits and harvest yields while declining the negative effects of farming on the environment that result from overuse of fertilizers. By 2050 the world’s population will reach 9.6 billion, 36 percent higher

than today, Food consumption in the next 30 years may rise to 3070 kcal/person/day by 2050[3]. At the same time, annual production of main crops will need to grow from the current amount to almost one billion further. This quick population growth and the related issues will cause additional worry on food production.

Modern agriculture especially precision agriculture (PA) has a key role in helping to enhance crop yields[4]. PA promises to make agriculture extremely effectiveness to make sure high productivity levels and reduce the environmental impact of farming. Additionally, PA positive approaches have a marked effect on greenhouse gas emissions. Precision agriculture thanks to advanced technologies such as WSN, sensors, RFID, actuators, etc. is able to cut the amount of fertilizers and pesticides, as it optimizes the needs of the fields and indoor agriculture. In recent years, there have been advances in low-cost and low-power sensors. These sensors measure soil moisture, temperature, humidity and other parameters such as water content, outdoor temperature, wind speed etc. Data collected from the sensors analyze by data analysis methods which helping to extract more information from the data, decision making support systems and create more accurate prediction models. Moreover, PA also considered as an approach based on data[5]. Researchers use data mining methods (classification, clustering, regression, etc.) in order to deal with a complex issue, yield prediction.

Uses of IoT technologies in different fields have a significant growth, some of which are: healthcare, smart cities, industries, agriculture, traffic management, military, smart grid and others[6], so we carry out a wide-ranging review of related work in three renowned scientific databases (IEE, Springer, and ScienceDirect) to investigate the recent trend in IOT related publication. Fig. 1 describes the number of publications indexed in the three major scientific databases over an eight years period between 2010 and 2017. Meanwhile, in recent years there has been a sharp rise in the trend of submitted research articles related to applications of the internet of things in agriculture in the scientific databases (see Fig. 2). In this paper, we use the Google Scholar search engine for compare the number of publications between 2010 and 2017. The results obtain by browsing the keywords ‘IOT and agriculture’, ‘IOT and precision agriculture’, ‘IOT and farming’, ‘IOT and smart agriculture’. This dramatic increase drives us to study to investigate the latest scientific research on applications of IoT in agriculture.

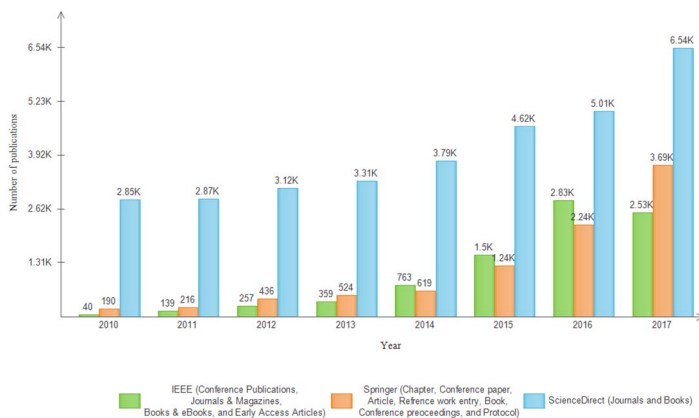

Figure 1. Number of IOT related publications by year

## II. BACKGROUND AND CONCEPT OF IOT

Generally, the “Internet of Things” or “Internet of Object” refers to a set of networked thing, each equipped with sensors which they are connected to the internet[7]. IEEE P2413 deploys three-layer architecture for IoT which the layers named the Application, Networking and Commutation, and Sensing layers, respectively. In Fig. 3 the roles of each layer explain in brief.

Radio-Frequency Identification (RFID) plays a vital role in the history of IOT. RFID technology uses radiofrequency waves in order to send gathered data from a mobile physical entity to RFID reader. Other key technologies associated with IOT are including identification technology, sensing technology, and communication technology [4,5]. From recognition and addressing point of view, identification technology is vital for the IOT. Electronic produce codes (EPC) and ubiquitous code (uCode) are two major identification techniques for the IOT[6]. In addition, addressing IOT devices which connect to the internet lead to another problem. To solve the problem, addressing methods such as IPv6 and 6loWPAN-IPv4 are used[8].

The IOT sensing technology is a network established by a number of sensors to sense analog data such as light, pressure, temperature, wind speed, and etc. Collected data might involve in aggregation and preprocess techniques in order to reduce the data traffic and increase the sensor node lifetime. Various forms of communication technologies have been used by IOT such as WiFi, ZigBee, Bluetooth, IEEE 802.15.4, LTE, and 5G. The IOT requires a standard way to connects IOT devices to each other and to the internet. The European Telecommunications Standards Institute (ETSI) refers to the machine to machine (M2M) communication instead of the word IOT. WiFi or wireless local area network (WLAN) plays a vital role in M2M communication. IOT communication needs two necessary characteristic, ubiquity and reliability. The WiFi or IEEE 802.11 standard is one of the promising technologies for IoT communication. Today, there are a growing number of WiFi connections in everywhere which things can be connected to the internet through it. Moreover, IEEE 802.11ah

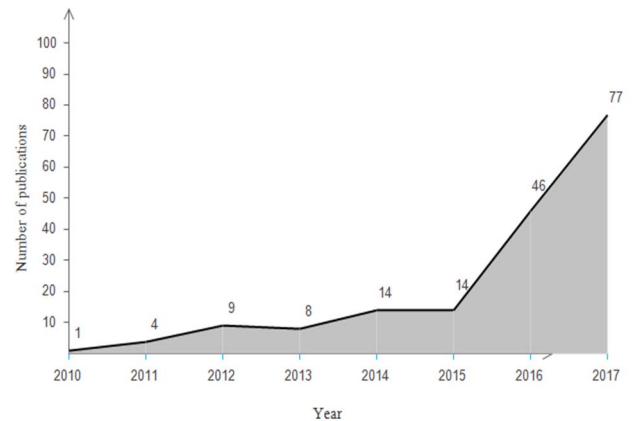

Figure 2. Trend of publications in the field of IOT in agriculture (or WiFi-HaLow) which is a novel version of WiFi technology provides communication between more than 8000 devices

Figure 2. Trend of publications in the field of IOT in agriculture

involve in typical IOT applications such as smart grid, smart healthcare, smart agriculture, supply chain management etc.[9]. Note, another foundational technologies and elements for IoT are a barcode, Near Field Communication (NFC), Artificial Intelligence (AI), computational technology, and others.

## III. IOT AND ENABLING TECHNOLOGIES

### A. IOT hardware platforms

Internet of things is developing in recent years rapidly thanks to the small, low price microcontroller and computing hardware. Table 1 shows the popular hardware platform used in the precision agriculture researches and projects that categorized according to main their parameters. This hardware equipped with processors, wireless chips, memory and other components.

### B. The IoT cloud platforms in the context of agriculture

An IOT cloud platform is a key component for IOT solutions in all application domains. A number of the popular cloud computing companies such as Microsoft, Google, Amazon, and others introduced the own IOT as a service. The IOT cloud platform has the benefit of scalability, virtualization, low price, and large scale. The precision agriculture use sensors, RFID, wireless communication, intelligent systems and other ICT technologies in order to implement the monitoring and controlling systems. In the systems, farmers, experts or even scientists use the collected data for different purposes (analysis, visualization, computing, forecast future events, future works etc.).So, the IOT cloud platform is a potential candidate to satisfying these purpose in the secure and efficient way. Moreover, the IoT devices can relay the data to the other the IoT devices via the internet. The IOT platform is able to cover the difference between the data network and device sensors. Table 2 shows a comparative perspective between the famous IOT cloud providers that they are used in the precision agriculture.

TABLE I. TYPE IOT AGRICULTURE HARDWARE PLATFORMS

Source of literature	[10-16]	[17-19]	[20-24]	[25-28]	29-33]	[34-37]
Parameters	Arduino Mega	Arduino Uno	Arduino Yun	Beaglebone Black	Raspberry Pi3 (B model)	Intel Galileo
Microcontroller	ATmega1280	ATmega328	ATmega32u4/Atheros (Linux microprocessor)	Sitara AM3359AZCZ10 0 1GHz, 2000 MIPS	Broadcom BCM2387 chipset	Intel Quark SoC X1000
Operating Voltage	5V	5V	5V/3.3V	3.3 V	5V	5V
Clock Speed (MHz)	16	16	16,400	1GHz	1.2 GHz	400MGz
Bus With	8 bits	8 bits	8 bits	32 bits	32 bits	32bits
Flash Memory	128 KB	32 KB	32 KB, 16MB	2GB	-	8MB
Memory	8 KB	2 KB	2.5 KB, 64MB	512 MB	1GB	256MB
EEPROM (KB)	4	1	1	-	-	11KB
Wireless and wired Communication	802.11 b/g/n (WiFi shield), 802.15.4 (Wireless SD Shield and Series XBee modules), RF 315/433 MHz, Bluetooth (HC-05 module)	802.11 b/g/n (WiFi shield), 802.15.4 (Wireless SD Shield and Series XBee modules), RF 315/433 MHz, Bluetooth (HC-05 module)	802.11 b/g/n , 802.15.4 (Wireless SD Shield and Series XBee modules), RF 315/433 MHz, Bluetooth (HC-05 module), USB, Ethernet	IEEE 802.11 b/g/n, Bluetooth, IEEE 802.15.4, USB 2.0, Ethernet 10/100, HDMI	IEEE 802.11 b/g/n, Bluetooth 4.1 (Bluetooth Classic and LE), USB, HDMI, Ethernet 10/100	IEEE 802.11 b/g/n (external modules), Bluetooth LE, IEEE 802.15.4, USB, HDMI, Ethernet 10/100,
IDE	Arduino IDE, Arduino Web Editor, Makefiles, AVR Studio	Arduino IDE, Arduino Web Editor, Makefiles, AVR Studio	Arduino IDE, Arduino Web Editor, Makefiles, AVR Studio	Cloud9 IDE, AdaFruit WebIDE, Eclipse, Netbeans, Arduino IDE	Bluej, Adafruit WebIDE, Geany, AlgoIDE, Ninja IDE	Arduino IDE, Arduino Web Editor, Intel XDK, Intel System Studio IoT Edition
Programming	Arduino language	Arduino language	Arduino language	C, C++, Python, Perl, Ruby, Java, or even a shell script	C, C++, Java, Python, Ruby	C, C++, Java, Javascript, Node.js Arduino language
Input/Output	PWM, SPI, I2C		TWI, PWM, SPI, I2C	GPIO, PWM, I2C, SPI, UART	GPIO, I2C, SPI, UART, SD/SDIO, DPI	UART, GPIO, SPI, I2C
Physical Characteristics	4*2.1 Inches	2.7*2.1 Inches	2.7*2.1 Inches	86.36*53.34mm	85*56 mm	4.2*2.8 Inches

1

TABLE II. IOT CLOUD PLATFORMS

Parameters	Data Visualization	Data Analytics	Scalability	Security Model	Real time data	Support Over millions of devices	Pricing	Other Features
AWS IoT Platform	Yes (Amazon QuickSight)	Yes (Amazon Kinesis Analytics)	Yes	X.509 certificate	Yes	Yes	<ul style="list-style-type: none"> <li>\$0.20 per GB of data processed.</li> <li>\$0.03 per GB of processed data stored per month.</li> <li>\$6.50 per TB of data scanned.</li> </ul>	<ul style="list-style-type: none"> <li>Provides Hardware resources.</li> <li>On demand services like other platforms.</li> <li>Device shadows</li> <li>Rules engine</li> </ul>
Microsoft Azure IoT Hub	Yes (the Web Apps)	Yes	Yes	Permissions (security tokens)	Yes	Yes	<ul style="list-style-type: none"> <li>Free (8,000 messages/day per unit).</li> <li>S1: \$50 per month (400,000 messages).</li> <li>S2: \$500 per month (6 million</li> </ul>	<ul style="list-style-type: none"> <li>Agility</li> <li>Easy way for business transformation</li> <li>IoT protocols and extensibility</li> </ul>

Third International Conference on Internet of Things and Applications, University of Isfahan, Isfahan, Iran

							messages). S3: \$5,000 per month (300 million messages).	Extensive set of device libraries
IBM Watson IoT Platform	Yes	Yes	Yes(with IOT on Bluemix)	<ul style="list-style-type: none"> <li>Secure by design</li> <li>Security controls</li> </ul>	Yes	Yes	<ul style="list-style-type: none"> <li>Lite plan: first 30 days of trial is free ( after the trial \$0.00 USD per month)</li> <li>Standard plan: Pay for what you use by tier.</li> <li>Advanced Security plan : Pay for what you use by tier.</li> </ul>	<ul style="list-style-type: none"> <li>Secure connectivity and architecture.</li> <li>Data management.</li> <li>Device last event cache.</li> <li>Gateway devices</li> </ul>
Google Cloud Platform	Yes (Google Cloud Datalab )	Yes	Yes	<ul style="list-style-type: none"> <li>security model is an end-to-end process</li> <li>several layers of encryption</li> </ul>	Yes	Yes	<ul style="list-style-type: none"> <li>Up to 250MB : \$0.00 per MB/ Unlimited devices</li> <li>250MB to 250GB: \$0.0045/ Unlimited devices</li> <li>250GB to 5TB: \$0.0020/ Unlimited devices</li> <li>5TB to above: \$0.00045/ Unlimited devices</li> </ul>	<ul style="list-style-type: none"> <li>Real Time Stream Processing</li> <li>Real Time Stream Processing</li> <li>Google's BigData tool</li> <li>Pay as you use strategy</li> <li>Connecting Arduino and Firebase and Cassandra on Google Cloud Platform</li> </ul>
Oracle IoT Platform	Yes	Yes	Yes	<ul style="list-style-type: none"> <li>CASB</li> <li>Security Monitoring and Analytics</li> <li>Cloud native</li> </ul>	Yes	Yes	<ul style="list-style-type: none"> <li>Oracle Internet of Things Cloud – Enterprise: \$3.377 (OCPU per hour).</li> <li>Oracle Internet of Things Cloud - Enterprise - Non-metered: \$2,500.00</li> </ul>	<ul style="list-style-type: none"> <li>High Speed Messaging</li> <li>Endpoint Management</li> <li>Stream Processing</li> <li>Data Enrichment</li> <li>Event Store</li> </ul>
Salesforce IoT	Yes	Yes	Yes(Salesforce Thunder)	<ul style="list-style-type: none"> <li>Secure Identity and Access Management</li> <li>point-and-click security tools</li> <li>Session-Based Permission Sets and Security</li> <li>Salesforce Mobile App Security and Compliance</li> </ul>	Yes	Yes	<ul style="list-style-type: none"> <li>Pay per use and service</li> </ul>	<ul style="list-style-type: none"> <li>real-time decision making and high speed</li> </ul>
SAP IoT Platform	Yes	Yes	Yes	<ul style="list-style-type: none"> <li>Authentication, single sign-on, on-premises integration and self-services such as registration and password reset</li> </ul>	Yes	Yes	<ul style="list-style-type: none"> <li>Pay per use and service (variety of packages)</li> </ul>	<ul style="list-style-type: none"> <li>Process Data Streams in Real Time</li> <li>Remote Data Sync</li> <li>IoT Application Enablement</li> <li>SAP Edge Services</li> </ul>

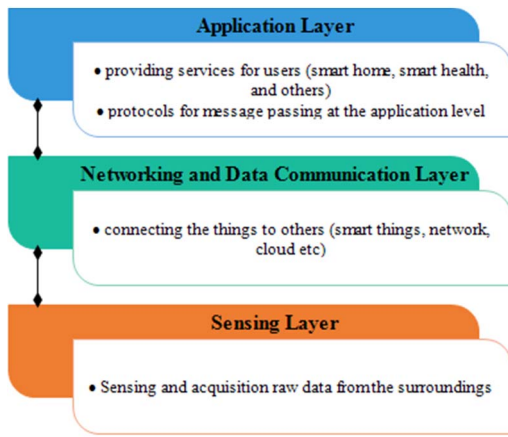

Figure 3. Three-layer IOT architecture

### C. Machine To Machine (M2M) communications in agriculture

According to the [7], Machine to Machine (M2M) communications refers to a channel of communication between two or more things that are created almost without direct human intervention. M2M services are looking for automation in the decision and communication processes. M2M technology is able to connect agricultural machinery, cars, devices to the other things wirelessly by using a wide range of communication technologies such as Internet Protocol (IP), WiFi, and SMS, in order to reduce direct human intervention beside provision of service. M2M plays a vital role in the OT; in fact, this technology is a very important and necessary part of the IOT, which enable agricultural machinery, cars, devices and in general other things that connected to the internet activity in a coordinated manner.

There are different wired and wireless types of M2M connectivity technologies (see Table 2). The Wireless technology especially WiFi, Zigbee, Bluetooth, and Wide Area Networks (WAN) are being used widely in agriculture IOT solutions [38]. In this case, we interest in the WAN (cellular M2M). Cellular M2M communication is a fresh type of wireless communication [39]. In the field of M2M, cellular communications can use to send data of machines to the base station. Additionally, wired networks have some weakness in the infrastructure, cost, maintenance, mobility, and others. So, cellular M2M is a possible candidate technology in agriculture. Agricultural parameters for example temperature, humidity, wind speed, location and other parameters can be sent and received via M2M communication. Cellular M2M architecture and partners describe in Fig. 4. The partners in the device domain e.g. machine, animals can be monitored remotely for their status of the operation, health condition, diagnostics etc. This can significantly reduce time, cost and endeavor. Also, it is possible to equip the devices with a wireless modem, which used for communication with the M2M service core. End users can get alerts on their mobile or tablet by SMS/Email. Control rules for any device and operation can be set by User Interface (UI). For example, 'turn on smart irrigation system when soil moisture is 20%'. It should be noted that a farmer need to has

an overall insight into the farm and this item realizes by data visualization and analytics in a cloud server.

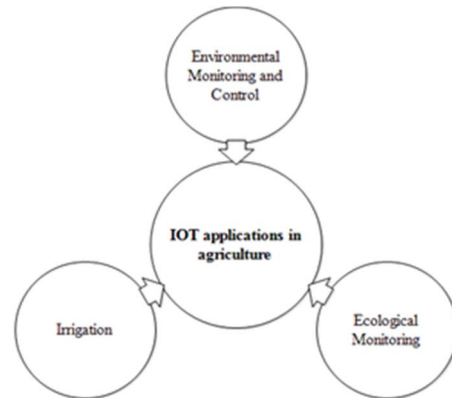

Figure 4. The applications of IOT in agriculture

### D. Agriculture smartphone Apps

Information and communication technologies have spread around the world and in almost everywhere there are signs of technology. ICT has played an important role in precision agriculture (PA) and has facilitated agricultural tasks especially with the help of telecommunication and smartphone [40].

Today due to the advances in smartphones processor and operating systems, these devices are increasingly being used in the many sectors (e.g. healthcare, industries, smart grid, and agriculture). Almost all new smartphones can perform most of the tasks of a computer. Moreover, according to the increasing rate of use of smartphones, a large number of Apps has been developed for a large number of operations. Almost there is an App for each profession and sector in order to help and facilitate the tasks. Likewise, for agriculture, many Apps are developed that can help to the farmers in different methods. We have done research on Apps in the context of agriculture that they provide a different range of services in agriculture. Table 4 presents a summary description of these Apps.

## IV. INTERNET OF THINGS APPLICATIONS IN AGRICULTURE

Precision Agriculture (PA) is a modern management approach benefit from information technology, geographic information system (GIS), GPS, WSN, data collecting etc. These technologies try to increase crop yields and reduce the environmental impact. That way, the internet of things with help of its enabling technologies is a candidate for using in the PA. The technological advance in low-power and low-cost sensors enables the WSN to collect a body of environmental data and send through wireless media to a database. The gathered data may undergo an abstract analysis for essential feedback or directly send to the database for an in-depth analysis [41]. In addition, modern agriculture is looking to change traditional agriculture into high-quality, high-yield, water saving, and smart agriculture. According to the previous discussions, the IOT technology is a promising and possible approach to realize these goals. The most important applications of IoT in agriculture are drawn in Fig. 5.



A. environmental monitoring and control

The wireless sensor network is a key technology in the current century. They have some characteristics such as scalability, homogeneity, and heterogeneity of nodes, fault tolerance, energy efficiency, and communication capabilities that make them suitable for monitoring agriculture and greenhouse environment. WSN made up of a number of nodes with sensing, communication, and computational abilities. WSN’s sensor nodes can measure and process several environmental parameters e.g. soil moisture, temperature, humidity, water pH, wind speed etc.[42]. At the same times, because of the unpredictable weather, lack of water, environmental effects, and plant diseases cultivate crops and plants is a difficult task. So in order to address these problems we have to use modern agriculture monitoring systems. According to the WSN’s characteristics, this technology is expected to offer effective monitoring systems to overcome the problems[38].

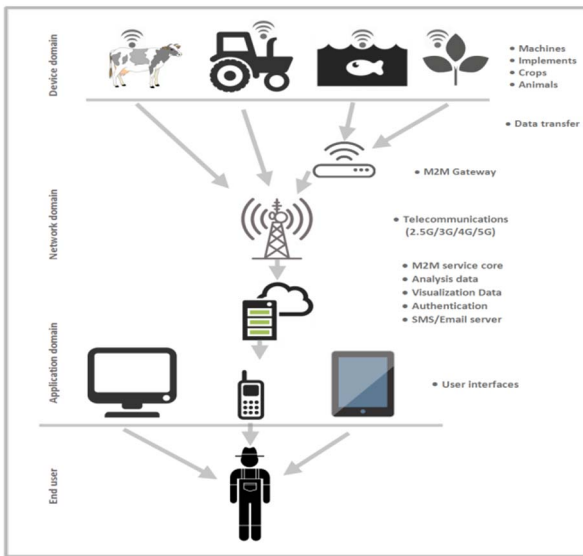

Figure 5. Cellular M2M general architecture

TABLE III. EXAMPLES OF M2M CONNECTIVITY TECHNOLOGIES

	Wide Area Network	Local Area Network	Personal Area Network
<b>Wireless</b>	2.5G, 3G, 4G, 5G, satellite	WiFi, Z-wave, Zigbee, Insteon, IrDa, DSRC	Bluetooth, ANT+, NFC, RFID
<b>Wired</b>	Fiber, Cable, DSL, PLCC, Broadband over power line (BPL)	G.Hn, KNX, HPNA, MoCA, UPA, Ethernet, CAN bus	-

Greenhouse monitoring and control system has been developing very rapidly. The most effective parameters for greenhouse plants that should be controlled to ensure optimal growth and productivity are included light, the level of carbon dioxide (CO<sub>2</sub>), temperature, and humidity. In this way, the sensors have measured the parameters, and an expert on greenhouse who equipped with smartphone, tablet or PC was used to analyze the gathered data and automated control some

parameters[43]. Monitoring of these parameters provides useful information for farmers and experts about plants’ grow and how each parameter produce an effect on plants productivity. Fig.6 shows an overview of the IOT technologies (sensors, wireless communication etc.) organization in a field and a greenhouse environment. Several sensor nodes are deployed all over the field and the greenhouse in order to gather, preprocess and send measured data. Furthermore, the gateway connects the sensor nodes to the servers cloud. Drones and camera nodes in the field can capture images. These images use for more analysis (reduce crop damage and vegetation index)[44]. The data is sent to the servers cloud for storing, analysis, visualization. The user can interact with the monitoring system via tablet, PC, laptop, and smartphone.

B. Ecological monitoring

The influences of human activities and natural factors have been caused by environmental pollution, climate change, and change into biological communities and species[45]. Ecological monitoring is a complex and continuing task because change process in the natural environment is complex and the implementation of an ecological monitoring system is a slow procedure. So, we need a long-term ecological monitoring system to disclose these changes. Ecological monitoring is a systematic approach for collecting ecological data over a long duration. Also, there are different types of monitoring such as result monitoring, outcome monitoring and surveillance monitoring[46]. Therefore, we are needed ubiquitous, constant, and real-time monitoring systems in order to satisfy these desires. The emergence of Information Technology (IT) leads to reacting to ecological changes in a new way. Environmental internet of things (EIoT)[47] technologies may be one of the possible candidates that can sense, collect, preprocess, and send a variety of environmental data and monitor ecological parameters in a good manner. The ecological monitoring systems have benefited from the growth of the EIoT by simulation the environment and monitoring systems. The using of the EIoT can assist us to provide effective technological solutions for the ecological problems.

Environmental wireless sensor networks include a set of distributed sensors that offer remote ecological data, real-time data visualization, and analysis, and merge with neighboring networks. The WSNs have several characteristics (e.g., continuous monitoring, on-demand, event-based) [48]. These characteristics help to monitor multiple ecological parameters such as temperature, atmospheric carbon dioxide, soil carbon dioxide, wind speed and direction, relative humidity, and others.

C. Irrigation

The demand for water in agriculture sector is intensifying over time, because of the growth population, increasing family incomes, good nutrition and varied diet[49]. According to the United Nations World Water Development Report 2016, agriculture sector accounts for approximately 70% of water consumption all over the world. Without use of alternative and efficient approach, agriculture water consumption is predicted to rise by 20% by 2050. So, we need optimal irrigation systems based on information and communication technologies (ICT),

sensors, microcontroller, actuators etc. to minimize water consumption and maximize the crops production.

New irrigation systems utilize network sensors and actuators to measure and control soil moisture parameter[50]. The measured data transfer via IOT communications to the local or remote servers for processing and analysis. In many projects, researchers use several sensors at the different depth of soil. These sensors provide information about how much

water crops really need to save water by preventing extra irrigation. Note, the excess water in the soil lose by evaporation and in some cause can be harmful to the crops and soil[51]. In the Fig.7 a smart irrigation system is shown. The system is

TABLE IV. SMARTPHONE APPS IN AGRICULTURE

Apps	Descriptions	OS
Sirrus	Sirrus helps agronomists and farmers on farming decisions by making field data accessible and easy to collect. This App developed by SST software group. Other features included: determine farm boundaries using GPS or draw them using visualization tools, connecting to the agX Platform etc.	iPad
Manure Monitor	This application is designed to help farmer in managing records related to manure. Manure Monitor allows multiple users to associate with the same farm. The user can record rainfall, storage, animal mortality, manure transfer, waterline and equipment information.	Android
Agrivi	Agrivi mobile App provides a fast insight into farming activities and guides farmers to improve their crop production and increase fertility. This App benefit from most effective production processes for more than 60 crops.	Android, iPad, iPhone
TractorPal	This app act like an old notebook that can keep inventory and maintenance records agriculture machines and attachments such as cars, trucks, and others. TractorPal has two sides: the inventory and the maintenance. The inventory keeps track of inventory and the maintenance side track of your tractor, car maintenance.	Android, iPad, iPhone
MachineryGuide	With the MachineryGuide users can use their smartphone as a precision farming, tractor GPS system at very low cost for agricultural machinery. Main features are included: visual selection control for agriculture sprayer, seeder etc., 2D and 3D view, snapshot view on Google Maps, dataset visualization on Google Maps and so on.	Android
Agrian Mobile	This App is one of the top 20 agriculture mobile App by CropLife America. Agrian Mobile allows farmers and experts to immediately search useful information about the crop protection product. With the help of this App the user can view datasheet for more than 8,000 crop protection products.	Android
Ag Leader AgFiniti Mobile	This App is developed by Ag Leader Technology. AgFiniti make your data accessible everywhere via your iPad. As well as, the user can login to AgFiniti cloud to keep all of their data in seamlessly sync through all of your devices. Mapping with high-definition quality, accurate summaries, and the great capability to search specific points on the map in order to get more data.	iPad
Agri Precision	Agri Precision use in the practice of precision agriculture. This App has capabilities like a GPS and help users to collect samples in the field. Agri uses precision agriculture techniques for generating sampled and recommended maps. Point to Point navigation for sampling, Generation of glebe's border, Generation of sampling grid etc. are the key features of this App.	Android

based on sensor technology and able user control irrigation system remotely to make easier management irrigation of the crops. Before implementation of the smart irrigation system, the farm or the greenhouse should examine in order to recognize their special requirements. Different type of soil moisture sensors is used to measure relative humidity strategic places of the farm or greenhouse.

Another aspect of IOT in irrigation is microcontroller-based smart irrigation systems, which offer great advantages[52]. Many agricultural parameters such as soil moisture, humidity, and leaf wetness, are continually monitored and sensed data is transferred to the microcontroller. Then, the data is sent to a monitoring base station through wireless communications. The base station analyses the data together with the atmospheric condition and according to the results, irrigation will schedule by using actuators and relay which control the pump (see Fig. 8).

## V. CHALLENGES

The internet of things faces some significant challenges that deal with these challenges to realize its potential advantages. In this paper, we categorize these challenges into two groups: the IOT and IOT components associated challenges that included the IoT Standardization and Implementation Challenges, 6LowPan challenges, sensory challenges, and Security and privacy, 2) the precision agriculture associated challenge that included big data challenge.

### A. Challenges related to the IOT and IOT components

#### 1) IoT Standardization and Implementation Challenges

Standardization is an important step towards creating value and the market for a new concept. The integration of things into the internet leads to several challenges in the field of adaptability the current internet protocols and technologies with these things. In the recent years, there have been extensive researches to match the existing protocols and technologies to these things[53]. A wide range of heterogeneous devices are

participating in the IOT; if the heterogeneous devices use different standard and protocols, achieve high levels of interoperability is difficult. Therefore, IOT standards bodies such as IEEE, European Telecommunications Standards Institute (ETSI) etc. should focus on developing a technological standard to meet the standardization challenges.

Internet of things refers to the networks of things that able to sense, collect data and communicate with other things and computers. There are a lot of reasons that cause difficult the implementation of this concept such as a number of the IOT components and intrinsic characteristics of these components. For example, data collecting usually is done via sensors. Then, this data transmit to IoT gateways and cloud server for more processes and analysis. In this case, challenges related to the IOT sensors (power consumption, security, and interoperability) and challenges associated with network implementation in IOT (security, power consumption, increasing the number of IoT devices etc.) are serious[54]. Additionally, a large number of IOT systems use the TCP/IP protocols. However, the evidence show that the TCP/IP protocol stack is not appropriate for the IOT applications. So, many researchers have tried to solve this challenge by proposing corrected versions of the TCP/IP protocol [55].

### 2) 6LoWPAN

The 6LoWPAN is abbreviations for IPv6 over low power wireless personal area networks (LoWPANs)[56]. 6LoWPAN enable devices with the constrained resource to send data via the IPv6. Based on the characteristic of LoWPANs[57], the major challenges and problem IP over LoWPANs included: 1)IP connectivity, 2)topologies, 3)limited packet size, 4) service discovery, 5)security and, 6) Limited configuration and management. The rapid IOT devices growth underlines the need for a new version of the IP with the larger addressing space and in many cases the IoT devices make network autoconfiguration. IPv6 solve these problems. Different topology like mesh and star is needed to support within the 6LoWPAN. In the mesh, topologies must use multi-hub routing that this rise to the serious challenge; in an IoT

application intermediate device need to have more computational and energy resources. Regarding LoWPAN applications, small size packets is expected (127 Bytes). On the other hand, IPv6 determine a maximum transmission unit (MTU) of 1280 bytes. 6LoWPAN must have a fragmentation format in order to split IPv6 packets into several smaller packets and reassembled at the destination. Security in the IOT components like sensors and actuators when they are communicated via IP is an important subject. LoWPAN uses AES algorithm (Advanced Encryption Standard) that key length encryption is a 128 bit. However, there are not any details about the implementation of key change and key management in the 6LoWPAN.

### 3) IoT sensors

In the precision agriculture, different types of sensors installed throughout the greenhouses and fields that are organized in the wireless sensor networks (WSN). The WSNs have the sever limitation on power consumption, limited processing capability, and sensors with small memory [58]. These limitations pose challenges to the sensor based agricultural applications. For example, environmental and ecological monitoring and irrigation systems are major applications in the context of agriculture. A scalable WSN can improve the performance of a current sensor based applications by adding new sensors to the network to measure extra parameters. Some challenges associated with the sensors signal strength and selected area for implementation of the network. For example the presence of obstruction and humidity can reduce signal strength connectivity.

Usually, the sensors node power by the limited power sources (e.g. battery) that it represents the challenge in the lifetime of nodes, especially for agricultural applications that need long time lifetime. There are some solutions to saving power in the sensor based agricultural applications such as data mitigation methods [59-62], sleep/wake strategies[63], and radio transmission optimization[64,65].

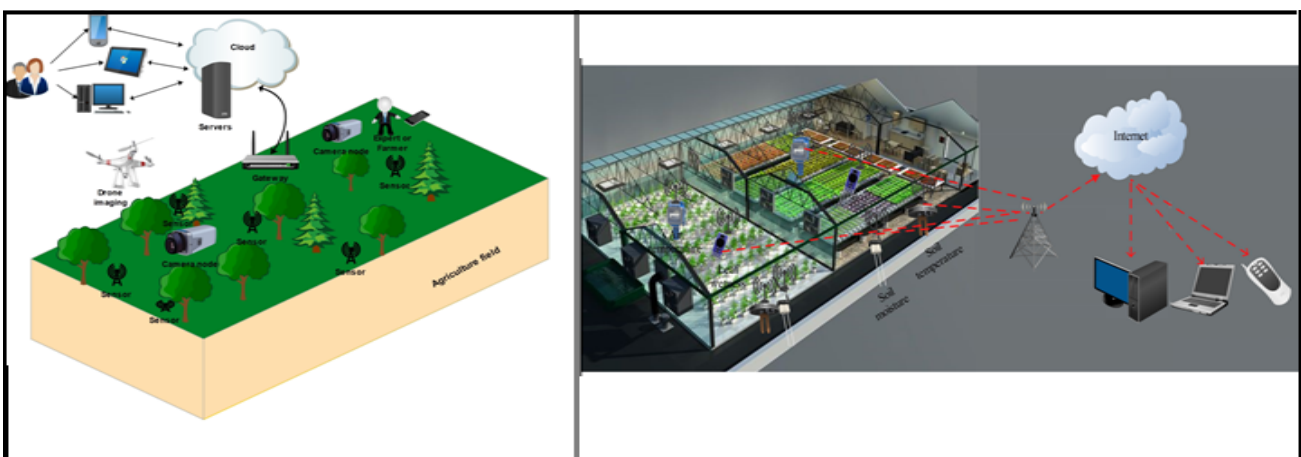

Figure 6. An overview of monitoring and control in agriculture



#### 4) Security and privacy

The sensors send collected data about the field and agricultural parameters over the network via different links. Reliable data transfer to the others networks and sensors node is one of the main goals in the WSNs. Simultaneously, with regards to the large covered areas in the agricultural applications and the WSNs limitations, employ an effective security technique is a crucial and challenging issue. Researchers have been proposed several network security schemas in the agricultural area [66-68]. Furthermore, security in routing protocols is another security challenge. Malicious users try to carry out attack on routing protocols that it can break down a network. So, extend the reliable and secure routing protocol for the WSN have been a hot research topic. On the other hand, as we said before, the WSNs have severe limitations that cause conventional routing protocols not to be used in WSNs. According to the [69], there are two major challenged associated with security algorithms in WSNs that included: 1) the security algorithms impose an overload of data on messages that must be decline as much as possible to increase the lifetime of the sensor node, 2) the sensor nodes have small memory size; indeed small memory size can lead to the small security key.

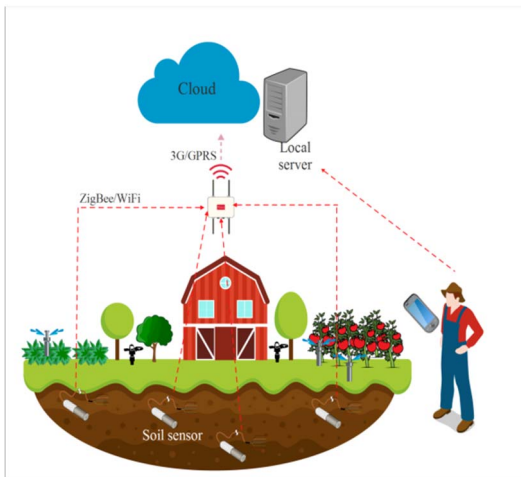

Figure 7. A modern irrigation system

Due to the outdoor applications of wireless sensor networks, the privacy is a big issue in the sensor networks. Generally, there are two privacy concerns in the field of the WSNs, data-oriented and context-oriented privacy. Data-oriented privacy handle security, preserving, and integrity of the collected data, which exchanged between different nodes in the network[70]. And context oriented privacy deals with contextual information (e.g. location and time) against the malicious person. A reliable data cryptographic algorithm is needed to satisfy data privacy and in general data, privacy can be put into two groups named 'data aggregation' and 'data query'. Also, 'spatial and temporal privacy' are a different type of context-oriented privacy in WSNs.

#### B. Challenges related to the precision agriculture

##### 1) Data challenges

Precision agriculture focuses on data and cyber-physical system (CPS) for management of the farm and increases productivity. Based on the literature, data usage in agriculture bring up some issues such as missing data, noisy data, heterogeneous data, spatiotemporal data, and big agricultural data. Agricultural data can be missing due to failure in equipment or node failure in the network, data post-processing, and pest/disease. Missing data cause biased estimates and reduce the performance of IOT application on agriculture by losing a significant number of captured events. Over time, a large number of studies have proposed various methods for imputation missing data such as multiple mean matching method[71], regression technique[72], kernel smoothing, universal kriging[73]. Machinery, power source, weather condition, human error, mislabeled data, and measurement error are the main source of missing data in agriculture. Data mining in agriculture is a new topic in the context of precision agriculture (PA) and data mining. Data mining techniques have many applications in PA that included assist crop protection[74], prediction irrigation[75], reducing the use of pesticides[76] and others. On the other hand, noisy and abnormal data are serious obstacles to the effective use of data mining techniques in PA. Therefore, dealing with noisy data by existing techniques [77-80] is crucial. Heterogeneous data is another challenge related to data, which result from the nature of big data. Agricultural data can collect from various sources such as sensors, drone, camera, and RFID tags. In fact, heterogeneously associated with big data, so we should use mechanisms to reducing the memory and time for data analysis.

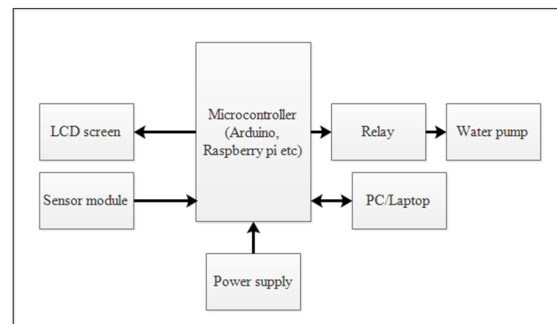

Figure 8. Block diagram of a smart irrigation system based on Microcontroller

#### VI. CONCLUSION

In the recent years, IOT has been grown rapidly and different numbers of IOT based applications have been developed in many domains especially in agriculture. This paper reported on the current state of the internet of things in the agriculture by studying major works of literature, research trend in IOT, examining popular hardware and cloud platforms, agriculture APPs, IOT application in agriculture, and existing challenges.

Integration IOT into agriculture can lead the quality improvement of crops and increasing productivity. In this way, microcontrollers and cloud computing are key actors in IOT based solutions. So, we surveyed six types of microcontrollers based on the different parameters. Moreover, according to the extensive activities major cloud companies in the cloud IOT and big data issues, this paper compared the main cloud IOT provides in the world to help researchers and stakeholders on the choice the best option.

The entire above are software and hardware technologies, which are almost essential for the IOT applications in agriculture. When it comes to agricultural IOT applications, we are expected IoT to increase crops production, improve quality of yields, optimize the irrigation, and decrease environmental degradation. All of these goals are potentially realizable through precision agriculture.

#### REFERENCES

- [1] Miorandi, D., Sicari, S., De Pellegrini, F., & Chlamtac, I. (2012). Internet of things: Vision, applications and research challenges. *Ad Hoc Networks*, 10(7), 1497-1516.
- [2] Srbinovska, M., Gavrovski, C., Dimcev, V., Krkoleva, A., & Borozan, V. (2015). Environmental parameters monitoring in precision agriculture using wireless sensor networks. *Journal of Cleaner Production*, 88, 297-307.
- [3] Alexandratos, N., & Bruinsma, J. (2012). World agriculture towards 2030/2050: the 2012 revision. ESA Working paper Rome, FAO.
- [4] Chen, X.-Y., & Jin, Z.-G. (2012). Research on key technology and applications for internet of things. *Physics Procedia*, 33, 561-566.
- [5] Qiuping, W., Shunbing, Z., & Chunquan, D. (2011). Study on key technologies of Internet of Things perceiving mine. *Procedia Engineering*, 26, 2326-2333.
- [6] Koshizuka, N., & Sakamura, K. (2010). Ubiquitous ID: standards for ubiquitous computing and the Internet of Things. *IEEE Pervasive Computing*, 9(4), 98-101.
- [7] Minerva, R., Biru, A., & Rotondi, D. (2015). Towards a definition of the Internet of Things (IoT). *IEEE Internet Initiative*(1).
- [8] Kushalnagar, N., Montenegro, G., & Schumacher, C. (2007). IPv6 over low-power wireless personal area networks (6LoWPANs): overview, assumptions, problem statement, and goals.
- [9] Khorov, E., Lyakhov, A., Krotov, A., & Guschin, A. (2015). A survey on IEEE 802.11 ah: An enabling networking technology for smart cities. *Computer Communications*, 58, 53-69.
- [10] Mesas-Carrascosa, F., Santano, D. V., Meroño, J., de la Orden, M. S., & García-Ferrer, A. (2015). Open source hardware to monitor environmental parameters in precision agriculture. *Biosystems Engineering*, 137, 73-83.
- [11] Sawashe, M. T. A., Mirshikari, M. A. A., Mulla, M. S. M., & Ghorpade, M. S. R. (2017). Water Pump Monitoring and Controlling Using Arduino. *ASIAN JOURNAL OF CONVERGENCE IN TECHNOLOGY*, 3(3).
- [12] Celen, I., Onler, E., & Kilic, E. Design of an autonomous agricultural robot to navigate between rows. In *2015 International Conference on Electrical, Automation and Mechanical Engineering*; Atlantis Press: Phuket, Thailand, 2015
- [13] Nuvvula, J., Adiraju, S., Mubin, S., Bano, S., & Valisetty, V. R. ENVIRONMENTAL SMART AGRICULTURE MONITORING SYSTEM USING INTERNET OF THINGS.
- [14] RM, K., Kumariyarasi, J., & Manisha, R. (2017). Optimization and Control of Hydroponics Agriculture Using IOT.
- [15] Salazar, R., Rangel, J. C., PINZÓN, C., & Rodríguez, A. (2013). Irrigation system through intelligent agents implemented with arduino technology. *ADCAIJ: Advances in Distributed Computing and Artificial Intelligence Journal*, 2(3), 29-36.
- [16] Shaout, A., Juzswik, K., Nguyen, K., Peurasaari, H., & Awad, S. An embedded system for agricultural monitoring of remote areas. In *Computer Engineering Conference (ICENCO), 2015 11th International, 2015* (pp. 58-67): IEEE
- [17] Rekha, P., Saranya, T., Preethi, P., Saraswathi, L., & Shobana, G. Smart AGRO Using ARDUINO and GSM.
- [18] Jiajin, Z., Lichang, C., Qingsong, D., Haidong, Z., & Yonghua, Z. A social networks integrated sensor platform for precision agriculture. In *Network Infrastructure and Digital Content (IC-NIDC), 2014 4th IEEE International Conference on, 2014* (pp. 131-136): IEEE
- [19] Zachariadis, S., & Kaskalis, T. H. (2012). An Embedded System for Smart Vineyard Agriculture.
- [20] Naik, P., Kumbi, A., Vishwanath Hiregoudar, C. N., Pavitra, H., Sushma, B., Sushmita, J., et al. (2017). Arduino Based Automatic Irrigation System Using IoT.
- [21] Sudhakar, M., & Swathi, V. (2016). Real Time Weather Data Acquisition and Monitoring From a Remote Location Using ARM-11 Processor and IoT. *IJITR*, 4(3), 2980-2984.
- [22] Sukhadeve, V., & Roy, S. (2016). Advance Agro Farm Design With Smart Farming, Irrigation and Rain Water Harvesting Using Internet of Things. *International Journal of Advanced Engineering and Management*, 1(1), 33-45.
- [23] Alahi, M. E. E., Li, X., Mukhopadhyay, S., & Burkitt, L. (2017). A Temperature Compensated Smart Nitrate-Sensor for Agricultural Industry. *IEEE Transactions on Industrial Electronics*.
- [24] 24. Koprda, S., Balogh, Z., Hrubý, D., & Turčám, M. Proposal of the irrigation system using low-cost Arduino system as part of a smart home. In *Intelligent Systems and Informatics (SISY), 2015 IEEE 13th International Symposium on, 2015* (pp. 229-233): IEEE
- [25] 25. Khan, S. Wireless Sensor Network based Water Well Management System for precision agriculture. In *Telecommunication Networks and Applications Conference (ITNAC), 2016 26th International, 2016* (pp. 44-46): IEEE
- [26] Chuang, J.-C. S., & Jiang, J.-A. (2013). A novel automatic ICT system for orchid greenhouse monitoring.
- [27] Bhong, V. S., & Pawar, B. Implementation of Farming Robot for Various Agricultural Applications.
- [28] Bachmann, F., Herbst, R., Gebbers, R., & Hafner, V. (2013). Micro UAV based georeferenced orthophoto generation in VIS+ NIR for precision agriculture. *Int. Arch. Photogramm. Remote Sens. Spat. Inf. Sci*, 11-16.
- [29] Shivaprasad, B., & Ravishankara, M. (2014). Design and implementation of seeding and fertilizing agriculture robot. *International Journal of Application or Innovation in Engineering & Management (IJAIEM)*, 3(6), 251-255.
- [30] Lakshmisudha, K., Hegde, S., Kale, N., & Iyer, S. (2016). Smart Precision Based Agriculture Using Sensors. *International Journal of Computer Applications*, 146(11), 36-38.
- [31] Agrawal, N., & Singhal, S. Smart drip irrigation system using raspberry pi and arduino. In *Computing, Communication & Automation (ICCCA), 2015 International Conference on, 2015* (pp. 928-932): IEEE
- [32] Ibrahim, M., Elgamri, A., Babiker, S., & Mohamed, A. Internet of things based smart environmental monitoring using the raspberry-pi computer. In *Digital Information Processing and Communications (ICDIPC), 2015 Fifth International Conference on, 2015* (pp. 159-164): IEEE
- [33] Sahu, C. K., & Behera, P. A low cost smart irrigation control system. In *Electronics and Communication Systems (ICECS), 2015 2nd International Conference on, 2015* (pp. 1146-1152): IEEE
- [34] Bapat, V., Kale, P., Shinde, V., Deshpande, N., & Shaligram, A. (2017). WSN application for crop protection to divert animal intrusions in the agricultural land. *Computers and Electronics in Agriculture*, 133, 88-96.
- [35] Patokar, A. M., & Gohokar, V. V. (2018). Precision Agriculture System Design Using Wireless Sensor Network. In *Information and Communication Technology* (pp. 169-177): Springer.

- [36] Kumar, P., Motia, S., & Reddy, S. Wireless Soil Multi-parameters Remote Monitoring and Alerting System. In National Conference on Product Design (NCPD 2016), 2016
- [37] Kumar, P., & Reddy, S. Design and development of M3SS: A Soil Sensor Node for precision agriculture. In Recent Advances and Innovations in Engineering (ICRAIE), 2016 International Conference on, 2016 (pp. 1-10): IEEE
- [38] Wang, N., Zhang, N., & Wang, M. (2006). Wireless sensors in agriculture and food industry—Recent development and future perspective. *Computers and electronics in agriculture*, 50(1), 1-14.
- [39] Hasan, M., Hossain, E., & Niyato, D. (2013). Random access for machine-to-machine communication in LTE-advanced networks: issues and approaches. *IEEE communications Magazine*, 51(6), 86-93.
- [40] Patel, H., & Patel, D. (2016). Survey of android apps for agriculture sector. *International Journal of Information Sciences and Techniques*, 6(1-2), 61-67.
- [41] Khattab, A., Abdelgawad, A., & Yelmarthi, K. Design and implementation of a cloud-based IoT scheme for precision agriculture. In *Microelectronics (ICM), 2016 28th International Conference on*, 2016 (pp. 201-204): IEEE
- [42] Popović, T., Latinović, N., Pešić, A., Zečević, Ž., Krstajić, B., & Djukanović, S. (2017). Architecting an IoT-enabled platform for precision agriculture and ecological monitoring: A case study. *Computers and electronics in agriculture*, 140, 255-265.
- [43] Zhou, Y., Yang, X., Guo, X., Zhou, M., & Wang, L. A design of greenhouse monitoring & control system based on ZigBee wireless sensor network. In *Wireless Communications, Networking and Mobile Computing, 2007. WiCom 2007. International Conference on*, 2007 (pp. 2563-2567): IEEE
- [44] Zaks, D. P. M., & Kucharik, C. J. (2011). Data and monitoring needs for a more ecological agriculture. *Environmental Research Letters*, 6(1), 014017.
- [45] Kim, N.-S., Lee, K., & Ryu, J.-H. Study on IoT based wild vegetation community ecological monitoring system. In *Ubiquitous and Future Networks (ICUFN), 2015 Seventh International Conference on*, 2015 (pp. 311-316): IEEE
- [46] Spellerberg, I. F. (2005). *Monitoring ecological change*: Cambridge University Press.
- [47] Su, X., Shao, G., Vause, J., & Tang, L. (2013). An integrated system for urban environmental monitoring and management based on the Environmental Internet of Things. *International Journal of Sustainable Development & World Ecology*, 20(3), 205-209.
- [48] Roman, R., Alcaraz, C., & Lopez, J. (2007). A survey of cryptographic primitives and implementations for hardware-constrained sensor network nodes. *Mobile Networks and Applications*, 12(4), 231-244.
- [49] De Fraiture, C., & Wichelns, D. (2010). Satisfying future water demands for agriculture. *Agricultural water management*, 97(4), 502-511.
- [50] de Lima, G. H., e Silva, L. C., & Neto, P. F. WSN as a Tool for Supporting Agriculture in the Precision Irrigation. In *Networking and Services (ICNS), 2010 Sixth International Conference on*, 2010 (pp. 137-142): IEEE
- [51] Sivakumar, B., Gunasekaran, P., Selvaprabhu, T., Kumaran, P., & Anandan, D. (2012). The Application of Wireless Sensor Network in the Irrigation Area Automatic System. *Int. J. Comp. Tech. Appl*, 3, 67-70.
- [52] Gunturi, V. N. R. (2013). Micro controller based automatic plant irrigation system. *International Journal of Advancements in Research & Technology*, 2(4), 194-198.
- [53] Sfar, A. R., Natalizio, E., Challal, Y., & Chtourou, Z. (2017). A Roadmap for Security Challenges in Internet of Things. *Digital Communications and Networks*.
- [54] *iot implementation challenges* (2015). <https://www.linkedin.com/pulse/iot-implementation-challenges-ahmed-banafa>.
- [55] Palattella, M. R., Accettura, N., Vilajosana, X., Watteyne, T., Grieco, L. A., Boggia, G., et al. (2013). Standardized Protocol Stack for the Internet of (Important) Things. *IEEE Communications Surveys & Tutorials*, 15(3), 1389-1406, doi:10.1109/SURV.2012.111412.00158.
- [56] Zach Shelby, C. B. (2011). *6LoWPAN: The Wireless Embedded Internet* (Vol. 43): Wiley.
- [57] <https://tools.ietf.org/html/draft-ietf-6lowpan-problem-08#page-3> (2007). 6LoWPAN: Overview, Assumptions, Problem Statement and Goals.
- [58] Akyildiz, I. F., Su, W., Sankarasubramaniam, Y., & Cayirci, E. (2002). A survey on sensor networks. *IEEE communications Magazine*, 40(8), 102-114.
- [59] Azaza, M., Tanougast, C., Fabrizio, E., & Mami, A. (2016). Smart greenhouse fuzzy logic based control system enhanced with wireless data monitoring. *ISA transactions*, 61, 297-307.
- [60] Musaaazi, K. P., Bulega, T., & Lubega, S. M. Energy Efficient Data Caching in Wireless Sensor Networks: A Case of Precision Agriculture. In *International Conference on e-Infrastructure and e-Services for Developing Countries*, 2014 (pp. 154-163): Springer
- [61] Zheng, L., Li, M., Wu, C., Ye, H., Ji, R., Deng, X., et al. (2011). Development of a smart mobile farming service system. *Mathematical and computer modelling*, 54(3), 1194-1203.
- [62] Ruirui, Z., Liping, C., Jianhua, G., Zhijun, M., & Gang, X. (2010). An energy-efficient wireless sensor network used for farmland soil moisture monitoring.
- [63] Shi, G., Nan, G., Kou, J., & Rong, R. (2011). Comprehensive Review of Sleep/Wake Scheduling in Wireless Sensor Networks. *High Performance Networking, Computing, and Communication Systems*, 492-499.
- [64] Sahota, H., Kumar, R., Kamal, A., & Huang, J. An energy-efficient wireless sensor network for precision agriculture. In *Computers and Communications (ISCC), 2010 IEEE Symposium on*, 2010 (pp. 347-350): IEEE
- [65] Kamarudin, L., Ahmad, R., Ndzi, D., Zakaria, A., Ong, B., Kamarudin, K., et al. Modeling and Simulation of WSNs for Agriculture Applications Using Dynamic Transmit Power Control Algorithm. In *Intelligent Systems, Modelling and Simulation (ISMS), 2012 Third International Conference on*, 2012 (pp. 616-621): IEEE
- [66] Panda, M. Data security in wireless sensor networks via AES algorithm. In *Intelligent Systems and Control (ISCO), 2015 IEEE 9th International Conference on*, 2015 (pp. 1-5): IEEE
- [67] Grgic, K., Zagar, D., & Krizanovic, V. Security in IPv6-based wireless sensor network—Precision agriculture example. In *Telecommunications (ConTEL), 2013 12th International Conference on*, 2013 (pp. 79-86): IEEE
- [68] Baranwal, T., & Pateriya, P. K. Development of IoT based smart security and monitoring devices for agriculture. In *Cloud System and Big Data Engineering (Confluence), 2016 6th International Conference*, 2016 (pp. 597-602): IEEE
- [69] Rizk, R., & Alkady, Y. (2015). Two-phase hybrid cryptography algorithm for wireless sensor networks. *Journal of Electrical Systems and Information Technology*, 2(3), 296-313, doi:<https://doi.org/10.1016/j.jesit.2015.11.005>.
- [70] Roy, P. K., Singh, J. P., Kumar, P., & Singh, M. (2015). Source location privacy using fake source and phantom routing (FSAPR) technique in wireless sensor networks. *Procedia Computer Science*, 57, 936-941.
- [71] Jinubala, L. (2016). Analysis of Missing Data and Imputation on Agriculture Data With Predictive Mean Matching Method. *International Journal of Science and Applied Information Technology (IJSAIT)*, 5(1), 5.
- [72] Fetter, M. Mass imputation of agricultural economic data missing by design: a simulation study of two regression based techniques. In *Federal Conference on Survey Methodology*, 2001
- [73] Lokupitiya, R. S., Lokupitiya, E., & Paustian, K. (2006). Comparison of missing value imputation methods for crop yield data. *Environmetrics*, 17(4), 339-349.
- [74] Hill, M. G., Connolly, P. G., Reutemann, P., & Fletcher, D. (2014). The use of data mining to assist crop protection decisions on kiwifruit in New Zealand. *Computers and electronics in agriculture*, 108(Supplement C), 250-257, doi:<https://doi.org/10.1016/j.compag.2014.08.011>.
- [75] Khan, M. A., Islam, M. Z., & Hafeez, M. Evaluating the performance of several data mining methods for predicting irrigation water requirement.

- In Proceedings of the Tenth Australasian Data Mining Conference-Volume 134, 2012 (pp. 199-207): Australian Computer Society, Inc.
- [76] Abdullah, A., Brobst, S., Pervaiz, I., Umer, M., & Nisar, A. Learning dynamics of pesticide abuse through data mining. In Proceedings of the second workshop on Australasian information security, Data Mining and Web Intelligence, and Software Internationalisation-Volume 32, 2004 (pp. 151-156): Australian Computer Society, Inc.
- [77] Craven, P., & Wahba, G. (1978). Smoothing noisy data with spline functions. *Numerische mathematik*, 31(4), 377-403.
- [78] Zhuang, Y., Chen, L., Wang, X. S., & Lian, J. A weighted moving average-based approach for cleaning sensor data. In Distributed Computing Systems, 2007. ICDCS'07. 27th International Conference on, 2007 (pp. 38-38): IEEE
- [79] Jeffery, S. R., Alonso, G., Franklin, M. J., Hong, W., & Widom, J. A pipelined framework for online cleaning of sensor data streams. In Data Engineering, 2006. ICDE'06. Proceedings of the 22nd International Conference on, 2006 (pp. 140-140): IEEE
- [80] Elnahrawy, E., & Nath, B. Online data cleaning in wireless sensor networks. In Proceedings of the 1st International conference on Embedded networked sensor systems, 2003 (pp. 294-295): ACM